

# High-voltage high-frequency Marx-bank type pulse generator using integrated power semiconductor half-bridges

L.M. Redondo<sup>1,2</sup>, J. Fernando Silva<sup>1,3,4</sup>, P. Tavares<sup>5</sup>, Elmano Margato<sup>1,4</sup>

<sup>1</sup>Instituto Superior de Engenharia de Lisboa  
Rua Conselheiro Emídio Navarro 1, 1950-062 Lisboa, Portugal

<sup>2</sup>Centro de Física Nuclear da Universidade de Lisboa  
Avenida Prof. Gama Pinto 2, 1649-003 Lisboa, Portugal

<sup>3</sup>Instituto Superior Técnico  
Av. Rovisco Pais 1, 1049-001 Lisboa, Portugal

<sup>4</sup>Centro de Automática da Universidade Técnica de Lisboa  
Av. Rovisco Pais 1, 1049-001 Lisboa, Portugal

<sup>5</sup>Indústrias Lever Portuguesa S.A.  
R. Cidade de Goa, 22-24, 2689-502 Sacavém, Portugal

E-Mail: [lmredondo@deea.isel.ipl.pt](mailto:lmredondo@deea.isel.ipl.pt), [fernandos@alfa.ist.utl.pt](mailto:fernandos@alfa.ist.utl.pt), [Pedro.Tavares@unilever.com](mailto:Pedro.Tavares@unilever.com),  
[emargato@deea.isel.ipl.pt](mailto:emargato@deea.isel.ipl.pt)

## Acknowledgements

The authors would like to thank Instituto Superior Técnico, Instituto Superior de Engenharia de Lisboa and Fundação da Ciência e da Tecnologia for supporting this work.

## Keywords

Energy storage, High frequency power converter, High power discrete device, Power supply.

## Abstract

This paper discusses the operation of an all silicon-based solution for the conventional Marx generator circuit, which has been developed for high-frequency (kHz), high-voltage (kV) applications needing rectangular pulses. The conventional Marx generator, for high-voltage pulsed applications, uses passive power components (inductors or resistors), to supply the energy storage capacitors. This solution has the disadvantages of cost, size, power losses and limited frequency operation. In the proposed circuit, the bulky passive power elements are replaced by power semiconductor switches, increasing the performance of the classical circuit, strongly reducing costs, losses and increasing the pulse repetition frequency. Also, the proposed topology enables the use of typical half-bridge semiconductor structures, and ensures that the maximum voltage blocked by the semiconductors equals the power supply voltage (i.e. the voltage of each capacitor), even with mismatches in the synchronized switching, and in fault conditions. A laboratory prototype with five stages, 5 kW peak power, of the proposed silicon-based Marx generator circuit, was

constructed using 1200 V IGBTs and diodes, operating with 1000 V d-c input voltage and 10 kHz frequency, giving 5 kV / 1 A pulses, with 10  $\mu$ s width and 50 ns rise time.

## Introduction

High-voltage pulsed power is now a very important research field and an expanding industrial technology with major worldwide economical impact. From the earlier high energy physics, particle accelerators and weapons applications, it has grown up to the commercial semiconductor and metal treatment process applications. New process for food sterilization, waste treatment, pollution control, medical diagnostics and treatment are also being developed, which require high-voltage pulses, needing efficient and suitable pulsed power supplies, based on power semiconductor switches and on new topologies brought from power electronics [1].

One attractive application is plasma immersion ion implantation (PIII), a versatile, relatively new, surface treatment technique for implanting ions. Where, the sample is immersed in a plasma chamber, and short, almost rectangular, negative high-voltage pulses are applied to it, resulting in the acceleration of the plasma ions to the sample surface and subsequent implantation of the sample [2].

The most widely used technique to generate high voltages, combines a high voltage power supply with semiconductor switches, either in series or resonant circuit associations to overcome the high voltage limitations of semiconductor devices. The use of step-up transformers, to further increase the output voltage pulses, is limited due to the existence of the transformer parasitic elements that worsens the pulse shape [3].

Another widely used method for generating high-voltage pulses is the Marx generator circuit [4], as shown in Fig. 1, charging capacitors ( $C_i$ ) in parallel and discharging them in series into the load (through a number of switches,  $S_i$ ), where the subscript  $i \in \{1, 2, \dots, n-1, n\}$ . The Marx generator requires only a relatively low-voltage power supply,  $V_{dc}$ , for charging and does not require pulse transformers to achieve the desired high-voltage.

The concept shown in Fig. 1 has been used intensively through the years, changing the switch technology, from spark gaps to vacuum or gas tubes and nowadays to solid-state semiconductors, and alternating resistive charging systems with inductive ones,  $Z_i$ . These technological upgrades increased the life-time of the circuit and the pulse repetition frequency, meaning an improved performance [5 - 9].

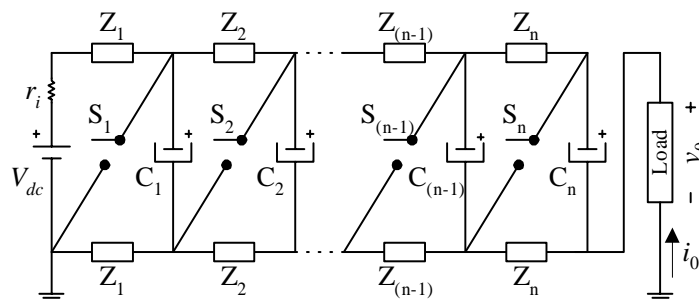

Fig. 1. Basic topology of the Marx generator circuit, with  $n$  stages, for negative output pulses to the load.

However, the use of bulky passive elements (resistors or inductors,  $Z_i$ ), as shown in Fig. 1, for charging the energy storing capacitors,  $C_i$ , and to limit the self-discharging of the capacitors, during the series operation, contributes to the low yield and efficiency of the circuit, limiting the pulse frequency, due to the long charging time constants, and degrading the generation of almost rectangular pulses.

Therefore, in the circuit here proposed, Fig. 2, to increase the performance of the classic Marx-bank generator topology, Fig. 1, no charging resistors or inductors are used. Instead, an all-silicon-based solution is obtained. Voltage increase is achieved by charging capacitors in parallel, through power semiconductor switches (IGBTs and diodes), and then discharging them in series by opening the charging switches, and closing the discharging ones. The circuit topology and operation mode block any self-discharging capacitor path. Due the power semiconductor topology used, almost rectangular high-frequency pulses can be obtained. Also, the proposed topology enables the use of typical half-bridge semiconductor structures, while ensuring that the maximum voltage blocked by the IGBTs is the voltage of each capacitor (i.e. the power supply voltage), even when the switching is not well synchronized, and even in fault conditions.

A laboratory prototype with five stages, 5 kW peak, of this silicon-based Marx generator circuit, was constructed using 1200 V IGBTs and diodes, operating with 1000 V d-c input voltage and 10 kHz repetition frequency. First experimental results show almost rectangular pulses with 5 kV / 1 A, near 50ns rise time and 10  $\mu$ s width, into a resistive load.

## Circuit Topology

Due to the intensive used of solid-state switches to charge and discharge the energy storing capacitors stages, the circuit will be named here as “All-Electronic Marx Generator” (AEMG).

The basic topology of the AEMG, with  $n$  stages, able to deliver negative high-voltage output pulses to a load, is presented in Fig. 2. Each stage of the AEMG consists of a energy storing capacitor  $C_i$ , a diode  $D_{ci}$  and two IGBTs ( $T_{ci}$  and  $T_{di}$ ), where the subscript  $i \in \{1, 2, \dots, n-1, n\}$ . Output positive pulses are simply obtained by inverting the polarity of all semiconductors as well as changing  $D_{ci}$  with  $T_{ci}$ .

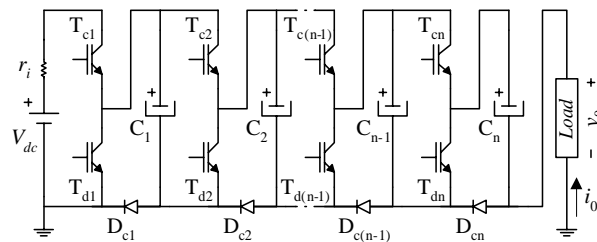

Fig. 2. Basic topology of the AEMG circuit, with  $n$  stages, for negative output pulses to the load.

The AEMG operation in Fig. 2 can be understood, considering only two different operating modes. In the first one, switches  $T_{ci}$  and  $T_{di}$  are, respectively, on and off. During this period, capacitors  $C_i$  are charged

from the dc power supply,  $V_{dc}$ , through  $T_{ci}$  and  $D_{ci}$ , as shown in Fig. 3, with current limited by the internal resistance of the elements, resulting in a small time constant that enables kHz operation. The on state of  $D_{ci}$  ensures that, during this period, the voltage,  $v_0$ , applied to the load is approximately zero, as shown in Fig. 5, for a resistive load.

Due to the parallel charging topology of the capacitors during this period, the charge currents are larger in the first stages. During starting on, the voltage  $V_{dc}$  is slowly increased to limit the charging current on the semiconductors  $T_{ci}$  and  $D_{ci}$ .

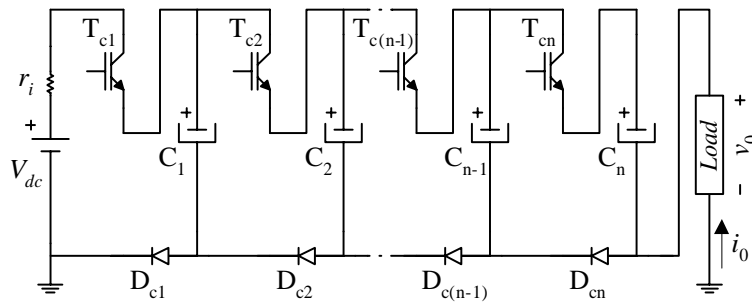

Fig. 3. Capacitors charging operation mode of the EMG in Fig. 2.

In the second operating mode, switches  $T_{ci}$  and  $T_{di}$  are, respectively, off and on. During this period, capacitors  $C_i$  are connected in series and the voltage applied to the load is, approximately,

$$v_0 = -nV_{dc} \quad (1)$$

considering that all capacitors are charged with  $V_{dc}$ , as shown in Fig. 4. However, this holds: *i*) on the characteristics of the components; *ii*) on the operating frequency; *iii*) on the capacitors charge time,  $t_c$ , being much longer than discharge time,  $t_d$ , meaning that  $T_{ci}$  and  $T_{di}$  operate, respectively, with a long ( $\delta_c = t_c/T$ ) and short ( $\delta_d = t_d/T$ ) switching duty cycle, as shown in Fig. 5. The off-state of  $D_{ci}$  ensures, during this period, that capacitors are not short-circuited by  $T_{di}$  switches.

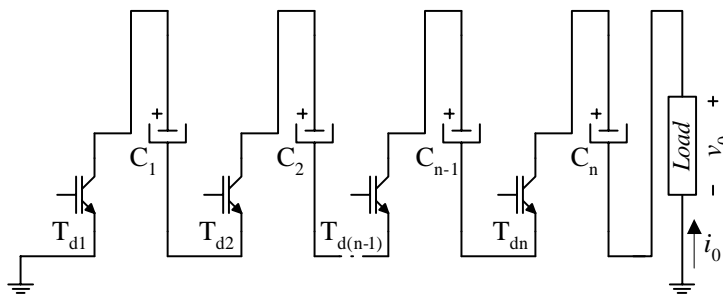

Fig. 4. Pulse operation mode of the AEMG in Fig. 2.

It is important that, during the pulse, the voltage drop, due to the discharge of the energy storing capacitors, is only a few percent of each capacitor voltage. To guarantee this, the energy stored in the capacitors,

$$E_{cap} = \frac{n}{2} C_i v_c^2 \quad (2)$$

where  $v_c$  is the voltage in the  $n$  capacitors, must be nearly 100 times greater than the energy delivered by each voltage pulse, to the load [2],

$$E_{pulse} = nV_{dc} i_0 t_d \quad (3)$$

where  $t_d$  is the on state period of  $T_{di}$  and  $i_0$  is the pulse current,

$$i_0 = nV_{dc} / Z_{load} \quad (4)$$

considering a resistive load and all capacitor charged with  $V_{dc}$ , as shown in Fig. 5.

For the above conditions, the plateau of the pulse voltage decreases exponentially, during the duration of the pulse, described by

$$v_0 = nV_{dc} e^{(-t/C_{eq}R_{eq})} \quad (5)$$

where  $C_{eq}$  is the capacitance equivalent to the series of  $C_i$ , and  $R_{eq}$  represents the equivalent series resistance of the circuit during this period, which is normally relatively low.

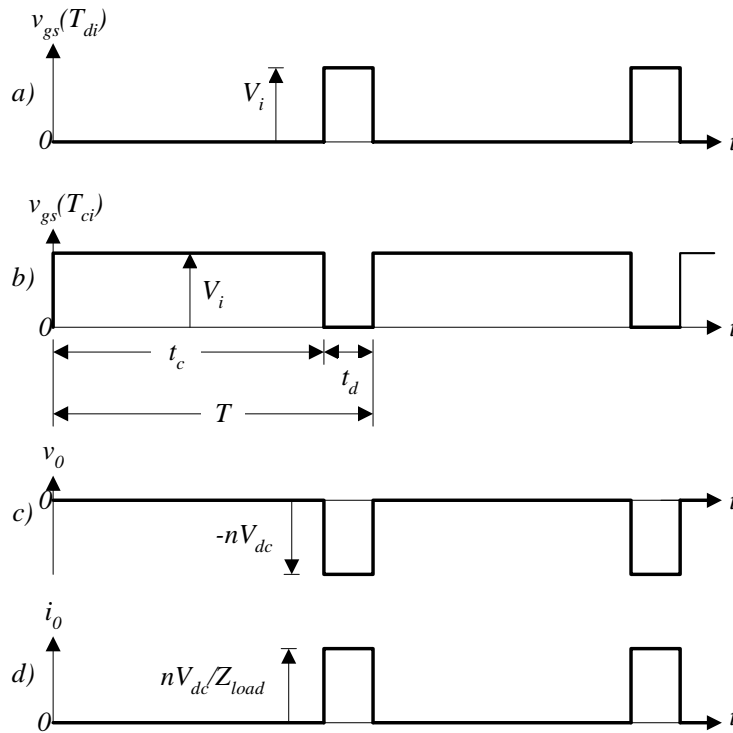

Fig. 5. Theoretical wave forms for the operation of the AEMG of Fig. 2, considering a resistive load: a) Drive signal of semiconductors  $T_{di}$ ; b) Drive signal of semiconductors  $T_{ci}$ ; c) load voltage,  $v_0$ ; d) load current,  $i_0$ .

The topology of the AEMG, in Fig. 2, guarantees that, if problems with the switching synchronization occur or in faulty conditions, the maximum voltage that each semiconductor holds is  $V_{dc}$  (maximum charge voltage of capacitors  $C_i$ ). As an example, if switch  $T_{dn}$  switches to on-state somewhat later than the remaining  $T_{di}$  switches, diode  $D_n$  stays on during this period, maintaining the voltage at the terminals of  $T_{dn}$  equal to the capacitor  $C_n$  voltage. During this condition the load voltage is, roughly,

$$v_0 = -(n-1)V_{dc} \quad (6)$$

In addition to the above described advantages, the switching sequence and switch configuration, seen in Fig. 2, enables the use of typical half-bridge semiconductor structures currently integrated in modular packages, which is advantageous to build the circuit and to drive the semiconductors.

It is important to avoid cross conduction between  $T_{di}$  and  $T_{ci}$  switches, due to the circuit topology in Fig. 2. Therefore, a dead time is introduced between the switching input control signals, so that the turn-on control input to  $T_{di}$  IGBTs is delayed with respect to the turn-off control input of  $T_{ci}$  IGBTs, and vice-versa.

Additionally, due to the fact that, there are two drive signals for the solid-state switches, in the circuit of Fig. 2,  $v_{gs(Tdi)}$  and  $v_{gs(Tci)}$ , respectively, to  $T_{di}$  and  $T_{ci}$ , which must be driven synchronously, the complexity of the driving circuit is increased, compared to the circuit in Fig. 1. Moreover, all the semiconductor switches are at different potentials, requiring gate circuits with galvanic isolation (optic fibres are used to transmit the gate signals).

## Experimental Results

A laboratory prototype of the AEMG circuit of Fig. 2, with five stages,  $4.5 \mu\text{F}$  capacitors, was built using 1200 V IGBTs and diodes, operating with  $V_{dc}=1000 \text{ V}$ , 10% duty cycle and 10 kHz repetition rate. Fig. 6 shows the pulse pulse,  $v_0$ , and pulse current,  $i_0$ , for a resistive load.

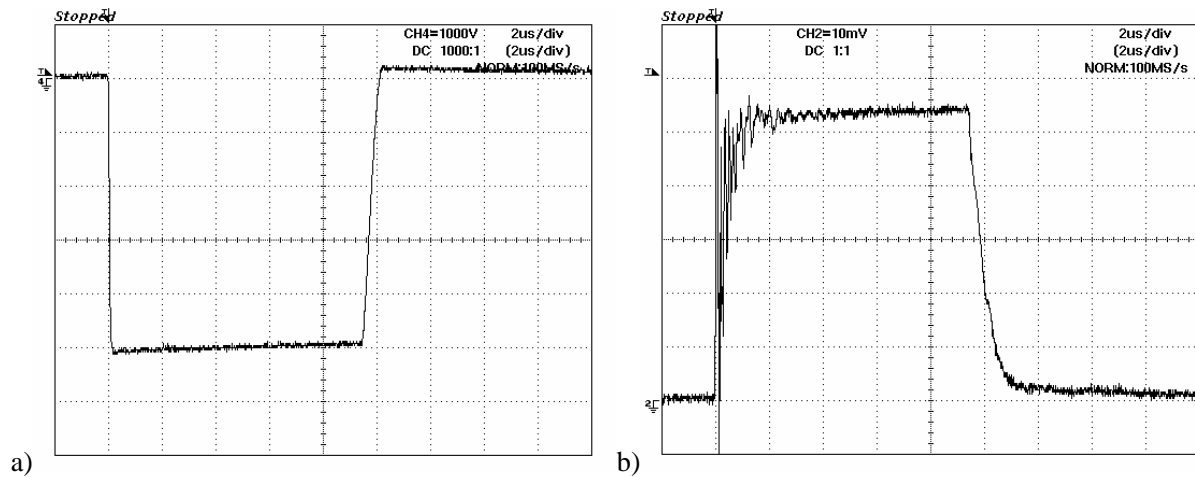

Fig. 6. Experimental results for the AEMG of Fig.2, horizontal scale 2 ( $\mu\text{s}/\text{div}$ ): a) Voltage pulse,  $v_0$ , 1000 (V/div); b) Current,  $i_0$ , 2 (A/div).

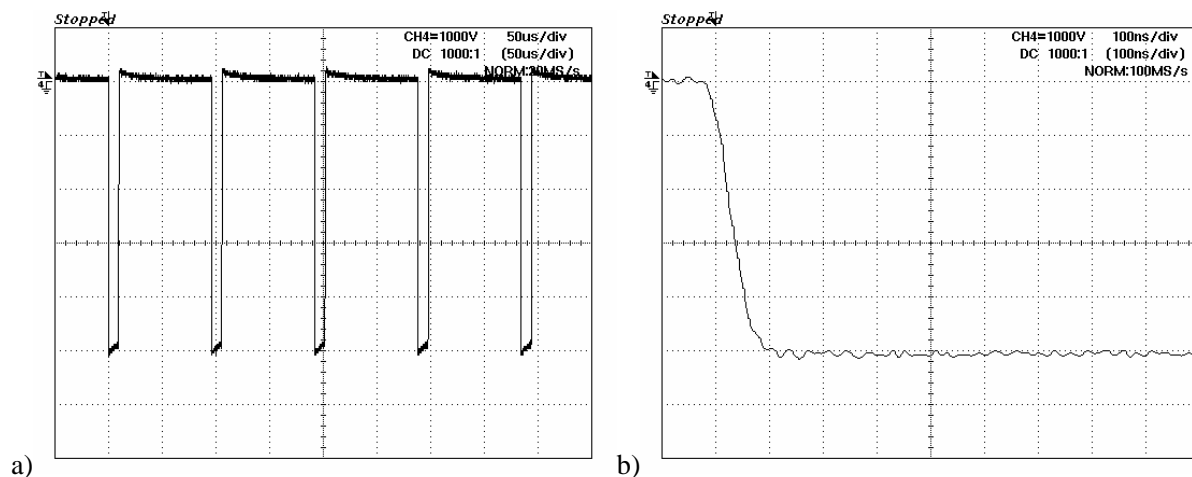

Fig. 7. Experimental results for AEMG of Fig. 2, Voltage pulse,  $v_0$ , 1000 (V/div), horizontal scale: a) 50 ( $\mu\text{s}/\text{div}$ ), b) 100 (ns/div)

The voltage pulse, in Fig. 7 a), exhibit an almost rectangular shape with - 5 kV amplitude and 10  $\mu\text{s}$  width, giving 1 A, into a resistive load, Fig. 7 b). The 10 kHz pulse frequency is observed in Fig. 8 a), and the 50 ns pulse rise time is shown in Fig. 8 b).

## Conclusion

This paper proposed a new all-silicon-based Marx-bank circuit topology for high-voltage, high frequency pulse generator circuit for rectangular pulsed applications. In this new circuit, the bulky passive power elements, used to charge the energy storing capacitors, were replaced with power semiconductor switches, increasing the performance of the classical circuit, strongly reducing cost, losses and increasing the pulse repetition frequency. Also, the proposed topology enables the use of typical half-bridge semiconductor structures, and ensures that the maximum voltage blocked by the semiconductors is the power supply voltage, even with mismatches in the synchronized switching, and in fault conditions.

A laboratory prototype with five stages, 5 kW peak power, of this silicon-based Marx generator circuit, was constructed using 1200 V IGBTs and diodes, operating with 1000 V d-c input voltage and 10 kHz frequency, giving 5 kV / 1 A pulses, with 10  $\mu\text{s}$  width and 50 ns rise time. Using state-of-the-art kV IGBTs and diodes, high voltage pulses reaching dozens of kV can be obtained using the AEMG concept.

## References

- [1]. Cook, E. G.: "Review of Solid-State Modulators", Presented at the XX International Linac Conference, 21-25 Monterey, August 2000. [3]. Mark R. Brown. Using Netscape 4, Simon & Schuster MacMillan, Indianapolis, Indiana 46290, USA, 1997.
- [2]. Conrad, J. R.; Radtke, J. L.; Dodd, R. A.; Worzala, Frank J.; Tran, Ngoc C.: "Plasma source ion-implantation technique for surface modification of materials", J. Appl. Phys., Vol. 62 (11), pp. 4591- 4596, 1 December 1987.
- [3].Goebel, D. M.; "Pulse Technology", Chapter 8 de "Handbook of Plasma Immersion Ion Implantation & Deposition", Editor Anders, André, 1<sup>st</sup> edition, John Wiley & Sons, New York, 2000, p. 760, ISBN 0-471-24698-0.
- [4]. Willis, W. L.: "Pulse-Voltage Circuits", Chapter 3 de "High Power electronics", Editor Dollinger, R. E.; Sarjeant, W. James, Tab Books Inc., 1<sup>st</sup> Edition, 1989, ISBN 0-8306-9094-8.

- [5]. Ghasemi, Z.; Macgregor, S.; Anderson, J.; Lamont, Y.: "Development of an integrated solid-state generator for light inactivation of food-related pathogenic bacteria", *Meas. Sci. Technology*, Vol. 14, pp. N26-N32, 2003.
- [6]. O'Loughlin, J.; Lehr, J.; Loree, D.: "High repetition rate charging a Marx type generator", *Pulse Power Plasma Science, IEEE Conference, Digest of Technical Papers*, Vol. 1, pp. 242-245, June 2001.
- [7]. Okamura, K.; Kuroda, S.; Maeyama, M.: "Development of the high repetitive impulse voltage generator using semiconductor switches", *12<sup>th</sup> Pulsed Power Conference, Digest Of technical Papers*, Vol. 2, pp. 27-30, 1999.
- [8]. Rai, V.N.; Shukla, M.; Khardekar, R.K.: "A transistorized Marx Bank circuit providing sub-nanosecond high-voltage pulses", *Meas. Sci. Technology*, Vol. 5, pp. 447-449, 1994.
- [9]. Vardigans, S.V.G.; Cogan, D.: "A bipolar pulse tester for semiconductor devices", *J. Phys. E: Sci. Instrum.*, Vol. 19, pp. 1016-1019, 1986.