

Innovative Measurement Electronics



PT Ltd.

RD1, RD2
Remote Display
User Manual

Rev. 2.0

Copyright

All Rights Reserved. No part of this document may be copied, reproduced, republished, uploaded, posted, transmitted, distributed, stored in or introduced into a retrieval system in any form, or by any means (electronic, mechanical, photocopying, recording or otherwise) whatsoever without prior written permission of PT Ltd.

Disclaimer

PT Ltd reserves the right to make changes to the products contained in this manual in order to improve design, performance or reliability.

The information in this manual is believed to be accurate in all respects at the time of publication, but is subject to change without notice. PT Ltd assumes no responsibility for any errors or omissions and disclaims responsibility for any consequences resulting from the use of the information provided herein.

SPECIAL NOTE

Trade Use

This manual may occasionally make reference to Trade Use settings. Some individual settings may not be legal for trade use. Please check regulations with the appropriate Weights and Measures Authority.

Table of Contents

1.	INTRODUCTION	2
1.1.	Overview	2
1.2.	Document Scope	2
2.	SPECIFICATIONS.....	3
3.	DISPLAY	4
4.	INSTALLATION.....	5
4.1.	Overview	5
4.2.	Installation Preparation	5
4.3.	Dipswitches.....	6
4.4.	Unit Addressing	7
4.5.	Protocol Grouping.....	7
4.6.	Lock Communication Settings.....	8
4.7.	Decimal Point	8
4.7.1.	LED Unit.....	8
4.7.2.	Electromechanical Unit.....	8
4.8.	Serial Connection	10
4.8.1.	Baud Rate and Parity.....	10
4.8.2.	Earthing Requirements for Cable Shields	11
4.8.3.	Powering Indicator from Remote Display (Pins 8 and 9)	11
4.8.4.	Dim LED Display (Pins 10 and 11).....	11
4.8.5.	RS232 Receive Only	11
4.8.6.	RS485 Receive Only	12
4.8.7.	20mA Current Loop Receive Only	12
4.9.	Power Connection.....	13
4.10.	Mounting.....	15
4.10.1.	Clip Attachment.....	15
4.10.2.	Wall Mounting	15
4.11.	Weather Hood	16
4.12.	Mounting Options.....	16
5.	PROTOCOL GROUP 0	17
5.1.	Overview	17
5.2.	Protocol 1	17
5.3.	Protocol 2	18
5.4.	Protocol 3	19
5.5.	Protocol 4	20
5.6.	Protocol 5	21
5.7.	Protocol 6	22
5.8.	Protocol 7	23
5.9.	Protocol 8	24
5.10.	Protocol 9	25
5.11.	Protocol 10	26
5.12.	Protocol 11	27
5.13.	Protocol 12	28
5.14.	Protocol 13	29
5.15.	Protocol 14	30
5.16.	Protocol 15	31
5.17.	Protocol 16	32
5.18.	Protocol 17	33
5.19.	Protocol 18	34
5.20.	Protocol 19	35
5.21.	Protocol 20	36
5.22.	Protocol 21	37
5.23.	Protocol 22	38
6.	PROTOCOL GROUP 1 – TEXT ONLY.....	39
7.	ERROR MESSAGES	40
7.1.	Weighing Errors.....	40

1. Introduction

1.1. Overview

These remote displays are capable of displaying up to 7 alpha/numeric digits in Electro-mechanical (E/M) or up to 7 semi-alpha/numeric digits in LED format. An annunciator board is available with three status annunciations (centre of zero, net and motion). The displays are available in a variety of configurations: 4 digit, 5 digit, 5 digit + annunciator, 6 digit + annunciator and 7 digit.

The serial interface will support RS232, RS485 and 20mA Current Loop as standard. Facilities for automatic selection of the data source and baud rate are also standard.

These remote displays are capable of interpreting and displaying formatted weight transmissions from digital weight indicators. Additionally they can be used to display text.

The remote displays are addressable which allows a single device to send targeted information to multiple displays. They support firmware upgrades via an optical link on the front.

These units are suitable to use in external applications and are designed to be weather resistant. An optional weather hood is available to minimise effects of direct sunlight. The unit can be wall mounted or fixed onto an optional pole and swivel mounting.

1.2. Document Scope

This manual covers the physical installation of a display, its power and serial connections and the various network protocols that are supported. It is intended for use by Scale Technicians who are installing and maintaining the unit.

2. Specifications

Display	
Display	Up to seven (7) Electromechanical digits for displaying full alpha numeric characters <ul style="list-style-type: none"> • 125 (H) x 78 (W) mm, 4.9 (H) x 3.1 (W) inches • 35 segments per digit Up to seven (7) LED digits with decimal points for displaying numeric and semi-alpha characters <ul style="list-style-type: none"> • 120 (H) x 78 (W) mm, 4.7 (H) x 3.1 (W) inches • 68 LED's per digit Status annunciators for Motion, Centre of Zero and Net
Performance	
Visibility	Up to 40m, 131 feet
Update Rate	10Hz
Operating Environment	Temperature: -10 to +50°C, 14 to 122°F case temperature Humidity: <90%rh non-condensing Storage: -20 to +50°C, -4 to 122°F ambient
Digital	
Setup	Automatic
Memory	Full non-volatile operation
Dimensions	
External Dimensions	850 (L) x 202 (H) x 109 (D) mm 33.5 (L) x 7.9 (H) x 4.3 (D) inches
Display Window	671(L) x 141(H) mm 26.4 (L) x 5.6 (H) inches
Weight	3.4 kg 7.5 lb
Power	
AC Power	110/240VAC 50/60Hz 25W
DC Power	12-24VDC 28W
Features	
Serial Inputs	RS232 – two wire, receive only RS485 – two wire, receive only 20mA Current Loop - receive only
Optical Data Communications	Magnetically coupled optical communications for firmware upgrades.
Approvals	FCC, CE, C-tick
	Check trade approvals
	Unit addressing (up to 8 addresses supported)
	Display timeout available
	Font selectable for curved or blocked
Options	
	Weather Hood
	Pole Mount
	Swivel Mount

3. Display

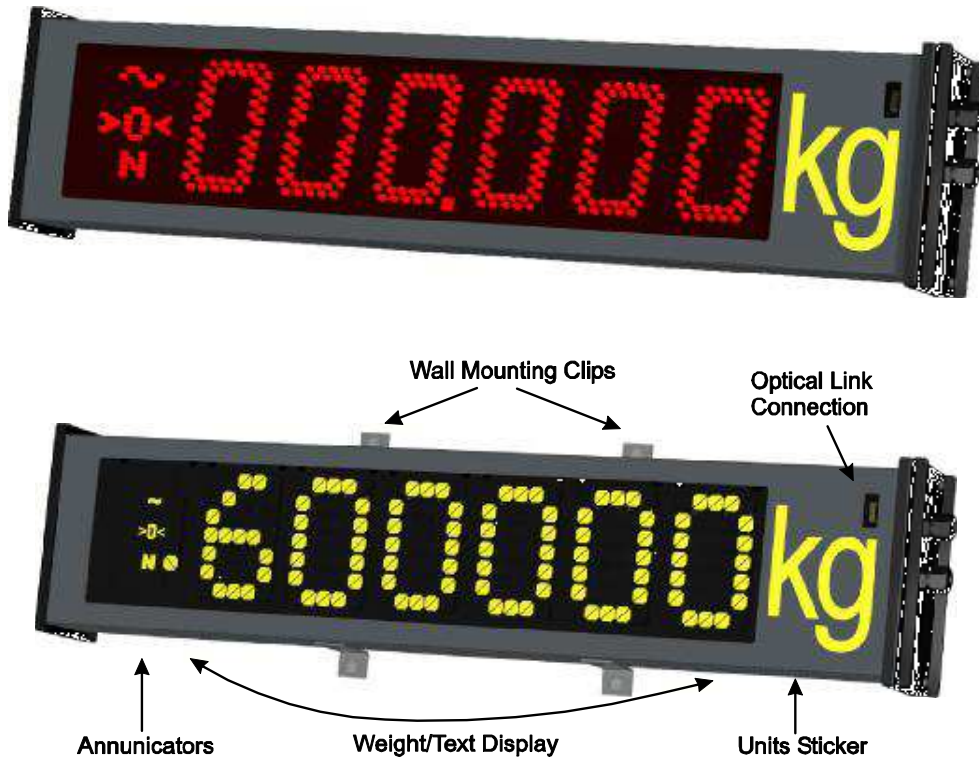

Figure 1 - Display Components

Annunciator – where the annunciator board is fitted, there are three annunciator conditions, detailed in the following table. (Note: Some protocols do not support all annunciators)

Symbol	Name	Description
→0←	ZERO	Lit when the indicator is displaying centre of zero.
N	NET	Lit when the indicator shows NET weight.
~	MOTION	Lit when the indicator reading is not stable.

Weight Display – Up to seven (7) digits if annunciator option not used, shows the weight readings, setup information and errors.

Units - Sticker to indicate the units of the reading.

Opto-link Connection – Optical link connection point for firmware upgrades.

4. Installation

4.1. Overview

This section covers the mounting and electrical connections for the remote displays. These units contain precision electronics and must not be subjected to shock, excessive vibration, or extremes of temperature, either before or after installation.

The serial and power inputs of the displays are protected against electrical interference; however excessive levels of electro-magnetic radiation may effect the operation of the instrument. They should be installed away from any sources of electrical noise and the power and data cables should run separately from other sources of electrical noise.

The installation covers:

- Dipswitch settings
- Application of decimal point (if being used)
- Serial connection
- Power connection
- Mounting – either to a flat surface using mounting clips or to an optional pole or swivel mounting kit.

4.2. Installation Preparation

To access the dipswitches, serial and power connections remove the end plate (held by four screws) then slide the mask assembly out. Slide out only to the point of not dislodging the case earth connection near the power connection. Note: Avoid damaging the opto-link on the front of the mask assembly board.



Warning: Contains Hazardous Voltages. Disconnect power before opening

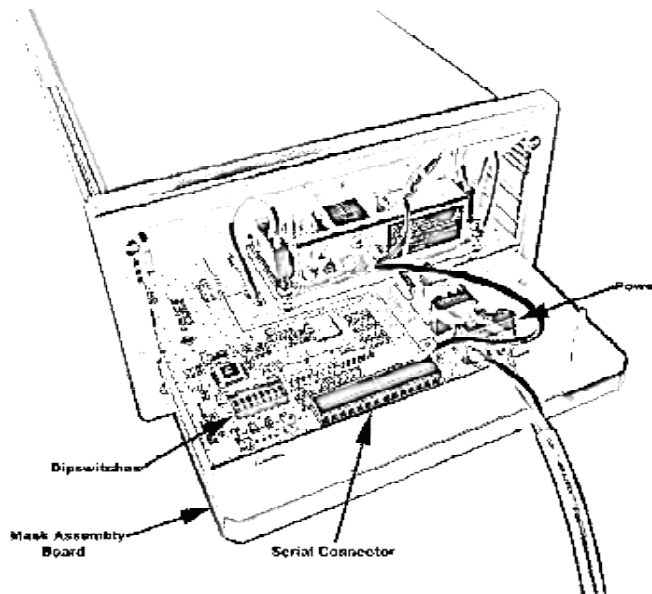

Figure 2 - Internal Connections and Dipswitches

4.3. Dipswitches

The eight (8) dipswitches are located on the left hand side of the board near the serial connection, and are labelled 1-8. The table below lists the use of each dipswitch.

	Address	Address	Address	Protocol Group	Protocol Group	Lock Comms	Display Font	Decimal Point Treatment
DIPSWITCH	1	2	3	4	5	6	7	8
Unit Address								
Address 0 - Broadcast	OFF	OFF	OFF					
Address 1	ON	OFF	OFF					
Address 2	OFF	ON	OFF					
Address 3	ON	ON	OFF					
Address 4	OFF	OFF	ON					
Address 5	ON	OFF	ON					
Address 6	OFF	ON	ON					
Address 7	ON	ON	ON					
Protocol Groups								
Protocol Group 0				OFF	OFF			
Protocol Group 1				ON	OFF			
Protocol Group 2 - unused				OFF	ON			

Protocol Group 3 - unused				ON	ON			
Lock Comms Settings								
Disabled						OFF		
Enabled						ON		
Electro-mechanical Font								
Block straight font						OFF		
Curved font						ON		
Decimal Point								
Displayed								OFF
Not Displayed								ON

4.4. Unit Addressing

The first three dipswitches set the unit address (eight addresses). Note that unit addressing is not supported by some protocols.

4.5. Protocol Grouping

Dipswitches 4 and 5 set the protocol group.

Protocol Group 0

Setting the dipswitches to Protocol Group 0 means that the unit will attempt to automatically detect one of the protocols described in section 5, Protocol Group 0, page 17. The Protocol Table below lists the suggested corresponding manufacturer that each protocol aims to support. Note that compatibility is not guaranteed and manufacturers may change their protocol at any time without advice.

Protocol Group	Protocol	Name	Protocol commonly used by indicators from:
0	1	Ranger A	GSE, HBM, PT, Rinstrum, Systec
0	2	Ranger B	Rinstrum
0	3	Ranger C	GSE, HBM, PT and Rinstrum
0	4	Ranger D	Rinstrum
0	5	PCMODE	Custom software
0	6	R series register write	GSE, Rinstrum
0	7	Avery string #7	Avery L105
0	8	Gedge C2	Gedge
0	9	Gedge C3	Gedge
0	10	AD standard string	A & D
0	11	AD4531	A & D
0	12	Toledo continuous	Toledo
0	13	GSE without COZ	GSE
0	14	GSE with COZ	GSE
0	15	Schenck without DP	Schenck
0	16	Schenck with DP	Schenck
0	17	Auto control string 1	Auto control
0	18	Auto control string 2	Auto control

0	19	Sartorius	Sartorius
0	20	Soehnle without DP	Soehnle
0	21	Soehnle with DP	Soehnle
0	22	Last resort numbers	
1	1	Text	

Protocol Group 1

When set to group 1, the unit will look for up to 8 printable characters to display, refer to section 6, Protocol Group 1 – Text Only, page 39 for further information.

4.6. Lock Communication Settings

Dipswitch 6 sets the communication settings lock. When set to OFF, locking is disabled and the display will start scanning all communication ports after not receiving any data for 2 seconds. When set to ON, the locking is enabled and the display will only accept communications on the port and baud rate that it last received valid communication, even after power is lost. Note: If the stored communications settings are not valid the display will start searching until it finds valid communication at which point it will lock again.

4.7. Decimal Point

4.7.1. LED Unit

The LED unit allows for the decimal point to be optionally displayed.

Decimal Point	Dipswitch 8	Comment
Displayed	OFF	A decimal point will be displayed (all digits are still available) if it is in the received data.
Not Displayed	ON	The decimal point will not be displayed.

4.7.2. Electromechanical Unit

The E/M unit allows for the decimal point to be optionally displayed. Alternatively, a sticker is to be used.

Decimal Point	Dipswitch 8	Comment
Displayed	OFF	A full digit will be used for the decimal point
Not Displayed	ON	The decimal point will not be displayed which allows for a decimal point sticker to be used inside the unit.

◆ Affixing the decimal point sticker

To affix the decimal point sticker turn the unit over to access the front of the mask and place the sticker between appropriate digits, as shown in the figure below. Note that the case earth will need to be disconnected and reconnected to allow the mask assembly to be slid out to access the digits.

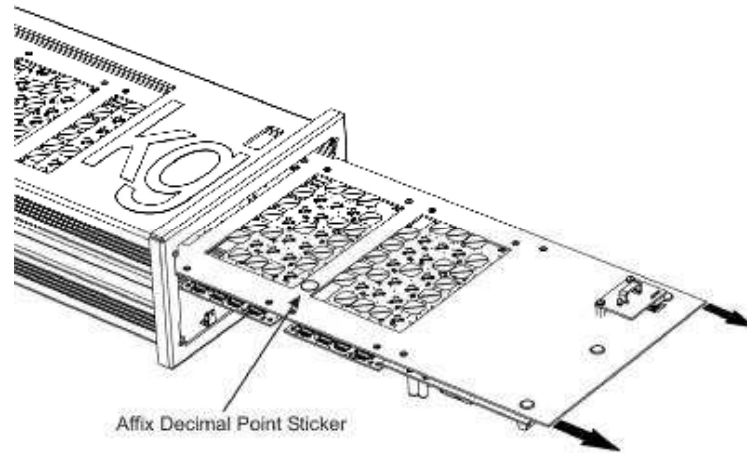

Figure 3 - Application of Decimal Point Sticker

4.8. Serial Connection

The serial connection receives the data to display. It is located on the left of the mask assembly board near the dipswitches as shown in Figure 2 - Internal Connections and Dipswitch. The connections are numbered left to right, 1 being furthest to the left near the dipswitches.

A shielded data cable should be used to prevent electrical noise interfering with the signal on the cable, and thereby the operation of the unit. The data cable should be run through the upper gland of the end plate, through the gasket and the cable sheath cut back around 50mm before being connected to the terminal blocks.

Both units have a single serial connection that automatically scans for data. There are three serial port connection types:

- RS232 isolated receive only
- RS485 isolated receive only
- 20mA Current Loop isolated receive only



Warning: If using the 24V supply to power a current loop, ensure that external current limiting is provided otherwise damage may occur to both units.

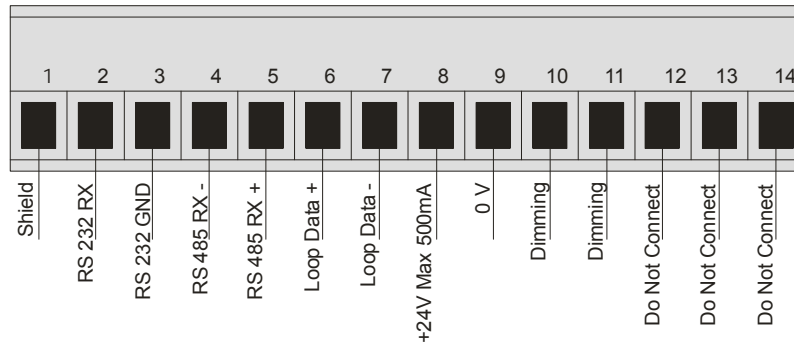

Figure 4 - Serial Connection Pin out

4.8.1. Baud Rate and Parity

Baud rate, parity and data bits are automatically detected. The baud rate can be 2400, 4800, 9600 or 19200. Parity and data bits supported are:

Parity	Databits	Examples	Description
(N)one	8	N81, N82	No parity, 8 data bits, 1 or 2 stop bits
(E)ven	7	E71, E72	Even parity, 7 data bits, 1 or 2 stop bits
(O)dd	7	O71, O72	Odd parity, 7 data bits, 1 or 2 stop bits
(M)ark	7	M71, M72	Mark parity, 7 data bits, 1 or 2 stop bits
(S)pace	7	S71, S72	Space parity, 7 data bits, 1 or 2 stop bits

4.8.2. Earthing Requirements for Cable Shields

Cable shields should ideally be connected to earth at one end only for each of the communications options below. Pin 1 on the serial connection is internally connected to earth and provides a convenient location to terminate the serial cable shield.

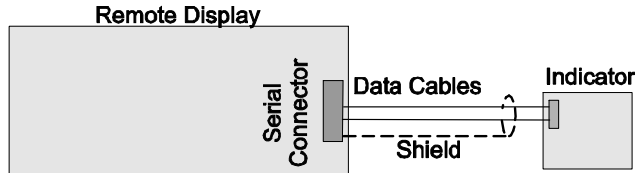

Figure 5 - Shield Earthing

4.8.3. Powering Indicator from Remote Display (Pins 8 and 9)

Pins 8 and 9 provide a 24V DC supply at a maximum current draw of 250mA. This supply can be used to power the weighing indicator. In such installations a single serial cable with four (4) conductors joins the indicator and the remote display. Two conductors supply power to the indicator and two conductors are used for data transmission.

4.8.4. Dim LED Display (Pins 10 and 11)

For internal applications or for use in dimly lit areas, the LED display may be too bright for comfort. The display can be dimmed by shorting pins 10 and 11 and an external switch can be used.

4.8.5. RS232 Receive Only

RS232 is not suitable for long cable runs or electrically noisy environments. It uses pins 2 and 3 as shown in Figure 6 - RS232 Connection. Earthing is discussed in Earthing Requirements for Cable Shields page 11.

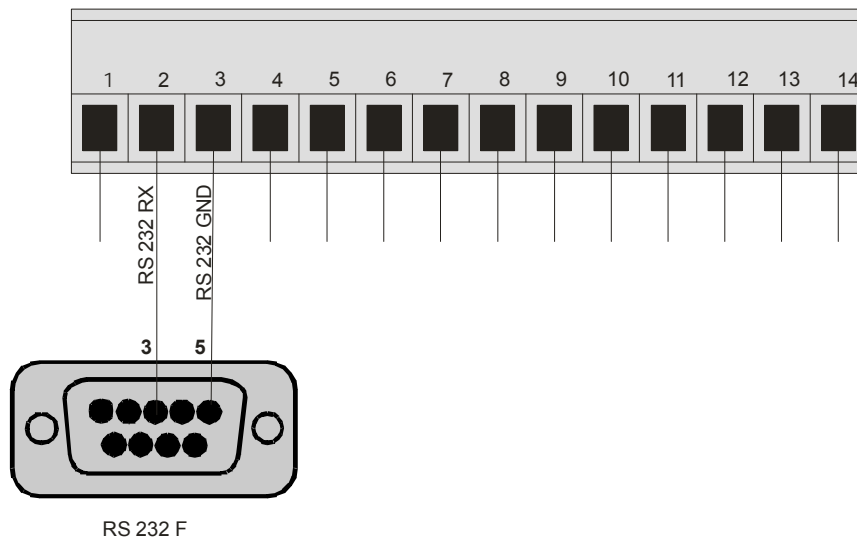

Figure 6 - RS232 Connection

4.8.6. RS485 Receive Only

RS485 is the preferred serial connection and uses pins 4 and 5 as shown in Figure 7 - RS485 Connection. Earthing is discussed in Earthing Requirements for Cable Shields page 11.

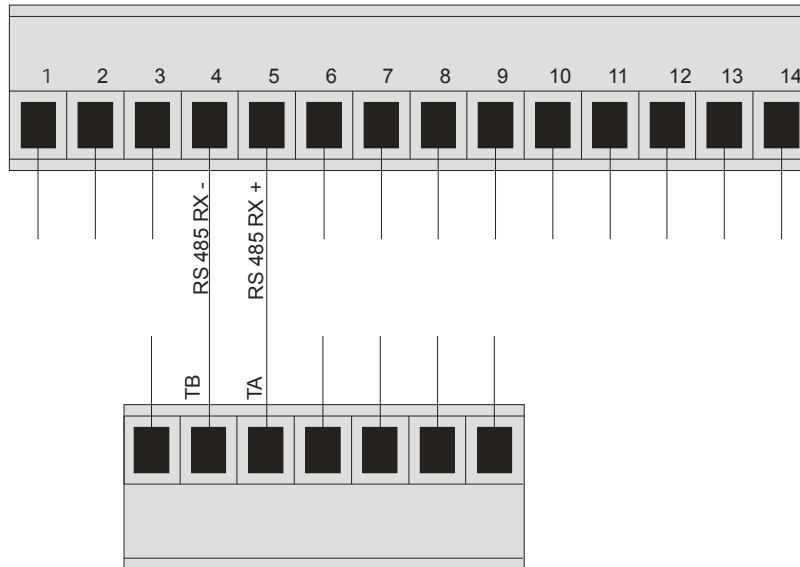

Figure 7 - RS485 Connection

4.8.7. 20mA Current Loop Receive Only



Warning: If using the 24V supply to power a current loop, ensure that external current limiting is provided otherwise damage may occur to both units.

Both units are fitted with a 20mA Current Loop receiver. It is a passive receiver meaning it is not current limited and requires external current limiting on the loop current. Therefore either your transmitter or an external device must limit the loop current. A 1.2k 0.5W resistor is recommended if using the 24V supply to power the current loop. The connection to a passive loop transmitter is shown in Figure 8 - 20mA Current Loop. Earthing is discussed in Earthing Requirements for Cable Shields page 11.

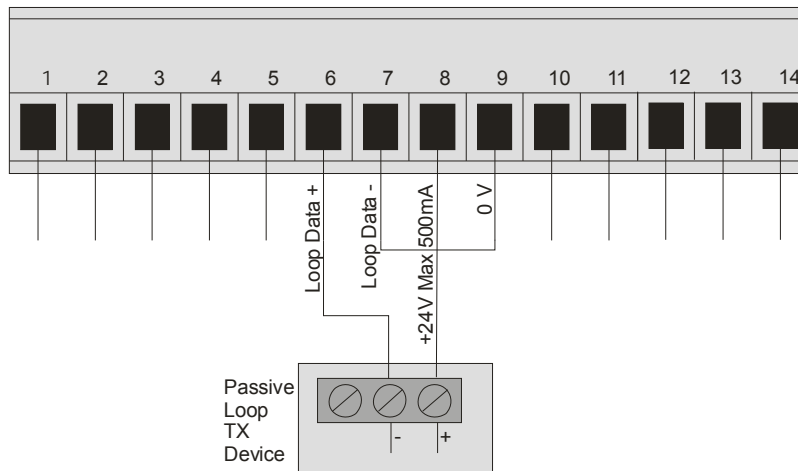

Figure 8 - 20mA Current Loop – Passive Loop Transmitter

4.9. Power Connection



Warning: Both units contain Hazardous Voltages. Disconnect power before opening

AC units operate from an AC power source between 110VAC and 240VAC. The power connection should be performed under local regulations. The earth **MUST** be connected for both safety and EMC regulation compliance.

DC units operate from a DC power source between 12VDC and 24VDC. For the display to power up, 12-24VDC must also be connected to the IG (ignition) input. The ignition input is a low current input, and is useful in applications where the display must be switched on by a low current source.

Run power cable through the gland of the end plate and connect as per the appropriate diagram below.

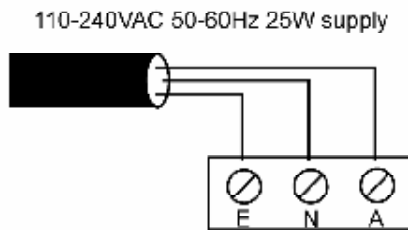

Figure 9 AC power supply connection

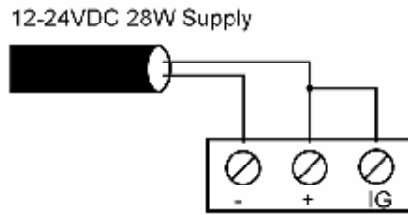

Figure 10 DC Always on connection

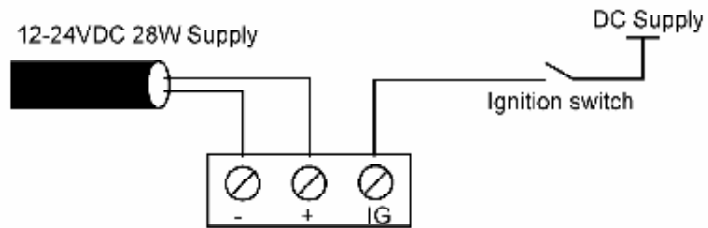

Figure 11 DC switched connection

4.10. Mounting

4.10.1. Clip Attachment

Four stainless steel mounting clips (two top and two for the bottom) are used to mount the unit on a flat surface. The clips slot into the front channel in the top and bottom of the case, as shown in the figure. The hole in each clip is 7mm in diameter.

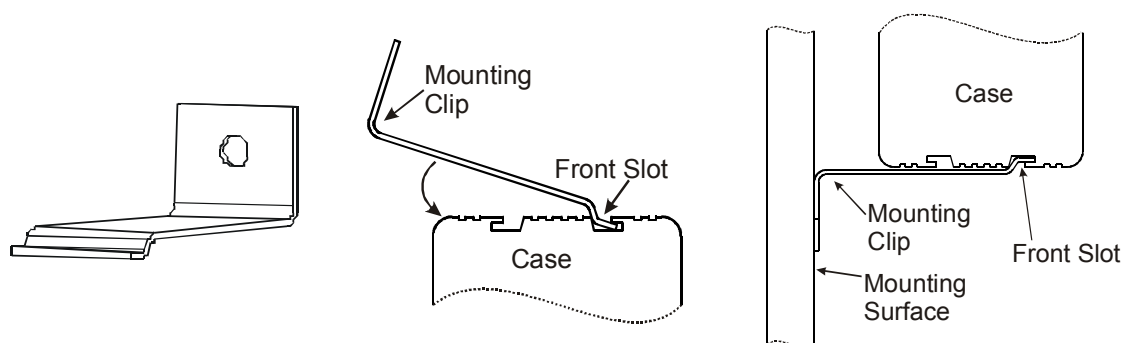

Figure 12 - Mounting Clip Attachment 1



Figure 13 - Mounting Clip Attachment 2

4.10.2. Wall Mounting

For wall mounting it is recommended that:

- 6mm or 1/4" bolts be used;
- all four clips are used (two on the top and two on the bottom) and
- to support the optional Weather Hood the mounting holes must be 268mm apart as it connects to the top mounting clips.

It is suggested that the two lower clips are attached first. Then with the top of the unit angled outward from the wall the two clips can be inserted into the front channel on the bottom of the case. While holding the unit, the top brackets can be

inserted to line up with the bottom brackets to allow the top holes to be marked for drilling.

4.11. Weather Hood

These units are suitable to use in external applications and are designed to be weather resistant (note: on the underside of the extrusion are two breather holes and as such the area should not be subject to high pressure water). An optional weather hood is available to minimise effects of direct sunlight.

4.12. Mounting Options

Optional pole mounting and swivel mounting kits are available, along with a weather shield option. Swivel mount is shown below.

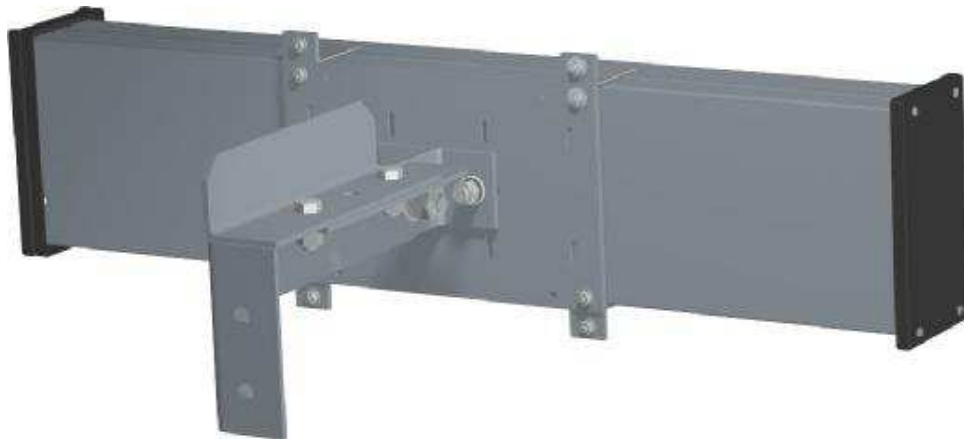

5. Protocol Group 0

5.1. Overview

The protocols listed in this section are within Protocol Group 0. As discussed in section 4.3, Dipswitches, page 6, dipswitches 4 and 5 set the Protocol Group.

5.2. Protocol 1

Character Number	0	1	2	3	4	5	6	7	8	9	10
Description	STX	Sign	Weight	Weight	Weight	Weight	Weight	Weight	Weight	Status	ETX

Function	Description
STX	Start of Transmission Character (ASCII 02H).
Sign	Represents the sign of the weight reading (space for positive, dash (-) for negative).
Weight	<p>These seven characters are a string containing the current weight including the decimal point. If there is no decimal point, then the first character is a space.</p> <p>Examples:</p> <p>(300) with a leading space would represent 300 units.</p> <p>(3.00) Is another acceptable string.</p>
Status	<p>The status character provides information on the weight reading. The characters G/N/U/O/M/E represent Gross/Net/Underload/Overload/Motion/Error, respectively. A space (ASCII 20H) can also be sent. This character may only represent one status at any one time.</p>
ETX	End of Transmission character (ASCII 03H).

5.3. Protocol 2

Character Number	0	1	2	3	4	5	6	7	8	9	10
Description	STX	Status	Sign	Weight	Weight	Weight	Weight	Weight	Weight	Weight	Units
Character Number	11	12	13								
Description	Units	Units	ETX								

Function	Description
STX	Start of Transmission Character (ASCII 02H).
Sign	Represents the sign of the weight reading (space for positive, dash (-) for negative).
Weight	These seven characters are a string containing the current weight including the decimal point. If there is no decimal point, then the first character is a space. Examples: (300) with a leading space would represent 300 units. (3.00) Is another acceptable string.
Status	The status character provides information on the weight reading. The characters G/N/U/O/M/E represent Gross/Net/Underload/Overload/Motion/Error, respectively. A space (ASCII 20H) can also be sent. This character may only represent one status at any one time.
Units	Not used by the remote display.
ETX	End of Transmission character (ASCII 03H).

5.4. Protocol 3

Character Number	0	1	2	3	4	5	6	7	8	9	10
Description	STX	Sign	Weight	Weight	Weight	Weight	Weight	Weight	Weight	S1	S2
Character Number	11	12	13	14	15	16					
Description	S3	S4	Units	Units	Units	ETX					

Function	Description
STX	Start of Transmission Character (ASCII 02H).
Sign	Represents the sign of the weight reading (space for positive, dash (-) for negative).
Weight	These seven characters are a string containing the current weight including the decimal point. If there is no decimal point, then the first character is a space. Examples: (300) with a leading space would represent 300 units. (3.00) is another acceptable string, note that when the decimal point is added the leading space is removed.
S1	Can be G/N/U/O/E representing Gross/Net/Underload/Overload/Error, respectively. A space (ASCII 20H) can also be sent. This character may only represent one status at any one time.
S2	Can be M representing motion or a space to represent stable.
S3	Set to Z representing centre of zero or a space to represent non-zero.
S4	Set to one (1) to represent range one in dual-interval and dual range mode, set to two (2) to represent range two in dual-interval and dual range mode, otherwise send a dash (-).
Units	Not used by the remote display.
ETX	End of Transmission character (ASCII 03H).

5.5. Protocol 4

Character Number	0	1	2	3	4	5	6	7	8	9
Description	STX	Sign	Weight	Weight	Weight	Weight	Weight	Weight	Weight	ETX

Function	Description
STX	Start of Transmission Character (ASCII 02H).
Sign	Represents the sign of the weight reading (space for positive, dash (-) for negative).
Weight	<p>These seven characters are a string containing the current weight including the decimal point. If there is no decimal point, then the first character is a space.</p> <p>Examples:</p> <p>(300) with a leading space would represent 300 units.</p> <p>(3.00) Is another acceptable string.</p>
ETX	End of Transmission character (ASCII 03H).

5.6. Protocol 5

Character Number	0	1	2	3	4	5	6	7	8	9	10	11	12
Description	STX	Text	Text	Text	Text	Text	Text	Text	Text	SPC	Address(0)	Address (1)	ETX

Function	Description
STX	Start of Transmission Character (ASCII 02H).
Text	<p>These eight (8) characters will be displayed. They may be ASCII characters instead of numbers in which case the display will show text. These eight characters can include a decimal point and a leading minus to indicate sign. Example:</p> <p>(300) would represent 300 units.</p> <p>(- 3.00) a decimal point and minus sign can be used.</p> <p>(CEMENT) text can be sent.</p> <p>A capital L in position 1 will disable the remote display data timeout and can be used to lock the message on the display until new data is sent.</p>
SPC	Space character (ASCII 20H).
Address	A two character field specifying the address of the unit to display the message. Where 00 is the broadcast address. Note the actual address of a display is set by dipswitches 1-3 refer to 4.3 Dipswitches page 6.
ETX	End of Transmission character (ASCII 03H).

5.7. Protocol 6

Character Number	0	1	2	3	4	5	6	7	8	9	10	11	12
Description	Address(0)	Address(1)	Command (0)	Command (1)	Register(0)	Register(1)	Register(2)	Register(3)	Semicolon	Data(0)	Data(1)	Data(2)	Data(3)
Character Number	13	14	15	16	17	18							
Description	Data(4)	Data(5)	Data(6)	Data(7)	Terminator (0)	Terminator (1)							

Function	Description
Address	A two character field specifying the address of the unit to display the message. Where 00 is the broadcast address. Note the actual address of a display is set by dipswitches 1-3 refer to 4.3 Dipswitches page 6.
Command(0-1)	Must be 12 (ASCII 31H, ASCII 32H).
Register(0-3)	Must be 000E (ASCII 30H, ASCII 30H, ASCII 30H, ASCII 45H).
Semicolon	This byte must be a semicolon (ASCII 3BH).
Data(0-7)	This is the string to be displayed on the Remote Display and may consist of text and or numbers.
Terminator(0-1)	These two characters signify the end of the signal and are represented by a carriage return and then a line feed or CRLF (ASCII 0D, ASCII 0A).

Note: When using this protocol the display timeout is disabled, which means that the message will remain on the display until new data is sent.

5.8. Protocol 7

Character Number	0	1	2	3	4	5	6	7	8	9	10	11	12
Description	STX	Weight(0)	Weight(1)	Weight(2)	Weight(3)	Weight(4)	Weight(5)	Weight(6)	SPC	Units(0)	Units(1)	Units(2)	Units(3)
Character Number	13	14	15	16	17	18	19	20	21	22	23	24	25
Description	Units(4)	SPC	S1	SPC	Con(0)	Con(1)	Con(2)	Con(3)	Con(4)	Con(5)	SPC	Ignore	CR
Character Number	26	27											
Description	LF	ETX											

Function	Description
STX	Start of Transmission Character (ASCII 02H).
Weight	The numbers to be displayed on the remote display. These seven characters can include a decimal point and a leading minus to indicate sign. E.g. (300) with leading spaces would represent 300 units. (3.00) Is another acceptable string, this time with a decimal point instead of one of the characters. (-30.000) Here we have the weight with the sign attached. Note because of the sign and the decimal point only five number characters are sent.
Units	Not used by the remote display.
SPC	Space character (ASCII 20H).
S1	Can be G or N to indicate Gross or Net respectively.
Con	Consecutive numbers, are not used by the remote display.
CR	Carriage Return character (ASCII 0DH)
LF	Line Feed character (ASCII 0AH)
ETX	End of Transmission character (ASCII 03H).

5.9. Protocol 8

Character Number	0	1	2	3	4	5	6	7	8	9	10	11	12
Description	STX	Weight(0)	Weight(1)	Weight(2)	Weight(3)	Weight(4)	Weight(5)	Weight(6)	Weight(7)	S1	S2	S3	Ignore
Character Number	13	14	15										
Description	SPC	SPC	ETX										

Function	Description
STX	Start of Transmission Character (ASCII 02H).
Weight(0-7)	The numbers to be displayed on the remote display. These eight characters can include a decimal point and a leading minus to indicate sign. E.g. (00000300) with leading zeroes would represent 300 units. (00003.00) Is another acceptable string, this time with a decimal point instead of one of the characters. (-0003.00) Here we have the weight with the sign attached. Note because of the sign and the decimal point only six number characters are sent.
S1	Can be G or N to indicate Gross or Net respectively.
S2	Can be M or S to indicate Motion or Stable respectively
S3	Can be I,O or U to indicate In scale, Over range or Under range respectively.
SPC	Space character (ASCII 20H).
ETX	End of Transmission character (ASCII 03H).

5.10. Protocol 9

Character Number	0	1	2	3	4	5	6	7	8	9	10	11	12
Description	STX	Gross(0)	Gross(1)	Gross(2)	Gross(3)	Gross(4)	Gross(5)	Gross(6)	Gross(7)	Tare(0)	Tare(1)	Tare(2)	Tare(3)
Character Number	13	14	15	16	17	18	19	20	21	22	23	24	25
Description	Tare(4)	Tare(5)	Tare(6)	Tare(7)	Net(0)	Net(1)	Net(2)	Net(3)	Net(4)	Net(5)	Net(6)	Net(7)	S1
Character Number	26	27	28	29	30	31							
Description	S2	S3	Ignore	SPC	SPC	ETX							

Function	Description
STX	Start of Transmission Character (ASCII 02H).
Gross	The numbers to be displayed on the remote display When S1 equals G. These eight characters can include a decimal point and a leading minus to indicate sign. E.g. (00000300) with leading zeroes would represent 300 units. (00003.00) Is another acceptable string, this time with a decimal point instead of one of the characters. (-0003.00) Note because of the sign and the decimal point only six number characters are sent.
Tare	Not used by the remote display
Net	The numbers to be displayed on the remote display When S1 equals N. These eight characters can include a decimal point and a leading minus to indicate sign. Examples as for Gross.
S1	Can be G or N to indicate Gross or Net respectively.
S2	Can be M or S to indicate Motion or Stable respectively
S3	Can be I,O or U to indicate In scale, Over range or Under range respectively.
SPC	Space character (ASCII 20H).
ETX	End of Transmission character (ASCII 03H).

5.11. Protocol 10

Character Number	0	1	2	3	4	5	6	7	8	9	10	11	12
Description	HeaderA(0)	HeaderA(1)	Comma	HeaderB(0)	HeaderB(1)	Comma	Sign	Weight(0)	Weight(1)	Weight(2)	Weight(3)	Weight(4)	Weight(5)
Character Number	13	14	15	16	17								
Description	Weight(6)	Units(0)	Units(1)	CR	LF								

Function	Description
HeaderA	This header can be ST, UN or OL representing stable, unstable and out of scale range.
Comma	Comma (ASCII 2CH).
HeaderB	This second header can be GS - gross weight, NT - Net weight, TR - Tare and PT - Preset Tare. The NET annunciator will be on for Net weight and off for all other weights.
Sign	The sign of the weight reading (plus (+) for positive, dash (-) for negative). It is also used to show the direction of out of scale range: + for overload and – for underload.
Weight	These seven characters are a string containing the current weight including the decimal point. If there is no decimal point, then the last character is a period. Leading zero blanking applies. During overload or underload the weight reading will be spaces. E.g. (000300.) Note the trailing period, this string would represent 300 units. (0003.00) Is another acceptable string, note that when the decimal point is added the period at the end is removed.
Units	Not used by the remote display.
CR	Carriage Return character (ASCII 0DH).
LF	Line Feed character (ASCII 0AH).

5.12. Protocol 11

Character Number	0	1	2	3	4	5	6	7	8	9	10
Description	Header(0)	Header(1)	Comma	Sign	Weight(0)	Weight(1)	Weight(2)	Weight(3)	Weight(4)	CR	LF

Function	Description
Header	This header can be WT when in normal mode or OL to represent out of scale range.
Comma	Comma (ASCII 2CH).
Sign	The sign of the weight reading (plus (+) for positive, dash (-) for negative). If the unit rests at zero the sign will be a plus. It is also used to show the direction of out of scale range: + for overload and – for underload.
Weight	These five characters are a string containing the current weight including the decimal point. If there is no decimal point, then a preceding zero is used. Leading zero blanking applies. During overload or underload the weight reading will be 99.99 with the sign representing which one it is. E.g. (00300) This string would represent 300 units. (03.00) Shows the string format when a decimal point is added.
CR	Carriage Return character (ASCII 0DH).
LF	Line Feed character (ASCII 0AH).

5.13. Protocol 12

Character Number	0	1	2	3	4	5	6	7	8	9	10	11	12
Description	STX	SW(A)	SW(B)	SW(C)	Weight (0)	Weight (1)	Weight (2)	Weight (3)	Weight (4)	Weight (5)	Tare(0)	Tare(1)	Tare(2)
Character Number	13	14	15	16									
Description	Tare(3)	Tare(4)	Tare(5)	CR									

Function	Description
STX	Start of Transmission Character (ASCII 02H).
SW	SW A, B and C are each a collection of status bits. The relevant bits of the three characters are shown below in tabular form. All other status bits are ignored.
Weight	These six characters are a string containing the current gross or net weight not including the decimal point or a sign.
Tare	Not used by the remote display
CR	Carriage return character ASCII 0D.

SW A Bits 0,1 and 2			
Bits			Decimal Point Location
0	1	2	
0	0	0	XXXX00
1	0	0	XXXXX0
0	1	0	XXXXXX
1	1	0	XXXXX.X

SW B Bits 0,1,2 and 3	
Status Bits	Function
Bit 0	Gross = 0, Net = 1
Bit 1	Sign, Positive = 0, Negative = 1
Bit 2	Out of Range = 1 (Either overload or underload)
Bit 3	Motion = 1

5.14. Protocol 13

Character Number	0	1	2	3	4	5	6	7	8	9	10	11	12
Description	Weight(0)	Weight(1)	Weight(2)	Weight(3)	Weight(4)	Weight(5)	Weight(6)	Weight(7)	SPC	Units(0)	Units(1)	Units(2)	Units(3)
Character Number	13	14	15	16	17	18	19	20	21	22			
Description	Units(4)	SPC	Mode(0)	Mode(1)	Mode(2)	Mode(3)	Mode(4)	S1	CR	LF			

Function	Description
Weight	<p>The numbers to be displayed on the remote display. These eight characters can include a decimal point and a leading minus to indicate sign. E.g.</p> <p>(300) would represent 300 units.</p> <p>(3.00) Is another acceptable string, this time with a decimal point instead of one of the characters.</p> <p>(- 3.00) Note because of the sign and the decimal point only six number characters are sent.</p>
Units	Not used by the remote display.
Mode	Gross, Net or Tare with trailing spaces. Used to actuate the Net annunciator
S1	M = Motion, S = Stable, O = Overload or Underload, E = Error
CR	Carriage return character (ASCII 0DH).
LF	Line feed character (ASCII 0AH).
SPC	Space character (ASCII 20H).

5.15. Protocol 14

Character Number	0	1	2	3	4	5	6	7	8	9	10	11	12
Description	Weight(0)	Weight(1)	Weight(2)	Weight(3)	Weight(4)	Weight(5)	Weight(6)	Weight(7)	SPC	Units(0)	Units(1)	Units(2)	Units(3)
Character Number	13	14	15	16	17	18	19	20	21	22	23		
Description	Units(4)	SPC	Mode(0)	Mode(1)	Mode(2)	Mode(3)	Mode(4)	S1	S2	CR	LF		

Function	Description
Weight	<p>The numbers to be displayed on the remote display. These eight characters can include a decimal point and a leading minus to indicate sign. E.g.</p> <p>(300) would represent 300 units.</p> <p>(3.00) Is another acceptable string, this time with a decimal point instead of one of the characters.</p> <p>(- 3.00) Note because of the sign and the decimal point only six number characters are sent.</p>
Units	Not used by the remote display.
Mode	Gross, Net or Tare with trailing spaces. Used to actuate the Net annunciator
S1	M = Motion, S = Stable, O = Overload or Underload, E = Error
S2	Z = Centre of Zero, Space for not centre of zero
CR	Carriage return character (ASCII 0DH).
LF	Line feed character (ASCII 0AH).
SPC	Space character (ASCII 20H).

5.16. Protocol 15

Character Number	0	1	2	3	4	5	6	7	8	9	10	11	12
Description	STX	Ignore	Ignore	Ignore	Sign	Net(0)	Net(1)	Net(2)	Net(3)	Net(4)	Tare(0)	Tare(1)	Tare(2)
Character Number	13	14	15	16	17	18	19	20	21	22	23		
Description	Tare(3)	Tare(4)	Tare(5)	Tare(6)	Tare(7)	Tare(8)	SPC	S1	S2	LF	CR		

Function	Description
STX	Start of Transmission Character (ASCII 02H).
Sign	Represents the sign of the weight reading (space for positive, dash (-) for negative).
Net	The numbers to be displayed on the remote display. E.g. (300) would represent 300 units.
Tare	Not used by the remote display.
SPC	Space character (ASCII 20H).
S1	ASCII character (0-F) with values as shown in the table below
S2	ASCII character (0-F) with values as shown in the table below
LF	Line feed character (ASCII 0AH).
CR	Carriage return character (ASCII 0DH).

S1 Bit	S1 Status
0	Tare=0, preset Tare=1 Only used in net mode.
1	Motion = 0, Stable=1
2	Not COZ=0, COZ=1
3	Gross=0, Net=1

S2 Value	S2 Status
0	Units = kg
1	Units = g
3	Units = T
5	Weight longer than string, Display will be blanked.

5.17. Protocol 16

Character Number	0	1	2	3	4	5	6	7	8	9	10	11	12
Description	STX	Ignore	Ignore	Ignore	Sign	Net(0)	Net(1)	Net(2)	Net(3)	Net(4)	Net(5)	Tare(0)	Tare(1)
Character Number	13	14	15	16	17	18	19	20	21	22	23	24	25
Description	Tare(2)	Tare(3)	Tare(4)	Tare(5)	Tare(6)	Tare(7)	Tare(8)	Tare(9)	SPC	S1	S2	LF	CR

Function	Description
STX	Start of Transmission Character (ASCII 02H).
Sign	Represents the sign of the weight reading (space for positive, dash (-) for negative).
Net	The numbers to be displayed on the remote display. These six characters include a decimal. E.g. (300.0) with leading spaces would represent 300 units.
Tare	Not used by the remote display
SPC	Space character (ASCII 20H).
S1	ASCII character (0-F) with values as shown in the table below
S2	ASCII character (0-F) with values as shown in the table below
LF	Line feed character (ASCII 0AH).
CR	Carriage return character (ASCII 0DH).

S1 Bit	S1 Status
0	Tare=0, preset Tare=1 Only used in Net mode.
1	Motion = 0, Stable=1
2	Not COZ=0, COZ=1
3	Gross=0, Net=1

S2 Value	S2 Status
0	Units = kg
1	Units = g
3	Units = T
5	Weight longer than string, Display will be blanked.

5.18. Protocol 17

Character Number	0	1	2	3	4	5	6
Description	STX	Address	Weight(0)	Weight(1)	Weight(2)	Weight(3)	ETX

Function	Description
STX	Start of Transmission Character (ASCII 02H).
Address	A single character field specifying the address of the unit to display the message. The address is fixed as 1 for this string so the unit must be set to address 1 to display this string.
Weight	<p>The numbers to be displayed on the remote display. These four characters can include a decimal point and a leading minus to indicate sign. E.g.</p> <p>(300) with leading space would represent 300 units.</p> <p>(3.00) Is another acceptable string, this time with a decimal point instead of one of the characters.</p> <p>(-3.0) Here we have the weight with the sign attached. Note because of the sign and the decimal point only two number characters are sent.</p>
ETX	End of Transmission character (ASCII 03H).

5.19. Protocol 18

Character Number	0	1	2	3	4	5	6	7	8	9	10
Description	STX	Address	Text(0)	Text(1)	Text(2)	Text(3)	Text(4)	Text(5)	Text(6)	Text(7)	ENQ

Function	Description
STX	Start of Transmission Character (ASCII 02H).
Address	A single character field specifying the address of the unit to display the message. The address is fixed as 2 for this string so the unit must be set to address 2 to display this string.
Text	These eight (8) characters will be displayed. They may be ASCII characters instead of numbers in which case the display will show text. These eight characters can include a decimal point and a leading minus to indicate sign. Example: (300) would represent 300 units. (- 3.00) a decimal point and minus sign can be used. (CEMENT) text can be sent.
ENQ	Used as end of transmission character (ASCII 05H).

5.20. Protocol 19

Character Number	0	1	2	3	4	5	6	7	8	9	10	11	12
Description	Ignore	Ignore	Ignore	Ignore	Ignore	Ignore	Sign	SPC	Weight(0)	Weight (1)	Weight (2)	Weight (3)	Weight (4)
Character Number	13	14	15	16	17	18	19	20	21				
Description	Weight (5)	Weight (6)	Weight (6)	SPC	Units(0)	Units(1)	Units(2)	CR	LF				

Function	Description
Sign	Represents the sign of the weight reading (+ for positive, dash (-) for negative.
Weight	The numbers to be displayed on the remote display. E.g. (300) would represent 300 units.
Units	Not used by the remote display.
SPC	Space character (ASCII 20H).
LF	Line feed character (ASCII 0AH).
CR	Carriage return character (ASCII 0DH).

5.21. Protocol 20

Character Number	0	1	2	3	4	5	6	7	8	9	10
Description	S1	Weight(0)	Weight (1)	Weight (2)	Weight (3)	Weight (4)	ESC	Ignore	Units	CR	LF

Function	Description
S1	N = Net, M = Net + COZ, O = COZ
Units	Set to zero (0) if there is motion, otherwise unused by the display
Weight	The numbers to be displayed on the remote display. E.g. (300) would represent 300 units.
ESC	Escape character (ASCII 1BH).
CR	Carriage return character (ASCII 0DH).
LF	Line feed character (ASCII 0AH).

5.22. Protocol 21

Character Number	0	1	2	3	4	5	6	7	8	9	10	11
Description	S1	Weight (0)	Weight (1)	Weight (2)	Weight (3)	Weight (4)	Weight (5)	ESC	Ignore	Units	CR	LF

Function	Description
S1	N = Net, M = Net + COZ, O = COZ
Units	Set to zero (0) if there is motion, otherwise unused by the display
Weight	The numbers to be displayed on the remote display. E.g. (300) would represent 300 units.
ESC	Escape character (ASCII 1BH).
CR	Carriage return character (ASCII 0DH).
LF	Line feed character (ASCII 0AH).

5.23. Protocol 22

This protocol is used when no matching protocol can be found. This protocol will usually display the weight correctly for unknown protocols.

Character Number		-		1	2	3	4	5	6	7	8		-
Description	~	- Sign	~	Weight (0)	Weight (1)	Weight (2)	Weight (3)	Weight (4)	Weight (5)	Weight (6)	Weight (7)	~	Terminator

Function	Description
Header	Not required
~	This symbol represents an unknown number of characters.
- Sign	The message is scanned for a minus sign (-). If found, the weight is considered to be negative and the unit will display a negative sign (-) if there are sufficient digits.
Weight	The string is scanned from the start of the data looking for any number (0-9). The first number found is considered to be the start of the weight reading. Up to 8 numbers are considered the weight reading. The unit will then display as much of this weight reading (right justified) as possible given the number of digits of the display. Leading zero blanking will be applied. (123) on a 7 digit display will display as "0000123" (12345678) on a 7 digit display will display as "2345678" (-123456) on a 7 digit display will display as "-123456"
Terminator	A Carriage Return (ASCII 0DH) or End of Transmission (ASCII 03H) is acceptable.

6. Protocol Group 1 – Text Only

This protocol displays up to 8 printable characters terminated with a CR or ETX.

Character Number	0	1	2	3	4	5	6	7	~
Description	Text (0)	Text (1)	Text (2)	Text (3)	Text (4)	Text (5)	Text (6)	Text (7)	Terminator

Function	Description
Text	<p>Up to 8 printable characters will be considered as the message. The unit will display as much of this message, right justified, given the number of digits of the display. Eg.</p> <p>(abcd1234) on a 7 digit display will display as “bcd1234”</p> <p>(abc) on a 5 digit display will be displayed as “abc”</p> <p>(abcd123456) will be rejected as too many characters</p>
Terminator	A Carriage Return (ASCII 0DH) or End of Transmission (ASCII 03H) is acceptable.

7. Error Messages

7.1. Weighing Errors

These messages show errors that have occurred during the normal weighing operation.

Error	Description
--U----	Underweight - the weight is below the minimum allowable weight reading.
--O----	Overweight - The weight is above the maximum allowable weight reading.
--E----	Error - The indicator is reporting an error.
-----	No valid data from indicator

Innovative Measurement Electronics



PT Ltd.

<http://www.pt-global.com>