



API 12.369 PT100LC Installation

Product Support.



Introduction.

The PT100LC is designed using the latest SMT technology. It is compact in size, DIN rail mounting, has user selectable outputs and has span and zero calibration. It is suitable for commercial or industrial installations ranging from silo or tank weighing, to platform, hopper and crane weighing.

Connections.

The schematic below indicates the simple connection to 1 to 8 load cells. Be sure to configure the PT100LC before installation. It is possible to use up to 4 pcs. of 350 ohm load

cell.

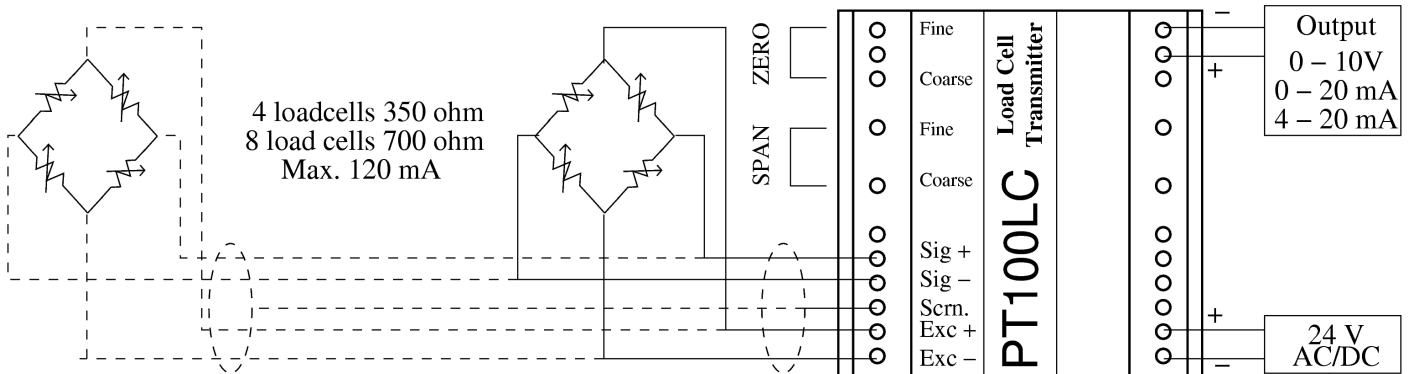

Configuration.

The PT100LC requires configuration of the input sensitivity prior to installation. The transparent cover and green snap case are opened to access all options. If the factory set value for input sensitivity of the PT100LC is the desired setting the green case does not require opening and you can proceed to output format configuration.

• Input sensitivity configuration.

Calculate the expected output from the load cell(s) in mV/V. This is found from the equation;

$$\text{Output} = (\text{load for full output from the PT100LC}) / (\text{number load cells}) / (\text{load cell capacity}) * (\text{load cell mV/V})$$

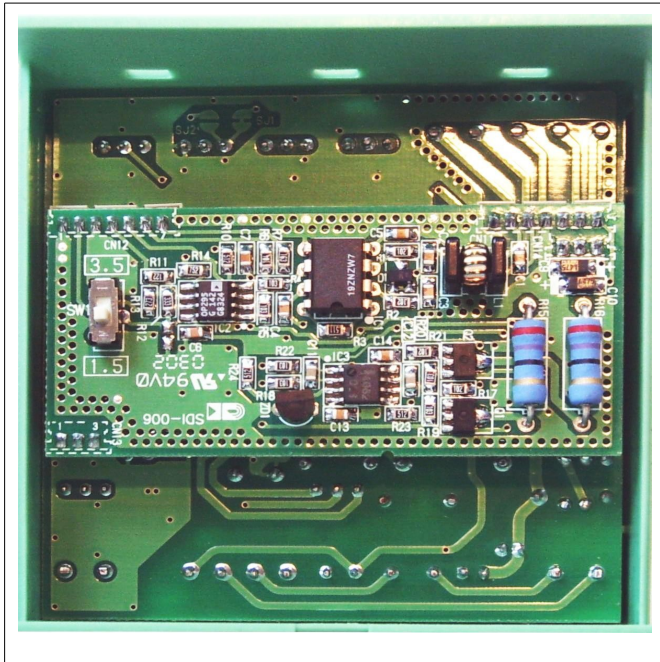

The factory setting for the PT100LC is 1.5 mV/V, if Output from above is greater than this then you must set the input sensitivity to 3.5 mV/V.

Input sensitivity is adjusted with SW1 located inside the case on the underside. The bottom of the case must be removed. The case is opened by inserting a screw driver into the 3 locks (small slots) on each side to depress the tags and prising the case apart. Once apart locate the slide switch SW1 on the underside and set to the correct position. Carefully position the circuit board and snap the case together again.

For Example

Say you have 4 load cell, 500kg capacity, 3mV/V and you want the PT100LC to output 20mA with 600kg load.

$$\text{Output} = 600 / 4 / 500 * 3 = 0.9 \text{ mV.}$$

The sensitivity switch setting would be the 1.5mV range as the maximum input expected is less than 1.5mV.



API 12.369 PT100LC Installation

Product Support.

• Output configuration.

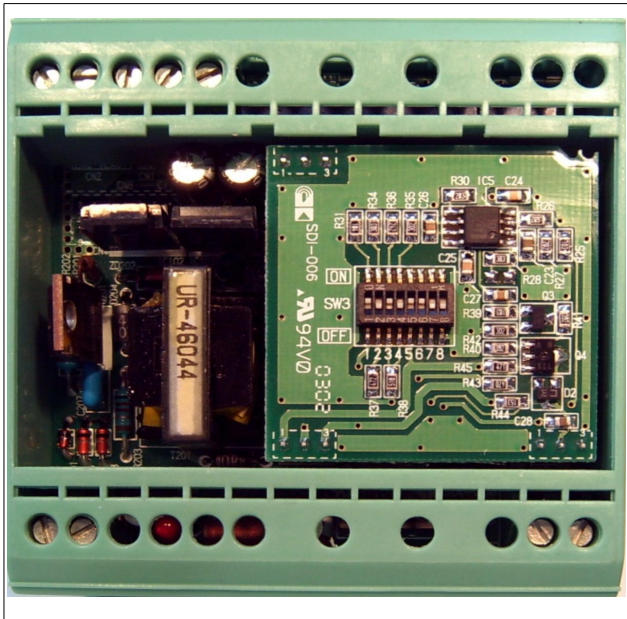

The PT100LC can be set to 3 output formats with SW3. Remove the clear plastic cover and set the DIP switch SW3 with a small screw driver as per the following table.

Output Format	SW3 position							
	1	2	3	4	5	6	7	8
DC 0~20 mA	OFF	OFF	OFF	ON	ON	ON	OFF	OFF
DC 4~20 mA	ON	OFF	ON	OFF	ON	ON	OFF	OFF
DC 0~10 V	OFF	ON	OFF	OFF	OFF	OFF	ON	ON

Installation

Install the PT100LC by snapping in place on a section of electrical DIN rail. Connect the load cells, the output and lastly the power supply.

Calibration

It is suggested that calibration be performed with a multimeter attached to the output so that the calibration can be observed and checked before connection to further instrumentation.

- Zero adjustment.

Remove all load on the weighing device(hopper or scale). Adjust the coarse and fine zero trimmers to obtain the desired empty output signal (0V, 0 or 4 mA) as measured at the output terminals. Note that turning the coarse ZERO trim pot clockwise increases the output voltage.

- Span adjustment.

Apply a known load to the weighing device and adjust the coarse and fine SPAN trimmers to obtain the desired output signal with that load. For example if the scale weighing range is 2000 kg and output is configured to be 0~20 mA then if 500 kg is placed on the scale the output should be 5 mA. Note that turning the SPAN trim pot clockwise increases the output voltage.

- Repeat.

Check the zero and span and if necessary repeat the above procedure until zero and Span are correct.

Troubleshooting.

At times it is possible to achieve a configuration that makes further adjustment seem to be without effect. It is best to make a few checks and revert to a known starting point.

- Check connections and measure the 24V supply voltage and load cell excitation voltage is 10V.
- Measure the input voltage from the load cells with only the empty vessel weight. This should be between 0 and 20 mV. If not then check the load cell system for faults or excessive dead load.
- Check the switch settings are correct.
- Wind the SPAN coarse trim pot fully counter clockwise. This will keep turning past the end point which can be determined by a quiet clicking.
- Connect (short) the input signal + and signal - (not the excitation) to simulate zero input. Adjust the ZERO trim pot to get zero output. CW if the reading is -ve, CCW if +ve.
- Remove the shorting link and re-adjust the ZERO and SPAN trim pots as in calibration above.

Specifications

Power Supply : 24 V DC or AC +/- 10%

Power Consumption : 5.2 VA (max)

Load Cell Type : All Strain Gauge Types.

Input Sensitivity : 1.5 or 3.5 mV/V full scale

Output : 0~10 V (load resistance > 4k ohm)

: 4~20 mA (load resistance < 550 ohm)

: 0~20 mA (load resistance < 550 ohm)

Non-linearity : Within 0.05% of full scale

Zero Adjustment : 0~80 %, coarse and fine, maximum nullification 20 mV

Dimensions : 75 mm x 75 mm x 55 mm (H)

Operating Temp. : -5 Deg. C to 60 Deg. C

Relative Humidity : 90 % non-condensing

Load Cell Supply : 10 V DC

Span Adjustment : 100~20 %, coarse and fine.

Weight : 150 g (Approximate)