

DATE	E.C.O. REVISIONS
JAN 26/82	ADDED 5.0 MAX
FEB 9/82	ADDED KEYHOLE LOCATION, PANEL 0.5-1.8 WAS 0.5-1.0 REVERSED FROM FORM REVISED PART DIMENSIONS TO NEW HAND MADE SAMPLES
APR 16/82	19.6/18.6 WAS 20.2/19.2, 9.9/8.8 WAS 9.25/8.00
MAY 26/82	1.8/1.3 WAS 2.6/2.2
DEC 23/82	
DEC 5/86	R.76 WAS R.03
02/26/93	*1356 1.0 MAX WAS 1.0/.5, 1.0 WAS .76 MAX, RC44-51 WAS C42-50, .5 MAX ADDED, REDRAWN ON CAD

D98332-071M

D98332-071M

NONCONTROLLED COPY

ACTUAL SIZE

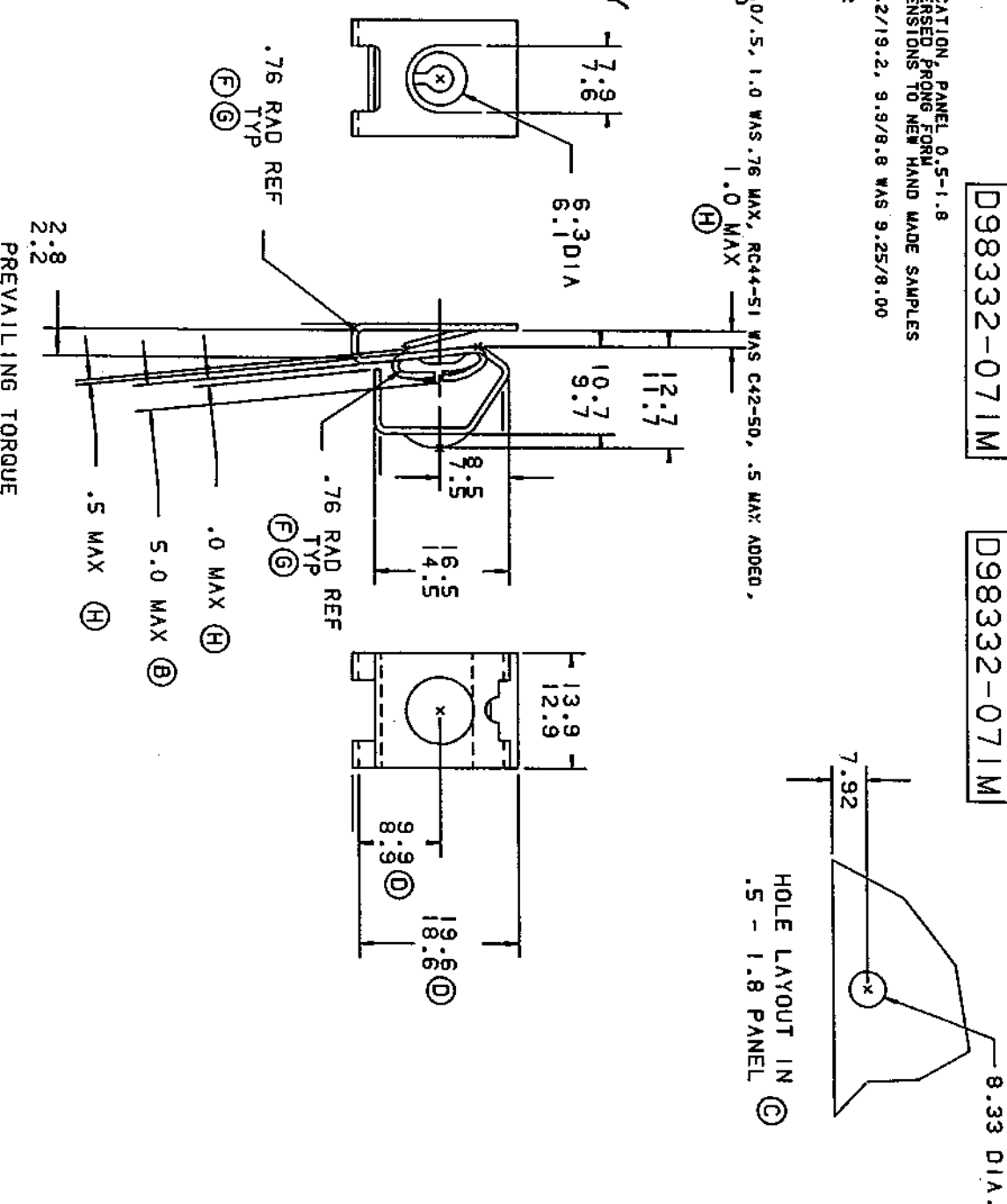
NOTE: "D" IDENTIFICATION TO APPEAR ON FACE OF PART.

MATERIAL SAE 1050-1065	SCALE 2:1	DRAWN P. Solvey	CHECKED <i>[Signature]</i>	APPROVED <i>[Signature]</i>
	CLASS OF FIT	DATE 02/26/93	RELEASED <i>[Signature]</i>	IST. PROD. 7-16-93
THICKNESS .71	HEAT TREAT AUSTEMPER	NET WT/1000	FINISH HARDNESS: Rc44-51	SPECIAL FEATURES 4.2 X 1.41 TAPPING SCREW

D98332-071M