

REVISIONS

E.C.O	REV	DESCRIPTION	DATE	DR	CK	APP
2398	A	"D" WAS "D"	10/22/98	JW	RR	HR
	B	EMBOSS WAS ADDED	12/2/98	JW	HR	HR
		GUSSET WAS REMOVED				
		5.3/4.7 WAS 6.3/5.7				
2428	C	6.3/5.7 WAS 5.3/4.7	12/24/98	JW	RR	HR
		REV REMOVED				

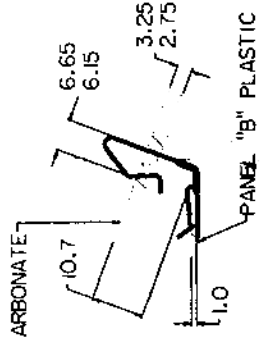

TYPICAL ASSEMBLY
SCALE: 1:1

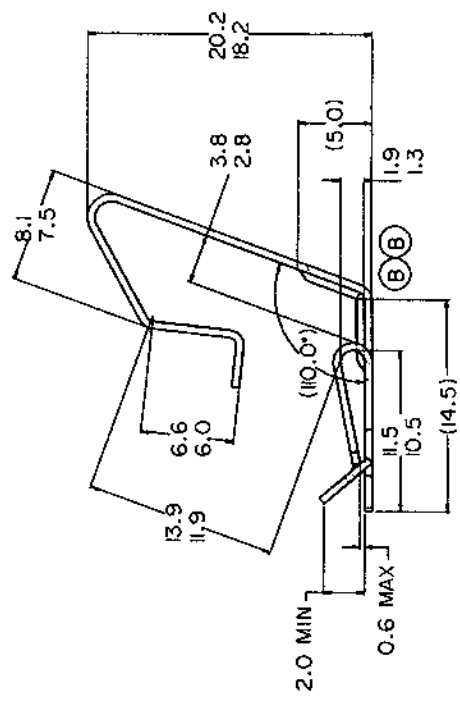
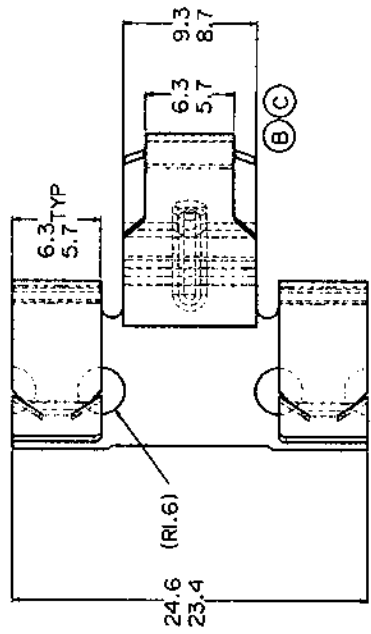

PANEL "A" PERFORMANCE SPECIFICATIONS

INSTALLATION FORCE MAX.	TBD	TBD
RETENTION FORCE MIN	TBD	TBD

SEE EATON SPECIFICATION T98899 FOR TEST PROCEDURES

NOTE: IDENTIFICATION TO APPEAR ON FACE OF PART. DIMENSIONING AND TOLERANCING PER AMSE Y14.5M.



ACTUAL SIZE

MARK TOOL.

TINNERMAN PALNUT
ENGINEERED PRODUCTS, LLC

DRAWN BY	DATE	CHECKED	SCALE	APPROVED
J. WILSON	10/19/98	R. RANKIN RELEASED	3:1	H. RATTMANN 1ST. PRD.
		10/19/98		10/19/98

MATERIAL	THICKNESS	HEAT TREAT	FINISH HARDNESS
SAE 1050-1065	0.51	AUSTEMPER	Rc44-51

NAME: TRIM CLIP PRODUCT CODE #: 930

SPECIAL FEATURES:

SHEET 1 OF 1	DWG NO	D98910-051M ©	SIZE
			B