

REVISIONS

E. C. O	REY	DESCRIPTION	DATE	DR	CK	APP
1599	A	5.2/4.2 WAS ADDED	09/19/94	MB	RR	HR
	A	VIEW ADDED				
	A	NIPPLE WAS MODIFIED				
1605	B	5.2/4.2 WAS REMOVED	09/28/94	MB	RR	HR
	B	3.6/3.1 WAS ADDED				
	B	Ø 4.6 REF. WAS ADDED				
	B	2.0/1.2 WAS ADDED				
	B	1.7/.9 WAS ADDED				
1640	C	8.9/8.1 WAS 6.7/5.9	12/16/94	MB	MD	RR
	C	5.8/5.0 WAS ADDED				
	C	1.7/.9 WAS DELETED				
	C	11.0/9.0 WAS 12/11				
	C	4.6/3.6 WAS 5.8/5.0				
	C	(1.3) WAS 2.0/1.3				
2020	D	3.55/3.05 WAS 3.6/3.1	01/20/97	JP	RR	

NONCONTROLLED COPY



DRAWN BY	DATE	CHECKED	SCALE	APPROVED
M. DANBY	05/12/94	ROB RANKIN RELEASED 05/19/94	3:1	H. RATHMANN REV. PROD 05/19/94

MATERIAL	THICKNESS	HEAT TREAT	FINISH	HARDNESS
SAE 1050-1065	0.71	AUSTEMPER	Rc44-51	

NAME	PRODUCT CODE #
SPECIAL SHAPE CLIP	866

SPECIAL FEATURES:	SIZE
SHEET 1 OF 1	D98754-071M
DWG NO	B

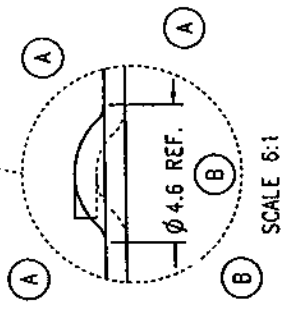
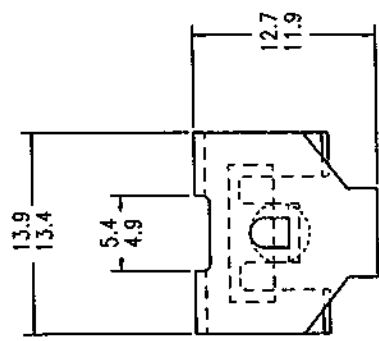
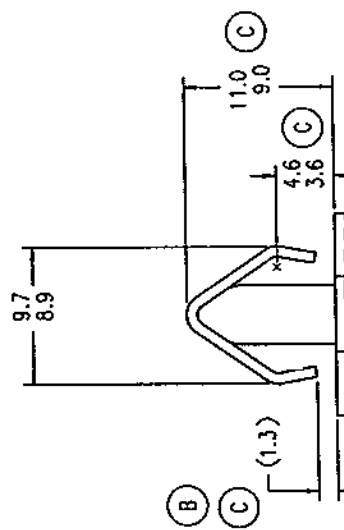
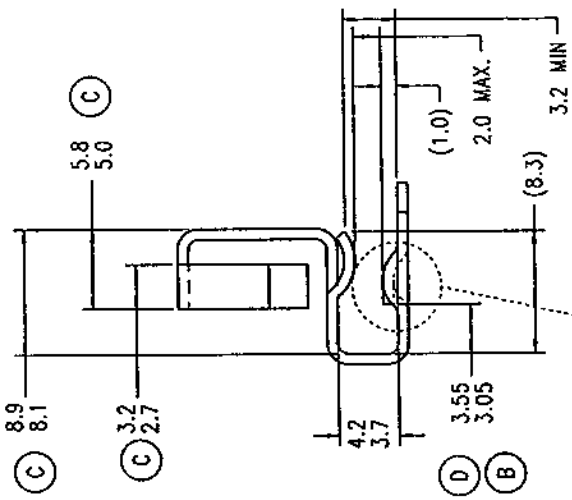
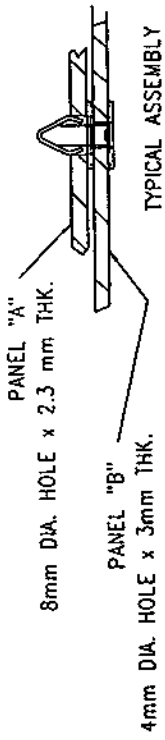

SCALE 5:1



ACTUAL SIZE

NOTE: "D" IDENTIFICATION TO APPEAR ON FACE OF PART. DIMENSIONING AND TOLERANCING PER ANSI Y14.5M.