

TYPICAL ASSEMBLY

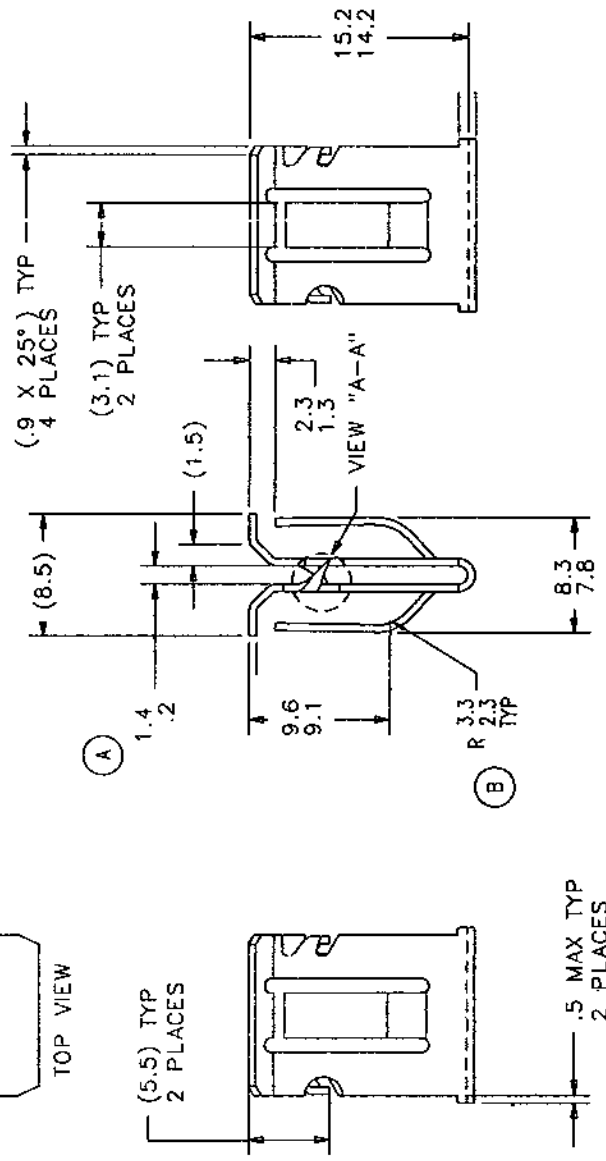
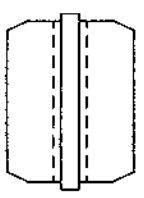

PERFORMANCE SPECS	
MATING PART	RETENTION LBS
"A" PANEL	N.R.
"B" RETENTION TO PNL "B" TO BE GREATER THAN "A"	14 TO 22

E. C. O	REY	DESCRIPTION	DATE	DR	CK	APP
1673	A	1.4/.2 WAS 1.5 MAX	02/07/95	JW	RR	HR
1904	B	PERFORMANCE SPECS ADDED	06/07/96	RG	LL	X
		3.3/2.3 RAD TYP ADDED				

DRAWN BY	DATE	CHECKED	SCALE	APPROVED
P. SELVEY	01/03/95	J. MULDOON RELEASED 01/11/95	3:1	R. RANKIN 1ST. PRD 01/11/95

MATERIAL	THICKNESS	HEAT TREAT	FINISH HARDNESS
SAE 1050-1085	0.51	AUSTEMPER	Rc44-51

SPECIAL FEATURES:	
NAME	TRIM CLIP
PRODUCT CODE #	930

SHEET 1	DWG NO	SIZE
OF 1	D98786-051M	B

NONCONTROLLED COPY



NOTE: IDENTIFICATION TO APPEAR ON FACE OF PART. DIMENSIONING AND TOLERANCING PER ANSI Y14.5M.