

New harder grade
Min. Hv0.3 610
Tested to ISO 898

K-SERIES
Setzmutter

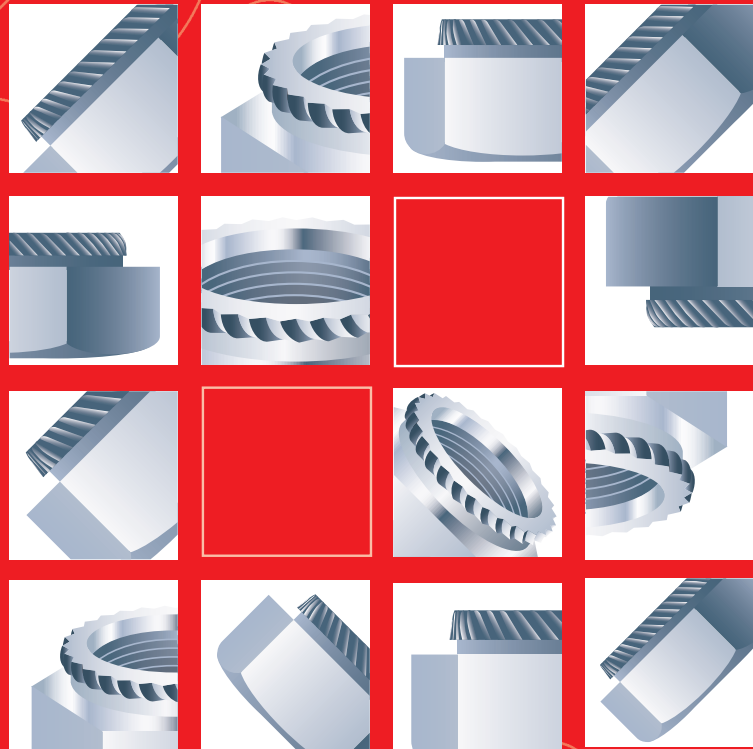

Lancaster Fastener Co Ltd
Threadforming Screw Specialists



K-SERIES Setzmutter

Zinc & Clear (CR3)

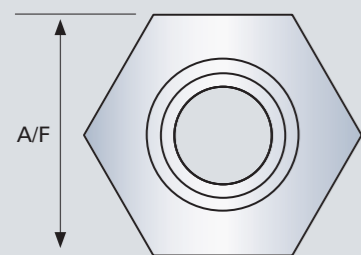
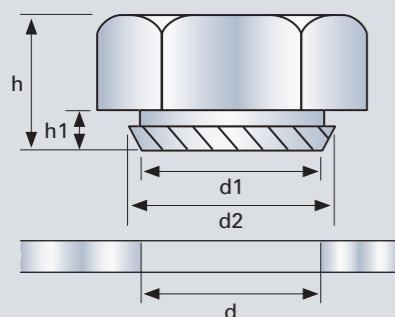
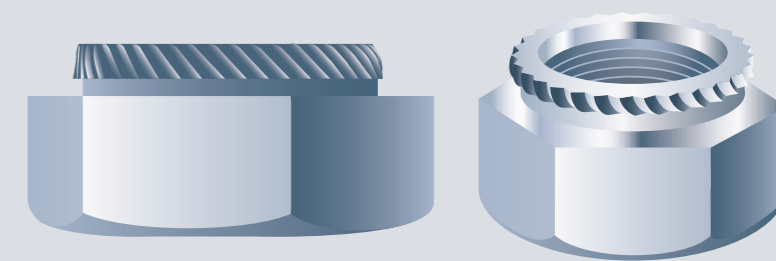

Size	Material Thickness	Across Flats A/F in mm	Hole Diameter d Ø in mm	d1 Ø in mm	d2 Ø in mm	Spigot Length		K-Series Setzmutter Product Code	Kalei® Setzmutter Product Code	
						h in mm	h 1 in mm			
M 2.5	1 mm	5.50	4.50	4.50	4.70	3.00	0.90	KPN02510STZC	700003053	Standard Spigot Ex-Stock
M 3	1 mm	5.50	4.50	4.50	4.70	3.00	0.90	KPN03010STZC	700003004	
M 4	1 mm	7.00	5.50	5.50	5.70	3.20	0.90	KPN04010STZC	700003005	
M 5	1 mm	8.00	6.50	6.50	6.75	4.00	0.90	KPN05010STZC	700003006	
M 6	1 mm	10.00	8.00	8.00	8.30	5.00	0.90	KPN06010STZC	700003007	
M 8	2 mm	13.00	10.00	10.00	10.30	6.50	1.80	KPN08020STZC	700003008	
M 10	2 mm	15.00	12.50	12.50	12.85	8.00	1.80	KPN10020STZC	700003009	Intermediate Spigot Ex-Stock
M 12	3 mm	17.00	14.50	14.50	14.85	10.00	2.80	KPN12030STZC	700003010	
M 16	3 mm	22.00	18.50	18.50	18.85	13.00	2.40	KPN16030STZC	700003011	
M 20	4 mm	27.00	23.00	23.00	23.40	16.00	3.90	KPN20040STZC	700003012	
M 2.5	1.5 mm	5.50	4.50	4.50	4.70	3.00	1.40	KPN02515STZC	700003180	
M 3	1.5 mm	5.50	4.50	4.50	4.70	3.00	1.40	KPN03015STZC	700003181	
M 4	1.5 mm	7.00	5.50	5.50	5.70	3.20	1.40	KPN04015STZC	700003182	Long Spigot Ex-Stock
M 5	1.5 mm	8.00	6.50	6.50	6.75	4.00	1.40	KPN05015STZC	700003183	
M 6	1.5 mm	10.00	8.00	8.00	8.30	5.00	1.40	KPN06015STZC	700003268	
M 2.5	2 mm	5.50	4.50	4.50	4.70	3.00	1.80	KPN02520STZC	700003280	
M 3	2 mm	5.50	4.50	4.50	4.70	3.00	1.80	KPN03020STZC	700003035	
M 4	2 mm	7.00	5.50	5.50	5.70	4.50	1.80	KPN04020STZC	700003056	
M 5	2 mm	8.00	6.50	6.50	6.75	5.00	1.80	KPN05020STZC	700003038	
M 6	2 mm	10.00	8.00	8.00	8.30	5.00	1.80	KPN06020STZC	700003040	

About the product

K-Series Setzmuttern offer a permanent female thread in sheet steel and in some plastic applications that are too thin to be tapped by conventional methods.

Designed specifically for use in applications with a minimum sheet thickness of 1mm, K-Series Setzmuttern when installed offer a metric female thread for attaching equivalent metric externally threaded fasteners.

K-Series Setzmuttern can be easily installed into the parent material without the need for specialist tooling. When inserted the underhead shank serrations of the Setzmuttern provide a permanent thread with a high prevailing torque and a resistance to turning.

Available ex-stock, we offer K-Series Setzmuttern in all of the standard spigot lengths. We now also offer intermediate and long spigot lengths ex-stock for use in thicker sheet steel or plastic applications. All stocked sizes are available in Zinc Plated (CR3), carbon steel. Stainless steel finishes can be supplied to order.

Product features

- ☆ A small range of sizes to suit most applications.
- ☆ M2.5 - M20 sizes ex-stock.
- ☆ No special tooling required.
- ☆ One head style - Hexagon.
- ☆ Three spigot lengths available ex-stock: **Standard, Intermediate & Long.**
- ☆ High torsional resistance.
- ☆ High pullout resistance.
- ☆ Zinc Plated (CR3) as standard.
- ☆ Stainless Steel supplied to order.
- ☆ Stock ready for immediate despatch. 3-4 day delivery to most European Countries.

New harder grade

- ☆ **Material: C1022 Carbon Steel.**
- ☆ **Case Hardened to a minimum of Hv0.3 610**
- ☆ **Tested to ISO 898.**

Product installation

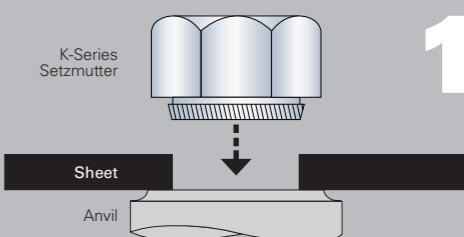

Prior to installation the K-Series Setzmutter must be aligned squarely with the pre-drilled or pre-pressed hole in the host material.

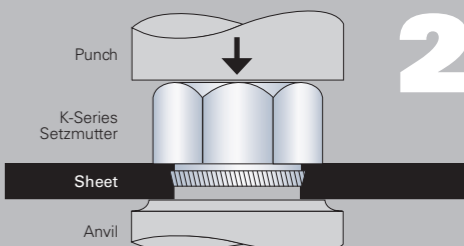

Ideally using a punch the K-Series Setzmutter is pressed into the host material. As the nut rotates it bites into the wall of the sheet causing the host material to flow around the spigot of the nut. The slanted serrations provide a secure fit with a strong resistance to rotation.

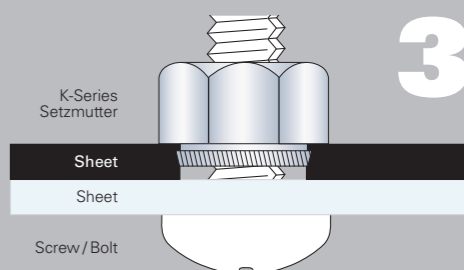

When the K-Series Setzmutter has been installed an externally threaded fastener can be used to join the two materials together. The K-Series Setzmutter is secured from the serrated side.

Additional copies of this brochure can be requested from our sales team.

Alternatively, view/download this brochure from our website.

lancasterfastener.co.uk/k-series



Diese Broschüre ist auch auf Deutsch erhältlich. Kontaktieren Sie unser Verkaufsteam, um ein Exemplar anzufordern.

Als Alternative steht auf unserer Webseite eine deutsche Version zum Download zur Verfügung.

lancasterfastener.co.uk/german/k-series

K-Series is a product name used by Lancaster Fastener Co Ltd.
Kalei® is the registered trade mark of DVSG Maschinen & Service AG.



Lancaster Fastener Co Ltd

Threadforming Screw Specialists

Middlegate, White Lund Industrial Estate, Morecambe, England LA3 3BN
Tel: +44 (0)1524 62645 Fax: +44 (0)1524 66367
Website: www.lancasterfastener.co.uk Email: enquiries@lancasterfastener.co.uk



CERT No. R528449 BS EN ISO 9001:2008

A
TRIFAST PLC GROUP
COMPANY



INVESTOR IN PEOPLE