

PANEL THICKNESS: 2.8  
TYPICAL ASSEMBLY  
SCALE: 1:1

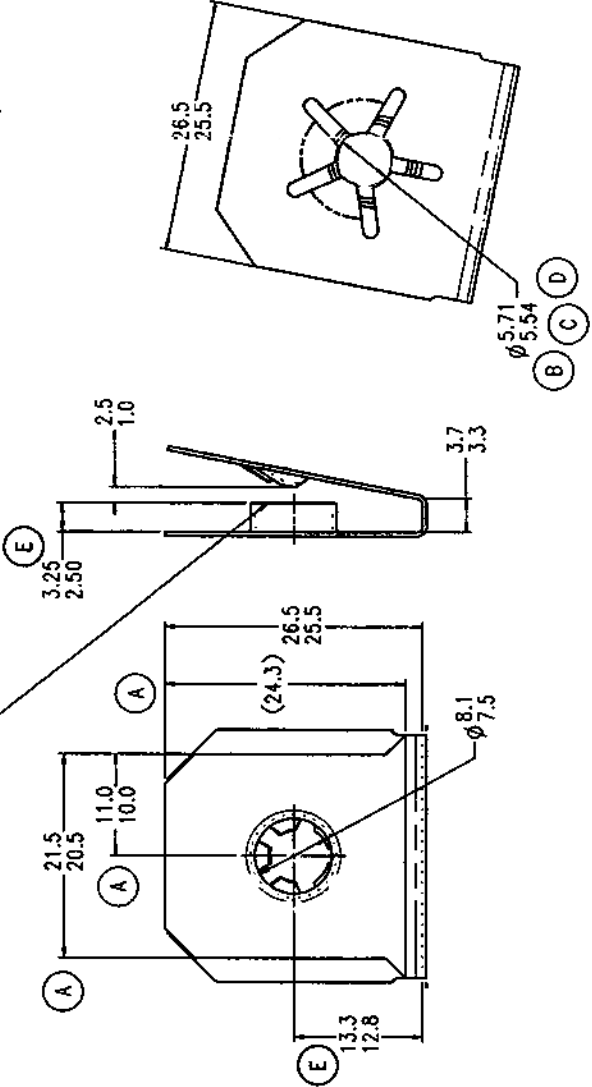

REVISIONS

E.C. OR REV	DESCRIPTION	DATE	DR	CK	APP
1950 A	(24.3) ADDED	10/02/96	JP	RR	HR
	21.5/20.5 WAS 25.5/24.5				
	11.0/10.0 WAS 13.0/12.0				
2158 B	Ø 5.9/5.5 WAS Ø 5.8/5.4	09/18/97	RG	RR	HR
2566 C	Ø 5.7/5.5 WAS Ø 5.9/5.5	11/23/99	MZ	RR	HR
	REDRAWN ON NEW BORDER				
2578 D	Ø 5.71/5.54 WAS Ø 5.7/5.5	11/26/99	MZ		
2725 E	13.3/12.8 WAS 13.5/12.5	10/17/00	YJ	Ø	Ø
	3.25/2.50 WAS 3.5/2.5				

MARK TOOL:



DRAWN BY	DATE	CHECKED	SCALE	APPROVED
J. WILSON	06/04/96	R. RANKIN RELEASED	2:1	H. RATTMANN EST. PRG.
		06/06/96		06/11/96

MATERIAL	THICKNESS	HEAT TREAT	FINISH	HARDNESS
SAE 1050-1065	0.43	AUSTEMPER		Rc44-51
NAME: U TYPE SPEED NUT				PRODUCT CODE #: 735

SPECIAL FEATURES: M6 x 1.00 SCREW

SHEET: 1	DWG NO: D98839-043M	SIZE: B
OF: 1		

NOTE: "D" IDENTIFICATION TO APPEAR  
ON FACE OF PART.  
DIMENSIONING AND TOLERANCING  
PER ANSI Y14.5M.

ACTUAL SIZE