

DATE ECO. REVISIONS

C 1 3 0 3 - M 6 1

CLASSIFICATION OF DIMENSIONS

* DENOTES MAJOR DIMENSIONS

ALL OTHERS-MINOR DIMENSIONS

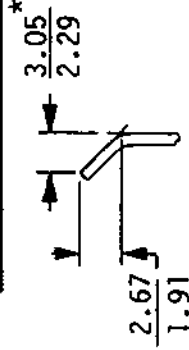

8.71 DIA. HOLE MIN.

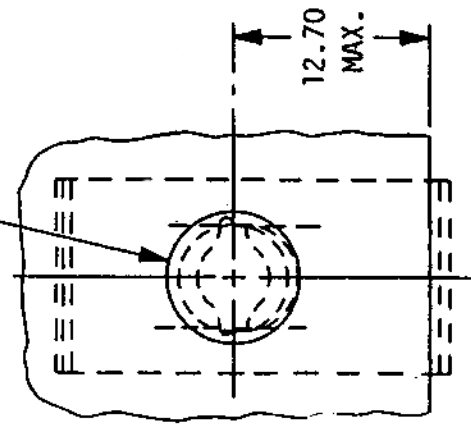

RECOMMENDED HOLE LAYOUT IN 1.63/3.18 PANEL

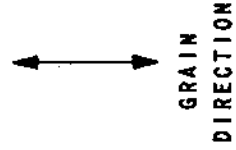
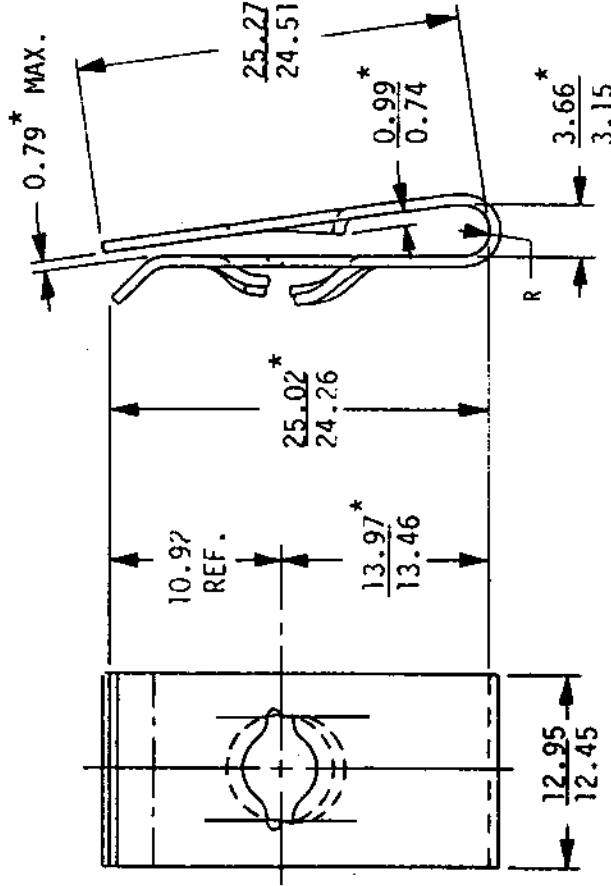
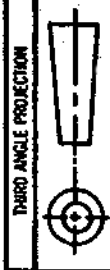

NOTE: UNLESS OTHERWISE SPECIFIED, ALL DIMENSIONS IN MILLIMETERS

NOTE: "T" & M61 IDENTIFICATION STAMPS TO APPEAR ON FACE OF PART

ACTUAL SIZE	SCALE	DRAWN	CHECKED	APPROVED
	2/1	W. / .	J. D.	1 ST. PROD.
MATERIAL	CLASSOFFIT	SPECIAL FEATURES		
SAE 1050-1065 STEEL	FREE	M6 - 1 METRIC	C 1 3 0 3 - M 6 1	
THICKNESS	FINISH ROCK:	MACHINE SCREW	SPEED NUT - "U" TYPE	
.025	45-50C			
	HEAT TREAT	AUSTEMPER		

P.O. Box 10 Brunswick, OH 44212

