

Materials

Tools

- Allen wrench
- Hammer
- Rubber mallet
- Flat head screwdriver

Note: This is a discontinued product. Available stock is limited and for matching existing only.

Index

- 1 Introduction to basic panel components and alignment plate installation
- 2 Panel cleaning procedures
- 3 Angled panel assembly
- 5 Straight panel assembly
- 6 Replacing a panel in a row of panels
- 7 Directions for a high low panel arrangement
- 8 Additional panel arrangements (including X, Y, T, and T-1)
- 11 Replacement of a panel in a “Y”, “X”, “T” or “T-1” arrangement
- 12 Knock-out Removal

General Notes

- Do not store different size panels against a wall or stack one on top of each other. Panels are to be stored in an upright position where the edges are lined up.
- When installing a Series 9000 structural panel system it is suggested that you start from an angled “Y”, “X”, “T”, OR “T-1” arrangement.
- A stabilizer foot is not used to support a panel with a overhung load, it is only used to support a panel run.
- Every right angle panel connection supporting an overhung load should have an alignment plate installed. Each panel is shipped with 2 end covers attached to one end of panel. You will have 1 end cover and hinge assembly remaining after installing a panel work station. Remove hinges and install end covers on panels at the “open” end. The extra end cover will also be needed at a transition from high to low.
- To remove top trim, hold with two hands, one at each end and pull straight up. Refer to Fig A.
- To attach top trim, align one end and engage top trim into end spring clip with a downward motion. Repeat at all spring clips. Be sure the top corners of both inner uprights are covered by centering top trim.
- If you find it necessary to remove base trim, pull out from bottom edge. Refer to Fig. B.
- Glass panel installation recommendations:
 - One panel or 4 feet can be run off angularly from a wall attachment or other panel without additional support.
 - Two panels or 8 feet can be run off angularly from a wall attachment or other panel if stabilized at least by support feet on both sides of the end panel.
 - Not more then three panels or 12 feet should be in a straight run. In this condition both ends should be stabilized by either wall attachment or panel at an angular condition.
 - Hang on loads resulting in overhung loads are not recommended.
- Level panels as they are individually attached. To do this adjust the glide so adjacent uprights are level.
- Make sure slot cover is free of top tabs. Pull out if necessary.

General Notes (continued)

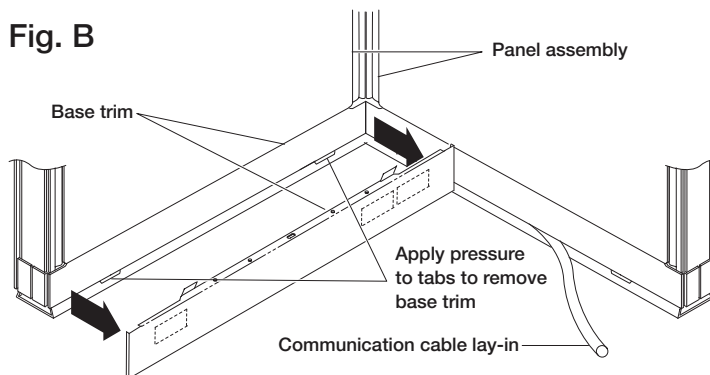
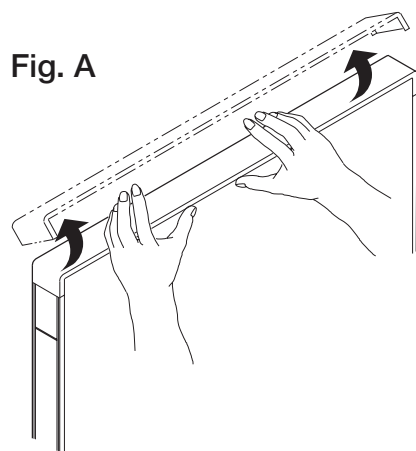

- When installing panel on high pile carpet the glides must be extended to facilitate communication cable lay-in.
- The original panel system manufactured before 08/79 and the revised panel system manufactured after 08/79 can be connected to each other by using the revised hinge. The revised hinge must be shortened 5/16" on top to fit the original end cover.
- As of January 1996, plain and power base trims are combined into a single combination base trim. The base trim will include "Knock-out" receptacle openings in place of closure plates, (See Page 14.)

Stain Treatment for Panel Fabrics

There are two kinds of stains, water-borne and oil-borne. Coffee, fruit juices and washable ink are examples of water-borne stains. Most foods (mustard, salad dressings, milk) permanent fountain pen ink, ball-point pen ink and hair dressings are typical oil-borne stains. Each type of stain must be treated with different solutions-and promptly. Use Spray Kleen for water-borne stains and any dry cleaning solution for oil-borne stains. Follow these directions:

- 1 Soak up the excess staining material immediately with a soft, absorbent cloth. Do not let stain dry completely or it may set. For most water-borne stains or general cleaning, use normal solution of one cap of Spray Kleen to one applicator of water (16oz.) For heavier soil or water-borne stains use a solution of one (1) part of Spray Kleen to four (4) parts of water.
- 2 For oil-borne stains use dry cleaning solution for fabric and stain. Cleaning agent should be room temperature. For oil-borne stains use dry cleaning solution. Cleaning agent should be room temperature. Allow solution to work into stain.
- 3 Using quick light strokes, brush the stain with a soft bristle brush. (Work from the outside of stains toward the center to prevent rings). Vigorous rubbing is not recommended, as it may injure the nap or force the stain deeper into the material.
- 4 To avoid leaving a dirt attached residue, soak up remaining cleaning solvent on oil-borne stains, use a cool water rinse (which will also help prevent rings) on water-borne stains.
- 5 Allow fabric to dry completely, then vacuum thoroughly.
- 6 Repeat cleaning method if stain is still evident. Several light applications have proven to be more effective and less harmful to fabrics than one concentrated treatment.

Cleaning Plexiglass Panels

- 1 Dust with a soft damp cloth or chamois.
- 2 Clean only with mild soap or detergent and water. Rinse well-Dry with a soft damp cloth or chamois.
- 3 Polish by applying a thin even coating of good grade automobile paste wax (not a cleaner-wax combination) with a clean soft cloth. Buff lightly with a clean cotton flannel or jersey cloth.
- 4 Avoid aromatic solvents and abrasives.
- 5 Combustible! Observe fire precautions appropriate for comparable forms of wood. Do not expose to excessive heat or flame.

Angled Panel Assembly

Note: It is suggested that assembly of a run of panels start from one corner. Move two panels into position in accord with office plan.

- 1 Remove top trim. Hold with two hands, one at each end and pull straight up.
- 2 Raise end cover and hinge assembly by backing of socket head screw until assembly moves up approximately 1/2". This disengages cover from inner upright tabs.
- 3 Remove end cover hinge assembly, lifting up and out from panel.
- 4 Hinge preparation for angled panel assembly. The end cover and hinge assembly consist of two end covers and two plastic hinged. Remove one hinge by peeling from end covers starting at bottom of assembly. Hinge may be stored for future need.
- 5 Replace end cover and hinge assembly. Lift end cover and hinge assembly so that all slots intersect with all inner upright tabs. Then exert pressure downward to interlock.

Top View Corner

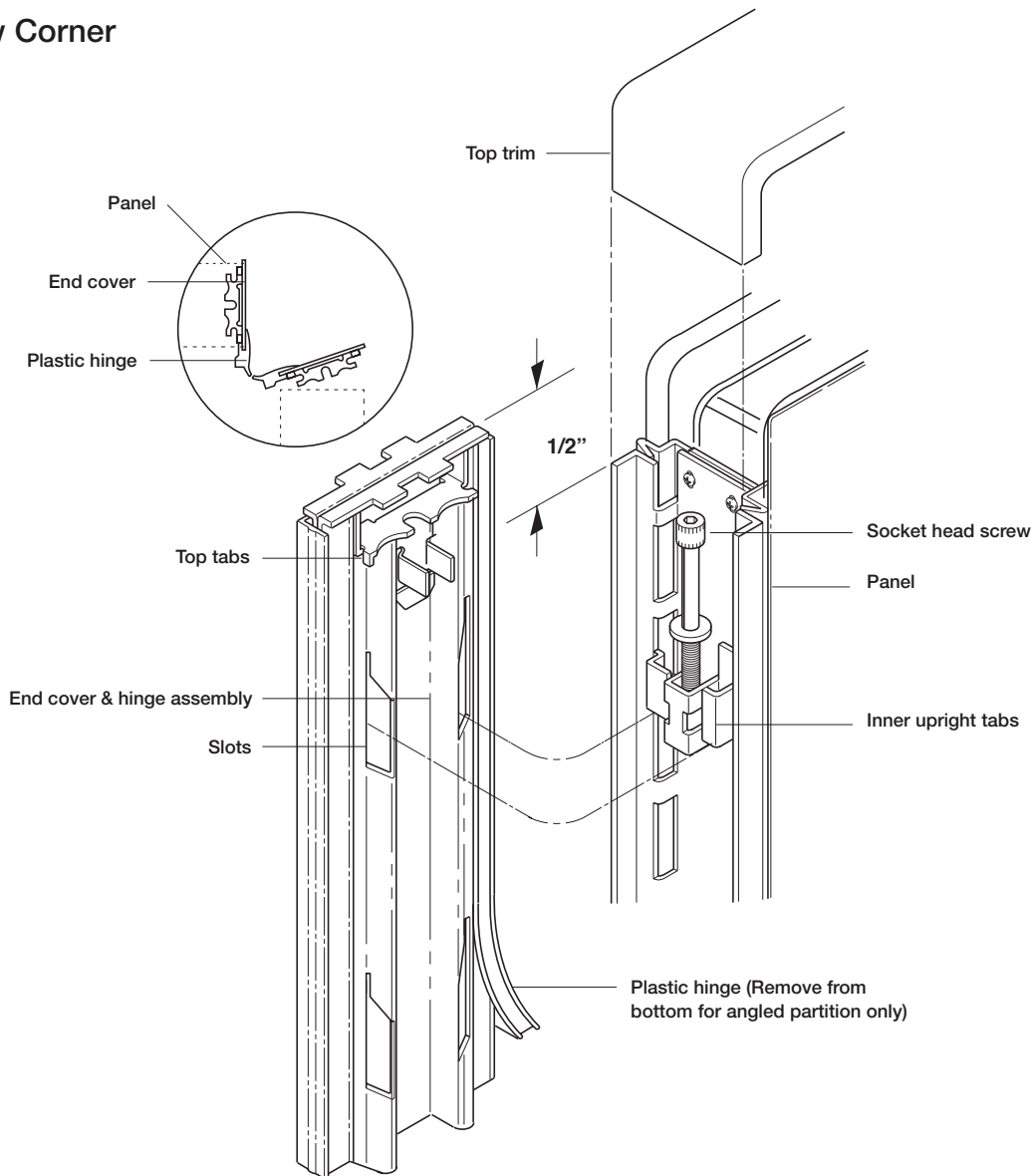

Angled Panel Assembly (continued)

- 6 To complete interlock tighten socket head screw until top of end cover is level with top of upright.
Note: Align top edge of uprights (by eye) by adjustment of glide.
- 7 With end cover and hinge assembly properly prepared and socket head screw in proper position, move panel "A" in direction of arrow. Lift panel so that the slots in the end cover intersect with the inner upright tabs in panel "B" then exert pressure downward to interlock. Make sure slot cover is free of end cover top tabs.
- 8 Repeat step 6.
- 9 Adjust glide making sure uprights on adjacent panels are level.

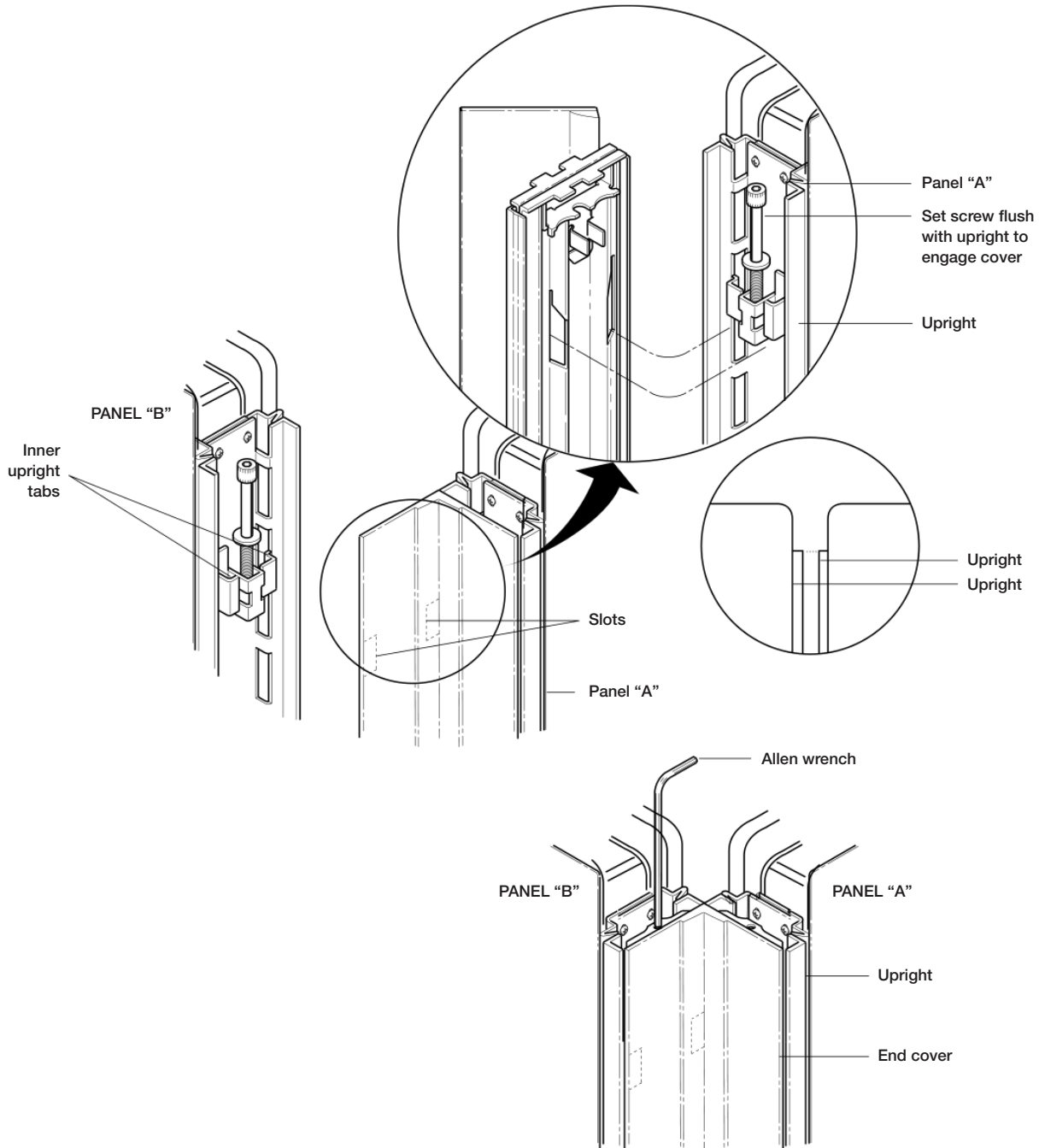

Straight Panel Assembly

Start panel from already assembled angled panels.

1 Remove top trim. Hold with two hands, one at each end and pull straight up. Move panel in line with corner making sure panels are aligned vertically across by adjustment of glide.

2 Pre-adjust socket head screw to proper position. Lift panel "A" in direction of arrow so that all slots in the end cover intersect with all inner upright tabs in panel "B" then exert pressure downward to interlock.

Note: Make sure slot cover is free of top tabs. Pull out if necessary.

3 Repeat step 6 of angled partition assembly.

4 Rough adjust glides to make panels level and to evenly distribute panel weight.

Note: At completion of panel installation replace all top caps. At the end of a panel run insert end cover only (no hinges) into inner-upright and tighten down. Using a level on top cap, adjust glides as required on each panel to provide a level structure with weight evenly distributed on glides.

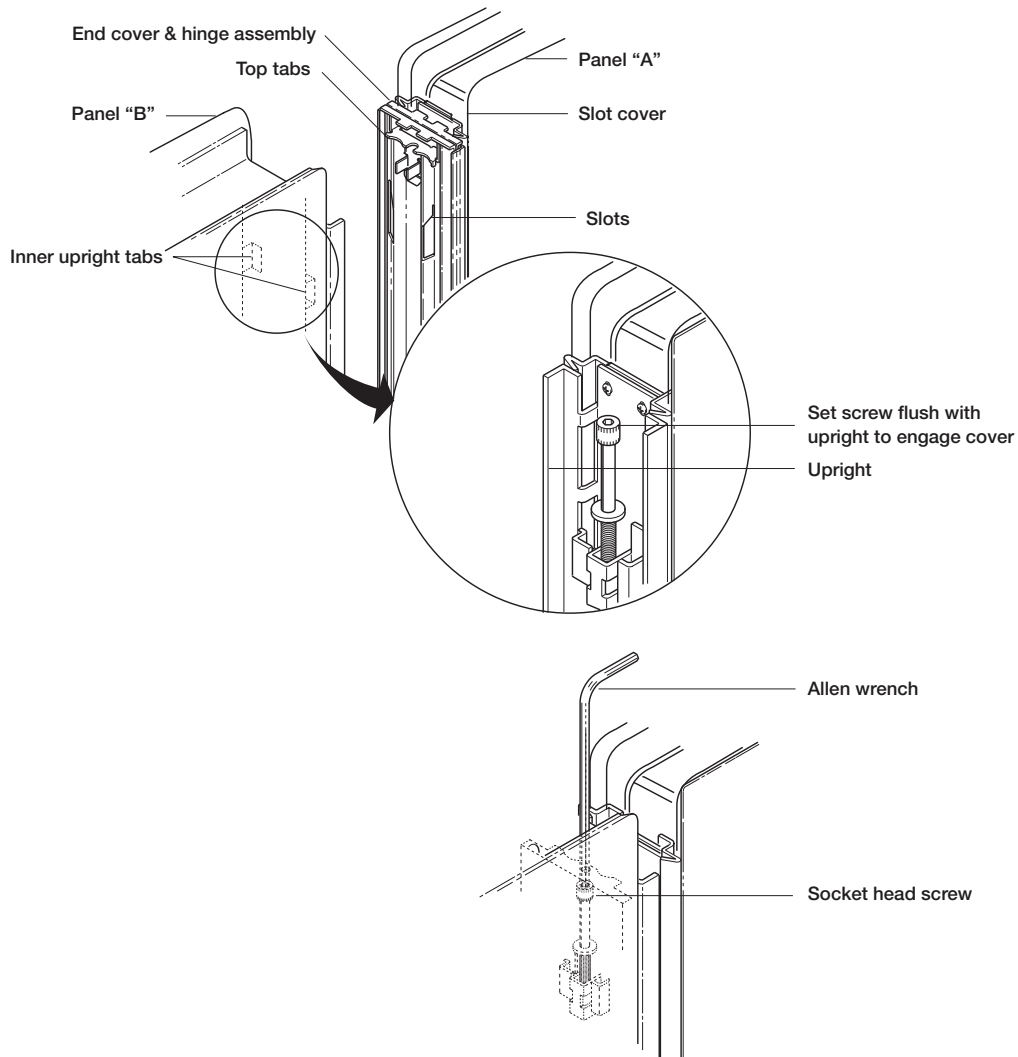

Replacing a Panel in a Row of Panels

- 1 Remove top trim of the panel to be removed and the two adjacent panels by lifting straight up with two hands, one at each end.

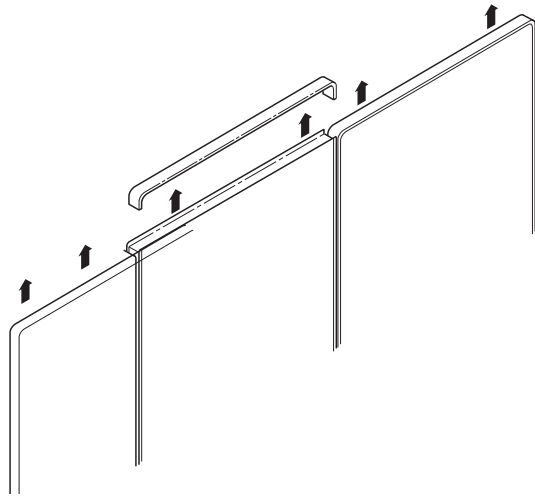

- 2 Alternately loosen (turn) each screw 2 or 3 turns to minimize the turning force. Repeat this step on both screws on panel to be removed and screws affected on adjacent panels. Making a total of four socket head screws to be unscrewed. Raise hinge and end cover assembly to disengage.

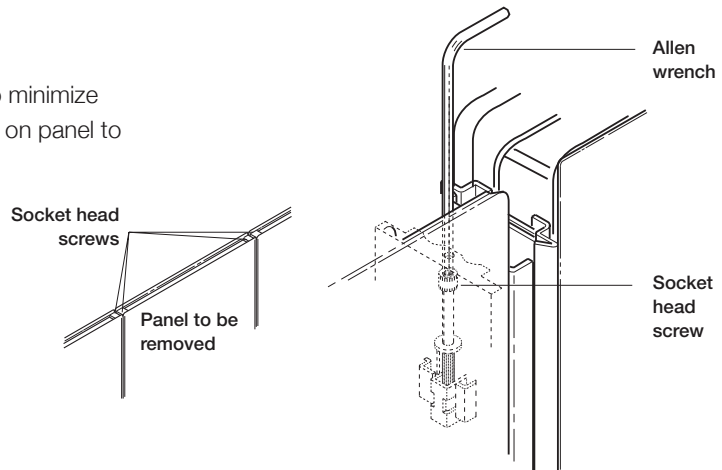

- 3 Work the panels apart by slightly angling the rows of panels. Pull out the end cover and hinge assemblies between the panel and the two adjacent panels. Remove the panel.

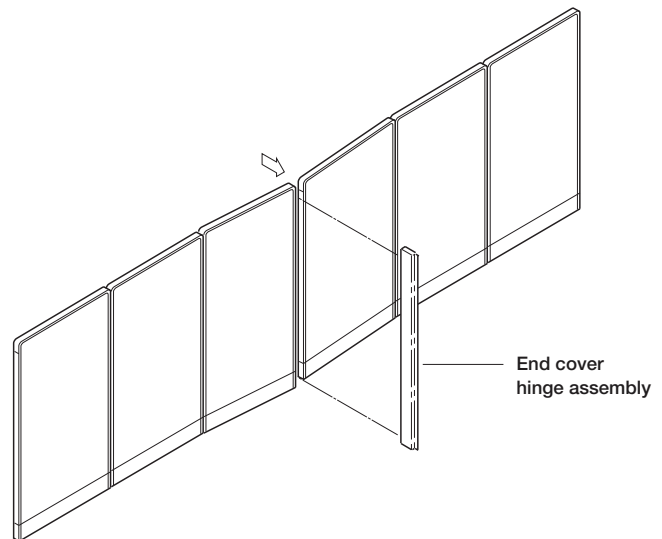

- 4 Repeat above assembly procedure in reverse to make the replacement.

High-Low Panel Arrangement

- 1 Take remaining end cover left from high panel installation and set aside until step 4.
- 2 Remove end cover and hinge assembly from low panel.
- 3 Remove both hinged from low panel end cover.
- 4 Attach hinge(s) to high panel end cover and low panel end cover starting at the top of the low panel end cover.
 Note: Illustration below represents a straight panel assembly in which (2) hinges are used. In the case of an angled panel assembly only (1) hinge is used.
- 5 Replace end cover and hinge assembly to low panel.
- 6 Attach low panel to high panel.

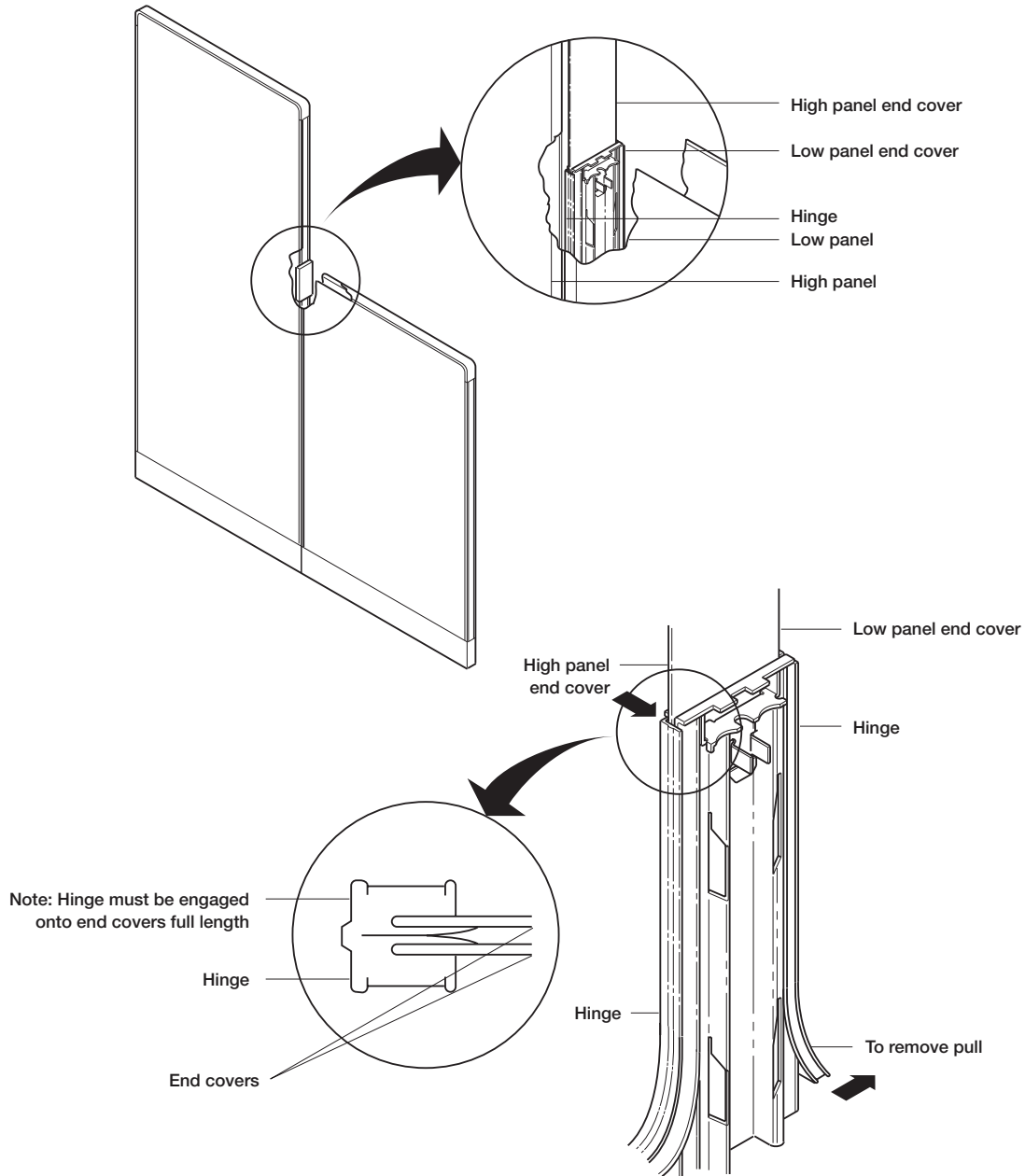

Additional Panel Arrangements

Note: When installing a Series 9000 structural panel system, it is suggested that you start from an angled, “Y”, “X”, “T”, or “T-1” arrangement.

Directions for a “Y” arrangement:

- 1 Three panels are needed for a “Y” arrangement. Remove the end cover and hinge assembly from each panel. Remove one hinge from one of the end cover and hinge assemblies, this will give you an angled hinge preparation. Take a single end cover and two hinges and assemble to the angled hinge preparation, leaving the single end cover 1/2” higher than the angled hinge preparation.
- 2 Assemble panels “A” and “B” according to angled panel assembly.
- 3 Move panel “C” in direction of arrow until the slots and inner upright tabs intersect. Make sure slot cover is free of top tabs, then tighten socket head screw until top of end cover is level with top of upright.

Note: If hinges are too stiff and the high end cover does not easily slide down to engage with the inner upright tabs, alternate turning the socket head screw down and lightly tapping the top of the end cover using a rubber mallet and screwdriver.

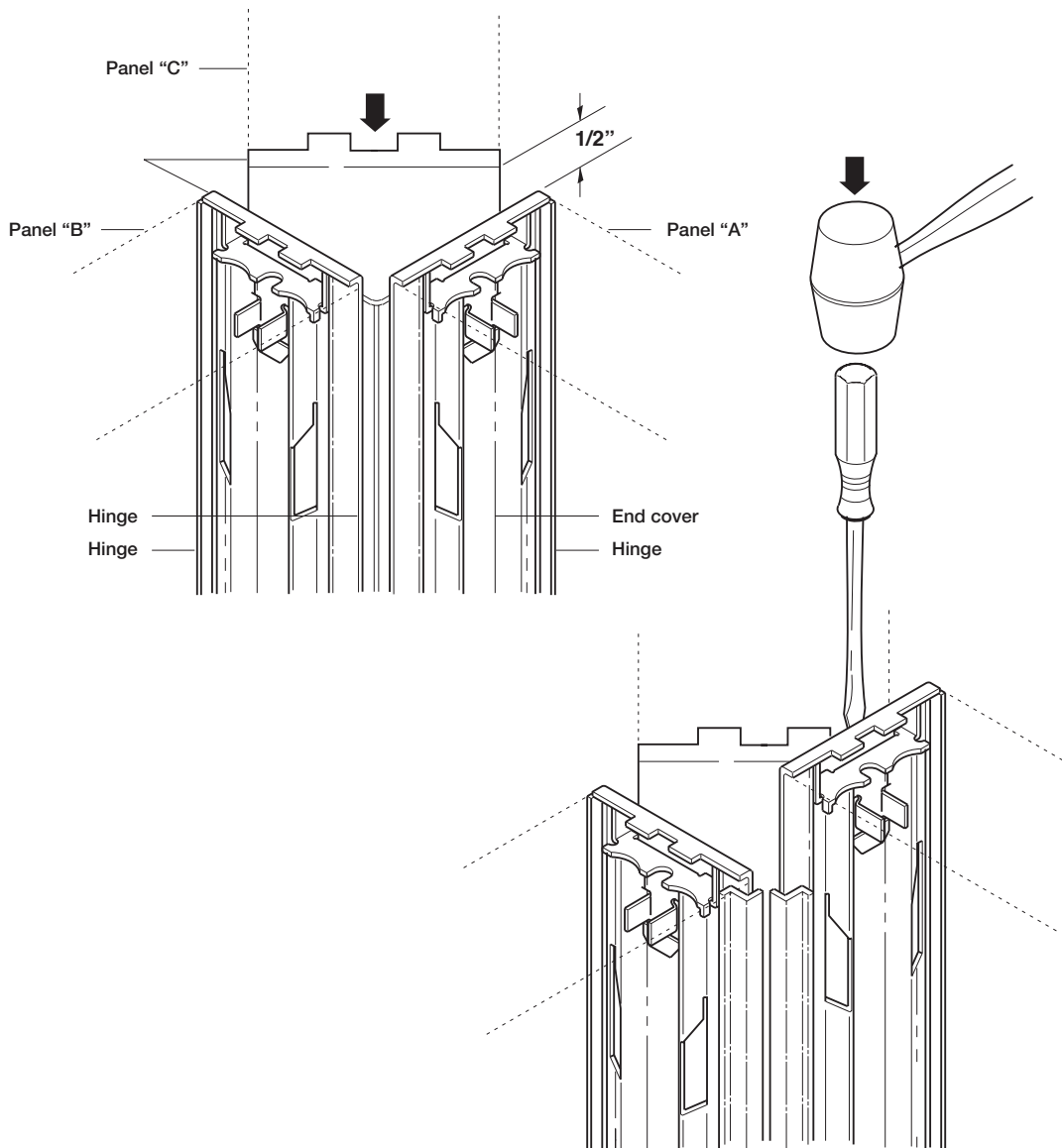

Additional Panel Arrangements (continued)

Directions for a “T” arrangement:

- 1 Three panels are needed for a “T” arrangement. Remove the end cover and hinge assembly from each panel. Remove one hinge from one of the end cover and hinge assemblies, this will give you an angled hinge preparation. Take a single end cover and two hinges and assemble to the angled hinge preparation, leaving the single end cover 1/2” higher than the angled hinge preparation.
- 2 Assemble panels “A” and “B” according to angled panel assembly.
- 3 Move panel “C” in direction of arrow until the slots and inner upright tabs intersect. Make sure slot cover is free of top tabs, then tighten socket head screw until top of end cover is level with top of upright.

Note: If hinges are too stiff and the high end cover does not easily slide down to engage with the inner upright tabs, alternate turning the socket head screw down and lightly tapping the top of the end cover using a rubber mallet and screwdriver.

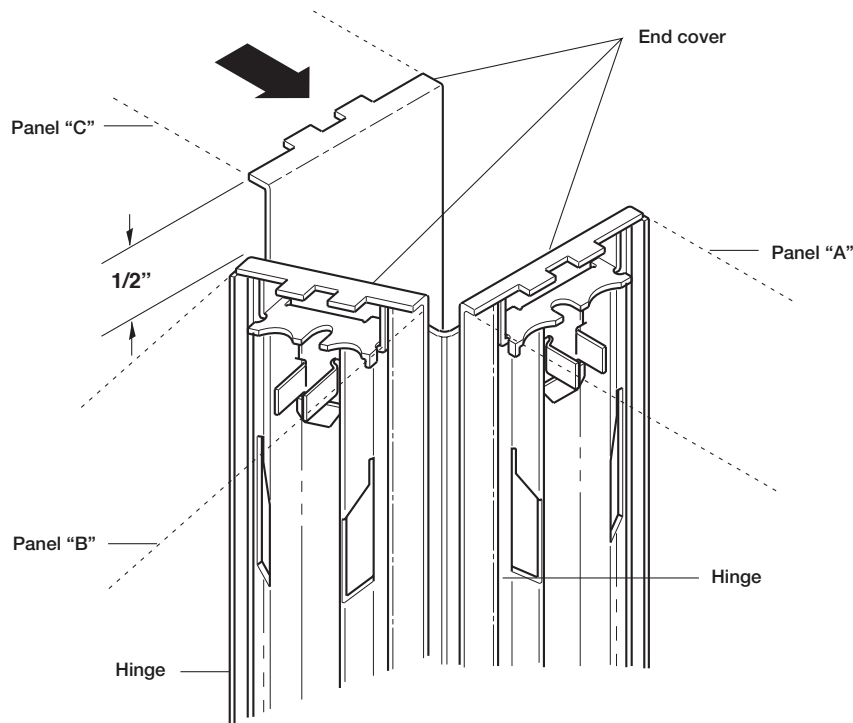

Directions for a “T-1” arrangement:

Assembly is the same as for a “T” arrangement except panel “C” is moved in direction of arrow.

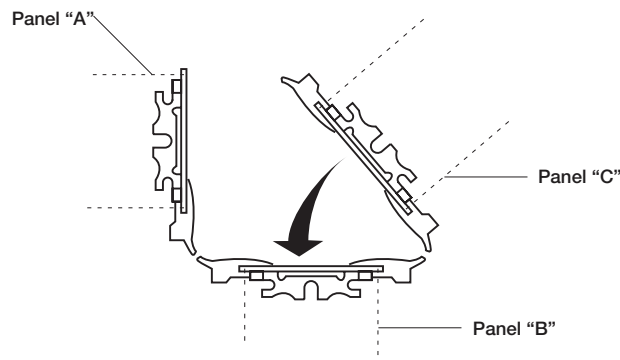

Additional Panel Arrangements (continued)

Directions for a “X” arrangement:

- 1 Four panels are needed for a “X” arrangement. Remove the end cover and hinge assembly from each panel. Remove one hinge from one of the end cover and hinge assemblies. Assemble (4) end covers and (4) hinges into the formation shown in the illustration below, leaving two end covers directly across from each other, 1/2” higher than the other two.
- 2 Assemble panels “B” and “D” according to straight panel assembly.
- 3 Move panel “A” in direction of arrow until the slots and inner upright tabs intersect. Make sure slot cover is free of top tabs, then tighten socket head screw until top of end cover is level with top of upright.
- 4 Move panel “C” in direction of arrow, then repeat step 3.

Note: If hinges are too stiff and the high end cover does not easily slide down to engage with the inner upright tabs, alternate turning the socket head screw down and lightly tapping the top of the end cover using a rubber mallet and screwdriver.

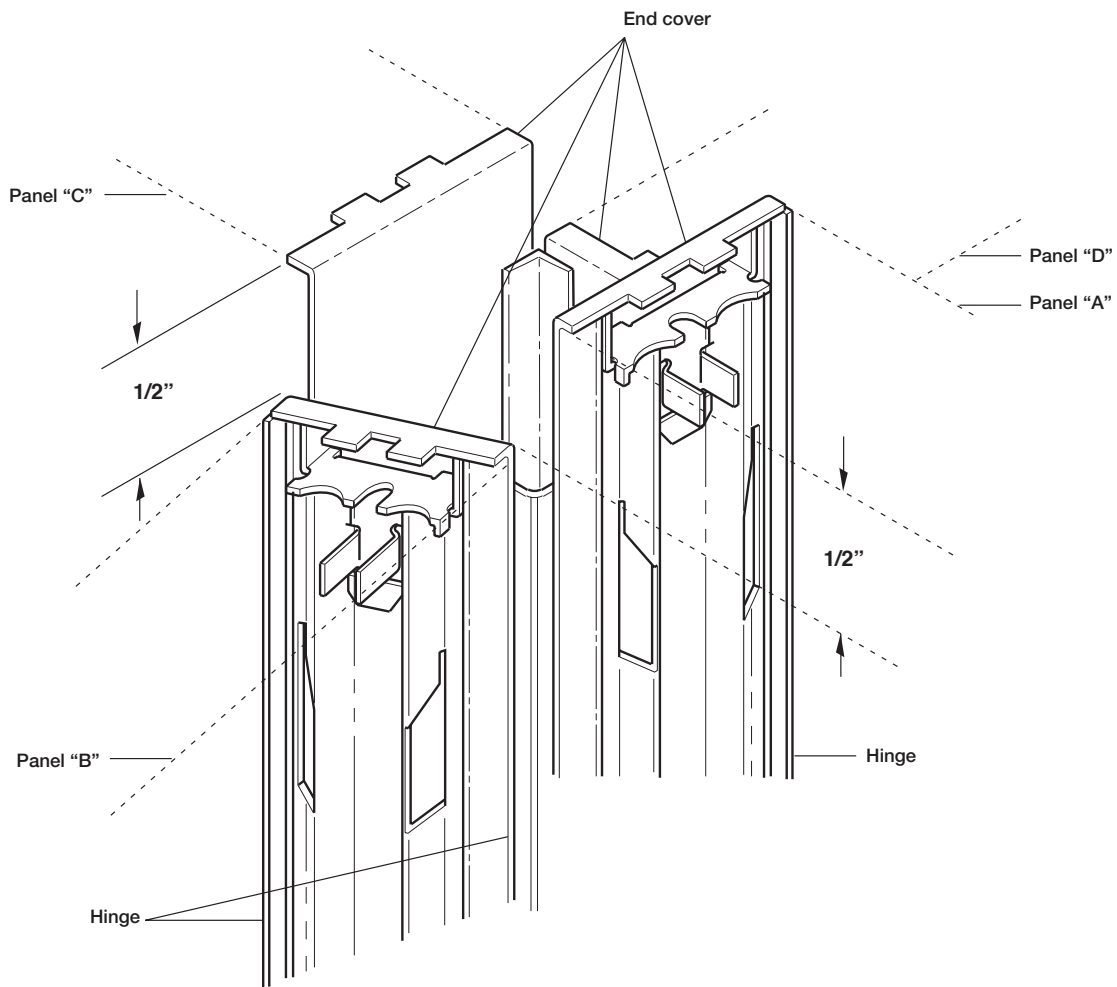

Replacement of a Panel in a “Y”, “T”, or “X” Arrangement

- 1 Remove original panel by backing off socket head screw and detaching panel from end cover and hinge assembly.
- 2 Pre-set end cover 1/2" higher than adjacent end cover.
- 3 Position new panel to match with end cover and tighten socket head screw until top of end cover is level with top of upright.

Note: If hinges are too stiff and the high end cover does not easily slide up, use a long shank screwdriver tapping up under retainer on end cover until 1/2" is attained.

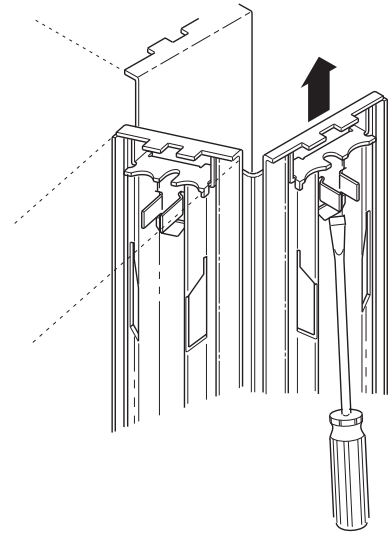

Panel Interchangeability

Note: Use end covers only with revised inner uprights and original end covers only with original inner uprights.

The original panel system manufactured before August 1979 and the revised panel system manufactured after August 1979 can be connected to each other by using the revised hinge. The revised hinge must be shortened 5/16" on top to fit the original end cover.

Note: Does not include #9000 34-1/2", C9000 34-1/2", and C9000 energy management panels.

Note: For C9000 panels manufactured after August 1979 only.

- 1 Remove 1-3/8" from top of hinges.

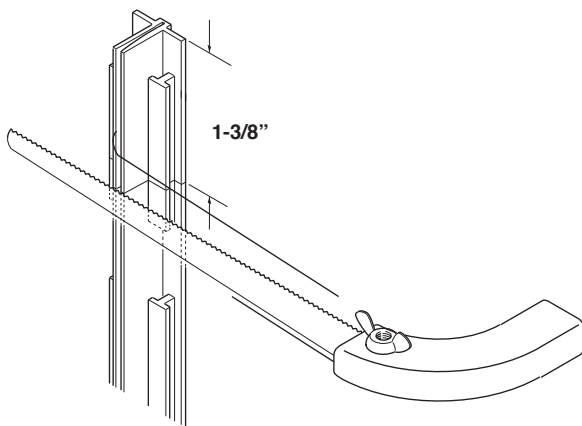

- 2 Attach hinges to conventional and enhanced end covers.

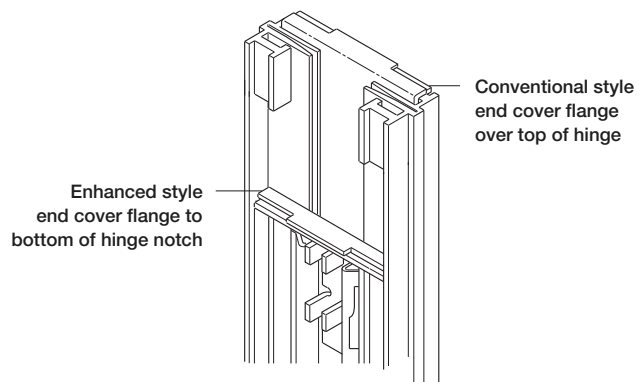

Knock-Out Removal

Lay base trim flat on surface with knock-out extended out over edge, hold base plate down against surface with one hand. Using a small hammer and your other hand provide a sharp blow to the center of the knock-out.

Note: Strike as close to the center as possible, avoid striking along the outline of the knock-outs.

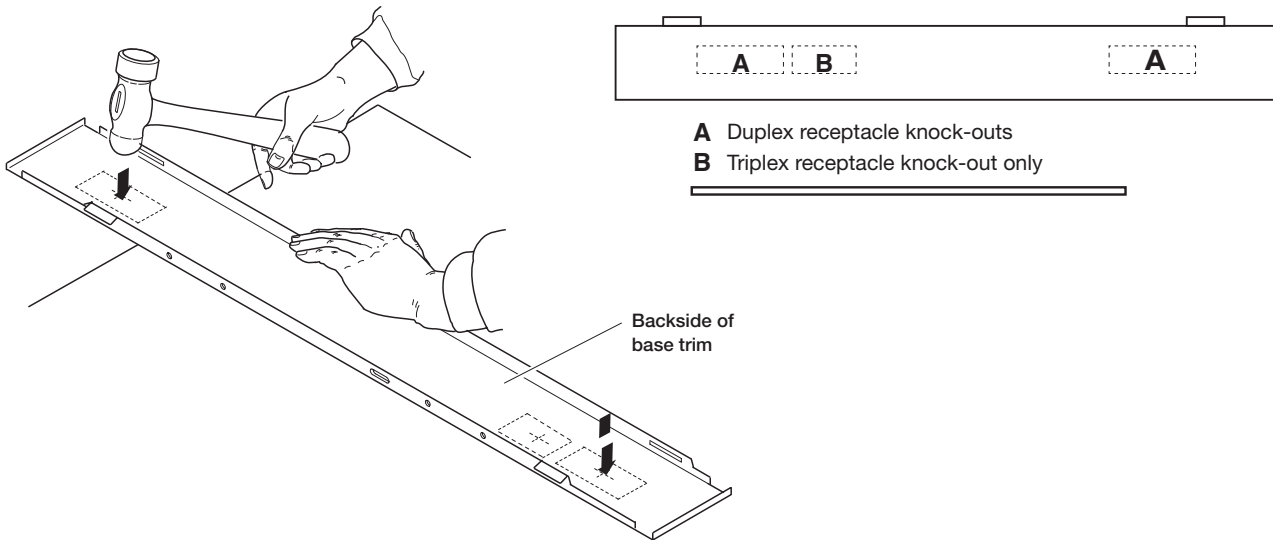

- 1 For duplex receptacle installation: Remove the larger single knock-out as shown. A duplex receptacle may also be installed in the larger of the opening on triplex side of base trim. Do not remove smaller knock-out. Assemble panels "B" and "D" according to straight panel assembly.
- 2 For triplex receptacle installation: First remove both knock-outs located next to one another as shown. Then, with a pair of tin snips cut the center web in half. Using a pair of pliers break the two halves away from the base trim.

