

OLIVER

Technologies, Inc.



467 Swan Ave • Hohenwald, TN 38462 • (800) 284-7437 • www.olivertechnologies.com • Fax (931) 796-8811

Installation Instructions for 1100 "V" Series All Steel Foundation System



Installation Instructions for 1100 "V" Series All Steel Foundation System

SPECIAL CIRCUMSTANCES: If following conditions occur - STOP! Contact Oliver Technologies at 1-800-284-7437 for further instructions:

- a) Pier (system) height exceeds 48"
- b) Roof eaves exceed 16"
- c) Roof pitch greater than 7/12
- d) Location is within 1500 feet of coastline
- e) Soil conditions less than 4B
- f) Thick and wide I Beam attachments are available.

INSTALLATION OF GROUND PAN FOR DIRT SET (IV)

- 1) Remove weeds and debris in an approximate three foot square to expose firm, level undisturbed soil or controlled fill for each ground pan. The 1100 V Pan is equivalent to a 21 x 21 footing. Top of ground pan (C) must be installed at ground level or per local jurisdiction.
- 2) Place center ground pan (C) directly below chassis I-beam. Press or drive pan completely into soil until flush with or below soil.

SPECIAL NOTE: The longitudinal "V" brace system serves as a pier under the home and should be loaded as any other pier. It is recommended that after leveling piers, and one-half inch (1/2") before home is lowered completely onto piers, complete items 3 through 7 below.

INSTALLATION OF LONGITUDINAL "V" BRACE SYSTEM

- 3) Select the correct square tube brace (E) length for set-up (pier) height at support location.

PIER HEIGHT (Approx. 40-60 degrees Max.)	1.5" Tube Length
---	---------------------

14" to 18"	20"
18" to 25"	28"
24" to 35"	39"
30" to 40"	44"
36" to 48"	54"

PIER HEIGHT = the dimension from the top of the pan to the bottom of the I-Beam

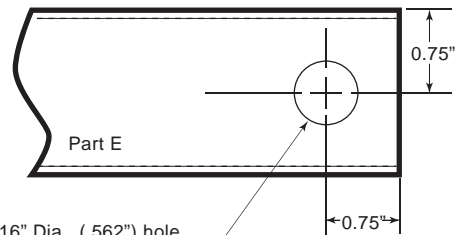

- 4) Install both of the 1.5" square tubes (E) into the "V" bracket (J), insert carriage bolt and leave nut loose for final adjustment.
- 5) Place I-beam connector (F) loosely on the bottom flange of the I-beam.
- 6) Attach the selected 1.5" tubes (E) to the I-beam connectors (F) and fasten loosely with bolts and nuts. NOTE: The ground pan must be level in both directions to ensure the angle markings on the center point connector are correct from the horizontal plane of the pan. The angle is not to exceed 60 degrees and not less than 40 degrees. The "V" bracket (J) is stamped with the angles to verify correct degree. Use proper length tube or cut and drill tube to achieve proper length. (The tube may be cut using any appropriate steel cutting method such as steel saw, cutting torch, etc. New holes must be drilled to the dimension and at the location as shown for part (E).
- 7) Using standard hand tools, tighten all nuts and bolts. When connecting the brace tube to the model 1100-10-P I-beam connector bracket, tighten at least one and a half to two full turns past hand tight.

INSTALLATION OF (LATERAL) TELESCOPING TRANSVERSE ARM SYSTEM (1100 ITV)

- 8) Select the correct transverse arm (H). The 60" sections are standard. The 72" sections are used on frame widths greater than 99.5".
- 9) Install the 1.5" transverse brace (H) to the ground pan connector (D) with the bolt and nut.
- 10) Slide 1.25" transverse brace into the 1.5" brace and attach to adjacent I-beam connector (I) with bolt and nut.
- 11) Secure 1.5" transverse arm to 1.25" transverse arm using four (4) 1/4" - 14 x 3/4" self-tapping screws in pre-drilled pilot holes.

INSTALLATION USING CONCRETE (ICV)

The concrete footer, runner or slab may be of any shape, that has a minimum of 2900 cu. in., with a minimum depth of 3.5" (dry set) or 6" (wet set), at each system location. The surface of the footing shall be large enough to support the pier load and allow at least 4" from the concrete bolt to the edge of the concrete (ie. 22"x22"x6" footer). The concrete shall be a minimum of 2500 psi mix (pre-blended sacked concrete mix is acceptable). Special inspection of footing is not required. If the 1100 ITC transverse system, (D (W or D) bracket only) is to be installed without the use of the 1100 ILC (V) longitudinal system (J (W or D) bracket), it MUST be installed within 18" of pier.

NOTE: The bottom of all footings, pads, slabs and runners must be per local jurisdiction.

LONGITUDINAL (V)

When using the 1100 wet set J(W) bracket, simply install the bracket in runner/footer OR when installing in cured concrete, use the 1100 dry set J(D) bracket. The 1100 dry set J(D) bracket is attached to the concrete using (2) 1/2" X 3" concrete wedge bolts. Place the bracket in desired location. Mark bolt hole locations, then using a 1/2" masonry bit, drill a hole to a minimum depth of 3". Be sure all dust is blown out of the holes. Place wedge bolts into drilled holes, then place 1100 J(D) bracket onto wedge bolts and start wedge bolt nuts. Take a hammer and lightly drive the wedge bolts down by hitting the nut (Do not hit the top of threads on bolt). Complete by tightening the nuts.

LATERAL (Transverse Arm)

For wet set installation set the transverse connector bracket D(W) into runner/footer at desired location. For dry set installations, the transverse connector bracket D(D) is attached to the concrete using (2) 1/2" X 3" concrete wedge bolts. Mark bolt hole locations, then using a 1/2" masonry bit, drill a hole to a minimum depth of 3". Be sure all dust is blown out of the holes. Place wedge bolts into drilled holes, then place transverse connector bracket J(D) bracket onto wedge bolts and start wedge bolt nuts. Take a hammer and lightly drive the wedge bolts down by hitting the nut (Do not hit the top of threads on bolt.) Complete by tightening the nuts.

**REQUIRED NUMBER AND LOCATION OF MODEL
1100 "V" SERIES BRACES FOR 4/12 & 5/12**

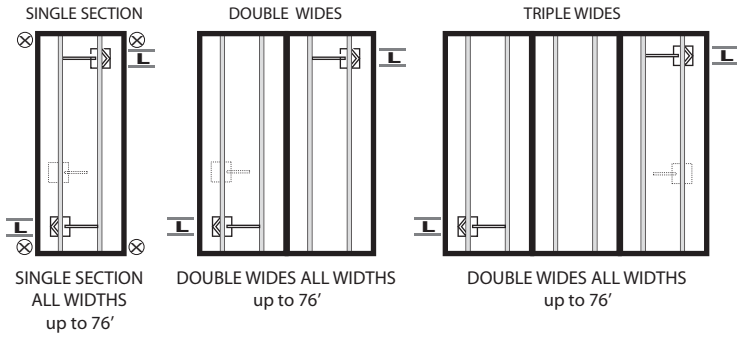

**REQUIRED NUMBER AND LOCATION OF MODEL
1100 "V" SERIES BRACES FOR 6/12 & 7/12**

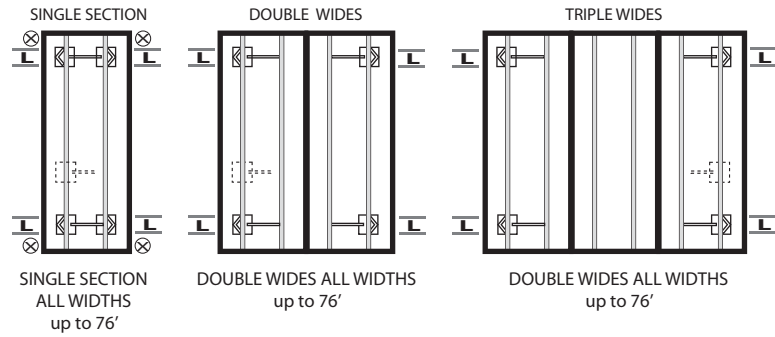

LEGEND:

1. - - Approximate location of the system (See note H)
2. - - Location of ASF Model 1100 "V" (Lateral and Longitudinal Bracing) or 1100 T (Lateral only)
3. - - Location of additional ASF Model 1100 T "V" System (Lateral only) for homes exceeding 76' in length or with roof pitch between 4.37/12 (20 degrees) and 5/12, the additional system is to be installed at approximately the midpoint of the house and may be installed at either exterior beam.
4. - - Installation of single wide homes require two (2) anchors per side located not more than ten (10) feet from each end (with a minimum of 3150 load rating)
5. - - Location of additional ASF Model 1100 T "V" System (Lateral only) for homes exceeding 76' in length, sidewall height exceeding 96" or with roof pitch between 6/12 & 7/12 the additional system is to be installed at approximately the midpoint of the house and may be installed at either exterior beam.

(Length of house is actual box size)

NOTE:

- a) Installation of the longitudinal system eliminates the need for the longitudinal anchors.
- b) Installation of the transverse system eliminates the need for all anchors, diagonal frame ties and stabilization plates except when noted. (Legend #5 & note C)
- c) All other home manufacturer's instructions for installation of stabilizing devices must be followed, including installation of vertical tie-down anchors, and mating line column, shear wall or center-line tie-down anchors. NOTE WIND ZONE II: ALL VERTICAL ANCHORS (NOT TO EXCEED 8' SPACING) MUST BE INSTALLED PER MANUFACTURER'S INSTALLATION INSTRUCTIONS!
- d) If the home manufacturer's installation instructions are not available, the home must be installed in accordance with any state promulgated rules or as required by the authority having jurisdiction.
- e) If bolts, nuts and tech screws are lost, they may be replaced as long as they meet or exceed the specs for OTI ASFS hardware.
- f) When the length of home exceeds 76', sidewall height exceeds 96" or the roof pitch is between 4.37/12 (20 degrees) and 5/12, add 1 transverse system (see location diagrams above) 6/12: a total of 4 Transverse & 3 Longitudinal systems are needed & 7/12: a total of 5 Transverse & 3 Longitudinal systems are needed. (Longitudinal portion only required when longitudinal bracing is required by home manufacturer).
- g) An alternative method using the 1100 CVD anchors (dry set) or 1100 CVW (wet set) may be used on a footing size of 16" diameter X 24" depth. These brackets are designed for lateral and longitudinal protection.
- h) It is recommended that the systems be installed at the 2nd pier in from each end of the house. However, they may be installed at any location at least 2 feet, but not more than 1/4 the house length, in from the ends of the home.

STATE OF MICHIGAN ONLY: As required by Section 1805.2 of the 200 Michigan Building Code, the depth of the footer shall be a minimum depth of 42 inches below grade, except that the authority having jurisdiction may approve a lesser depth based on known prevailing soil and weather conditions, or as provided by the exception under Section 1805.2.1 of the Code.

STATE OF ALABAMA ONLY: Maximum pier height is limited to 32" with pier defined in the Alabama Regulation as "that portion of the support system between the top of the footing and the bottom of the pier cap."

The State of Alabama limits the use of this system to H.U.D labeled homes.

STATE OF NORTH CAROLINA ONLY:

Tubing must be galvanized and, when the manufacturer's installation instructions are not available, vertical wall tie-downs must be installed not to exceed 8-feet on center. (Wind Zone II)

STATE OF IDAHO ONLY:

Concrete must be a minimum of 8" in depth.

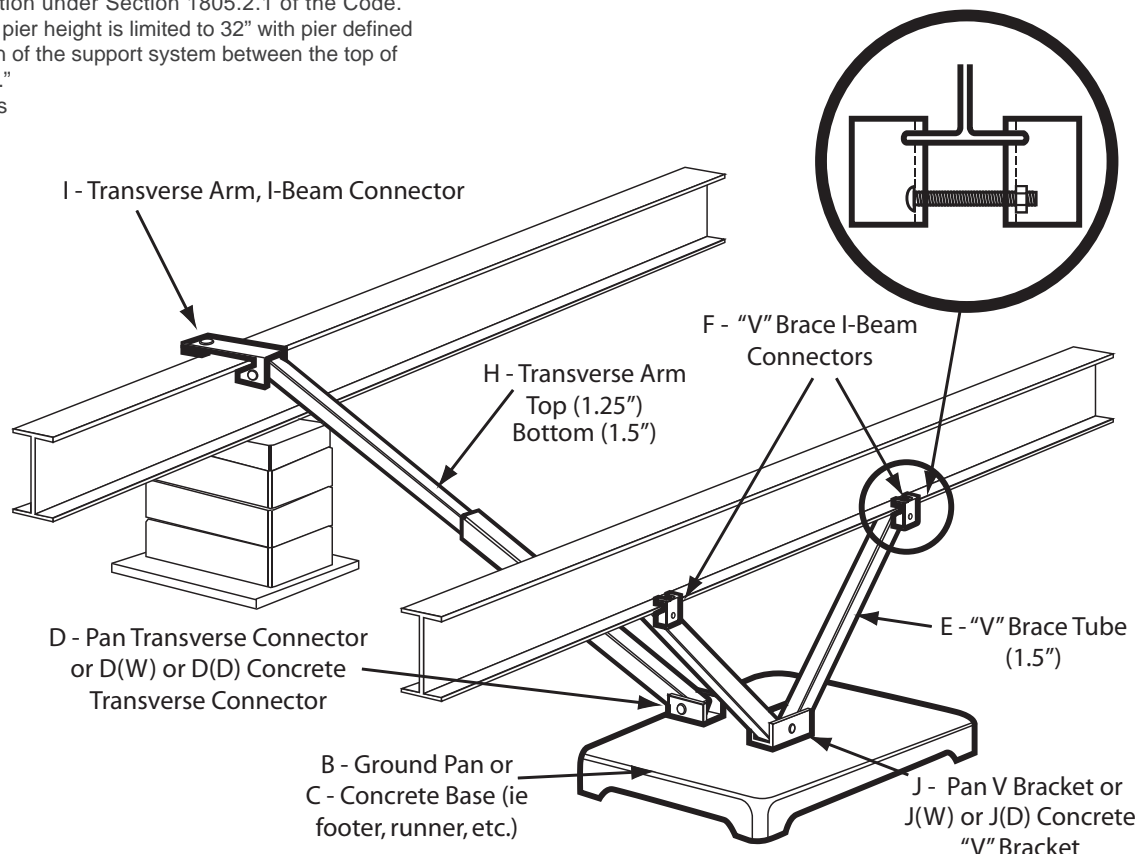

OLIVER

467 Swan Ave
Hohenwald, TN 38462
(800) 284-7437
www.olivertechnologies.com