

Paper-band coolant Filtration Systems with or without magnetic separator

Our standard paper filter tanks are suited
For all types of grinding and cutting oil applications.

Filtration effect is subject to paper density.
For rough filtering we recommend our
magnetic separator.

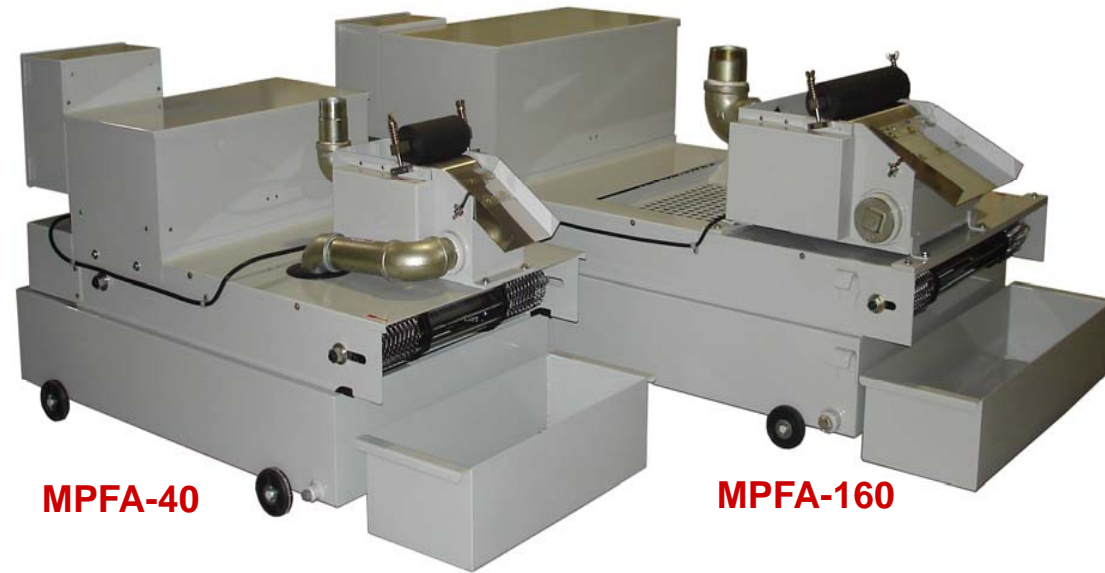

Replacement Paper Rolls

Each machine comes equipped with one roll of filter paper
replacement rolls are readily available from our inventory

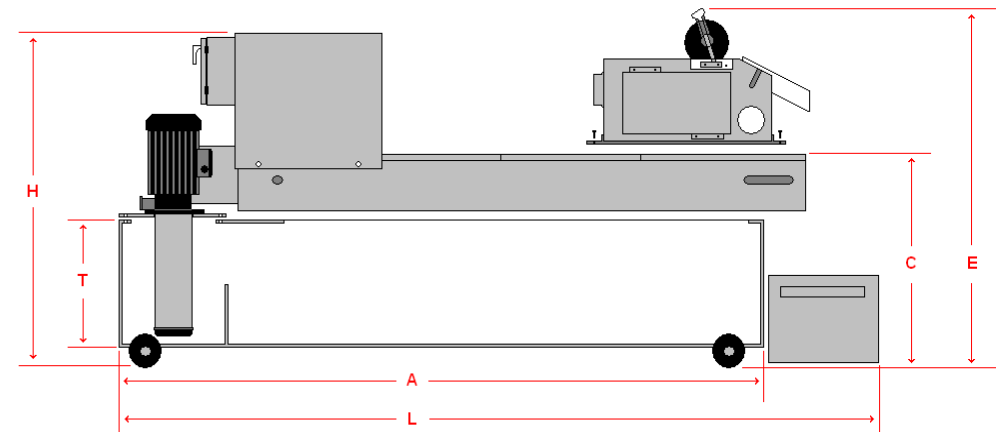
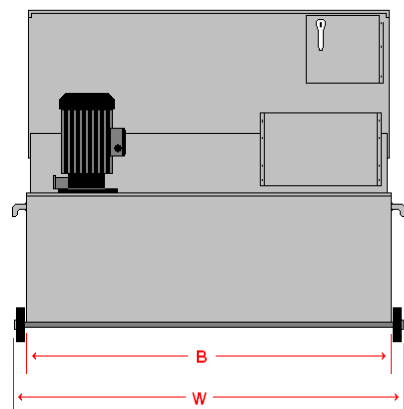

Unit / mm

Model	Disposal Capacity	Water Tank Capacity	L	A	B	C	D	E	W	H	PUMP	Paper Motor	PAPER	Remarks
MPFA-20	20	80	1050	850	600	350	500	655	720	610	1/8-hp PF-1/2"	25W		
MPFA-40	40	120	1200	1000	600	400	550	705	720	660	1/8-hp PF-1/2"	25W	500mm x 200yds	
MPFA-60	60	140	1350	1150	600	400	555	705	720	660	1/8-hp PF-1/2"	25W		Wheels
MPFA-80	80	160	1500	1300	600	400	555	705	720	660	1/4-hp PF-3/4"	25W		
MPFA-120	120	210	1500	1300	800	400	590	750	920	740	1/2-hp PF-3/4"	40W	700mm x 200yds	
MPFA-160	160	260	1800	1600	800	400	605	750	920	740	1/2-hp PF-3/4"	40W		
MPFA-240	240	440	1550	1350	1060	430	640	915	1330	740	1-hp PF-1"	40W	1000mm x 200yds	No Wheels
MPFA-360	360	640	2150	1950	1060	430	640	915	1330	740	1-hp PF-1"	40W		

Standard tank height "T" is 200mm (8").
Custom tank dimension for increased capacity can be
manufactured to your requirements.

Multiple coolant pumps can be installed to service more
than one machine or application.



Paper band filters can be equipped with or without
magnetic separator. For rough filtering of aggressive
machining applications a magnetic separator
is recommended.



Other features can be added as per your application

cooling system to manage coolant temperature
oil skimmers to eliminate tramp oils
Specialty high pressure supply pumps



Pumps are equipped with a pre-filter
adding one more layer of filterability.

