



目录	页面	Contents	Page
<b>XB系列摆线针轮减速机</b>		<b>XB Series Cycloidal Pin Wheel Gear Unit</b>	
产品外形	101-101	Products Figure	101-101
型号标记	102-102	Designation	102-102
电机配置说明	103-104	Configuration	103-104
安装位置	105-106	Mounting Position	105-106
技术参数	106-131	Technical Data	106-131
安装尺寸	132-173	Mounting Dimensions	132-173



产品外形

Products Figure

**XWD..**  
**BWD..**

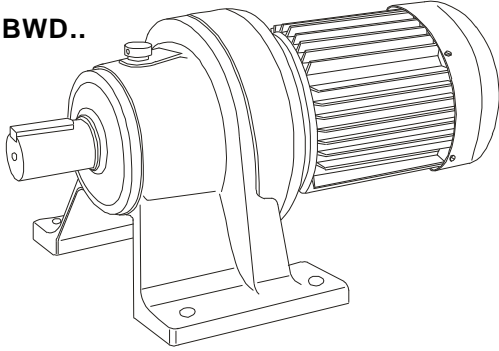

**XLD..**  
**BLD..**

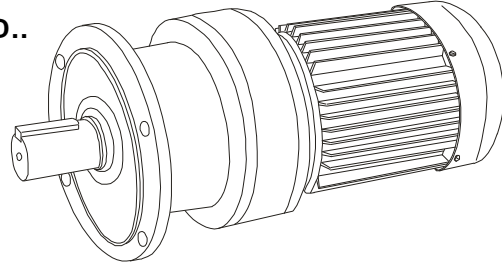

**XW..**  
**BW..**

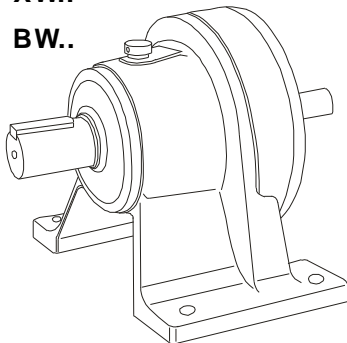

**XL..**  
**BL..**

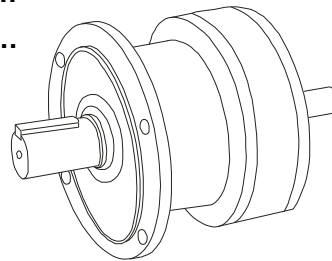

**XW..B5**  
**BW..B5**

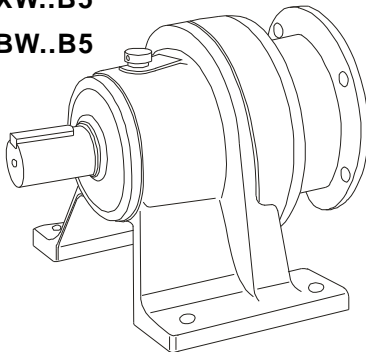

**XL..B5**  
**BL..B5**

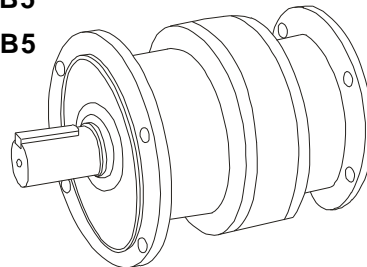



## 型号标记

## Designation

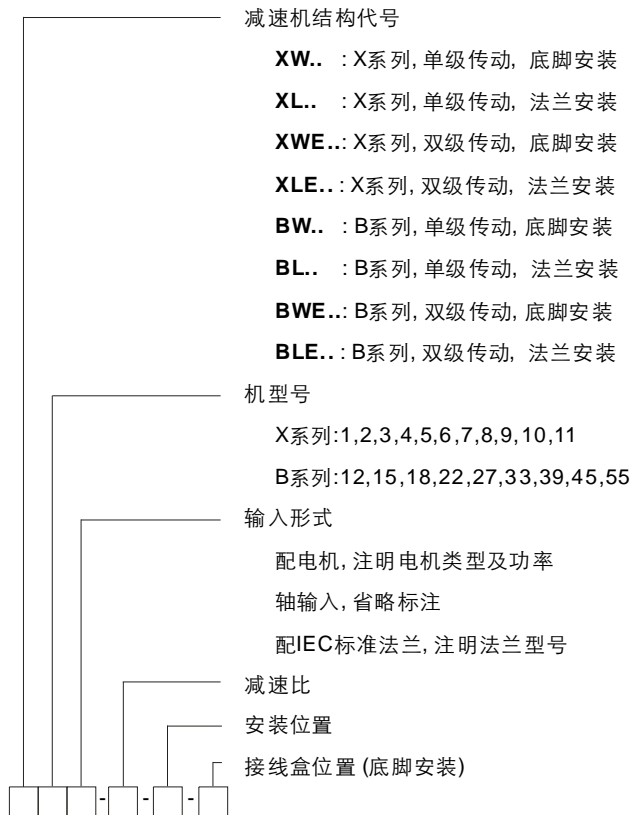

gear unit type

- XW..** : X series, single stage, foot-mounted
- XL..** : X series, single stage, flange-mounted
- XWE..** : X series, double stage, foot-mounted
- XLE..** : X series, double stage, flange-mounted
- BW..** : B series, single stage, foot-mounted
- BL..** : B series, single stage, flange-mounted
- BWE..** : B series, double stage, foot-mounted
- BLE..** : B series, double stage, flange-mounted

gear unit size

- X series: 1,2,3,4,5,6,7,8,9,10,11
- B series: 12,15,18,22,27,33,39,45,55

input structure:

- connect with motor, indicate motor type and power
- with input shaft, omit sign
- connect with IEC flange, indicate flange frame

transmission ratio

mounting position

terminal box position for foot-mounted

### 标记示例

- A XW490L-4-43-M1-0**  
X系列, 单级传动, 卧式底脚安装, 电机90L-4(1.5KW), 机型号4, 减速比43, 安装位置M1, 接线盒位置0
- B BWD22132S-4-17-M1-270**  
B系列, 单级传动, 卧式底脚安装, 电机132S-4(5.5KW), 机型号22, 减速比17, 安装位置M1, 接线盒位置270
- C XLE53YB90L-4-121-M4-270 (dII BT4, IP54/F)**  
X系列, 双级传动, 立式法兰安装, 防爆电机YB90L-4(1.5KW, dII BT4 IP54/F), 机型号53, 减速比121, 安装位置M4, 接线盒位置270
- D XLE53-90B5-121-M4**  
X系列, 双级传动, 立式法兰安装, 带IEC90B5输入法兰, , 机型号53, 减速比121, 安装位置M4
- E XW4-43-M1**  
X系列, 单级传动, 卧式底脚安装, 带输入轴, 机型号4, 减速比43, 安装位置M1

### Sign Example

- A XW490L-4-43-M1-0**  
X series, single stage, foot-mounted, with motor 90L-4 (1.5KW), gear unit size 4, transmission ratio 43, mounting position M1, terminal box position 0
- B BW22132S-4-17-M1-270**  
B series, single stage, foot-mounted, with motor 132S-4 (5.5KW), gear unit size 22, transmission ratio 17, mounting position M1, terminal box position 270
- C XLE53YB90L-4-121-M4-270 (dII BT4, IP54/F)**  
X series, double stage, flange-mounted, with explosion proof motor YB90L-4(1.5KW), protection IP54/F, gear unit size 53, transmission ratio 121, mounting position M4, terminal box position 270.
- D XLE53-90B5-121-M4**  
X series, double stage, flange-mounted, with input flange 90B5, gear unit size 53, transmission ratio 121, mounting position M4
- E XW4-43-M1**  
X series, single stage, foot-mounted, input shaft, gear unit size 4, transmission ratio 43, mounting position M1



## 电机配置说明

## Configuration of Electric Motor

### Y系列普通三相异步电机

- 1 本系列减速机标准配置Y系列普通三相异步感应电机;
- 2 电机电压: 380V/50Hz;
- 3 电机防护等级IP54, 绝缘等级F, B级温升;
- 4 环境温度不超过40℃, 不低于-15℃;
- 5 连续工作制S1;
- 6 海拔高度不超过1000m;
- 7 冷却方式为C0141 (风扇自冷);
- 8 100L2及以下规格为"Y"接法, 112M及以上规格为"Δ"接法;
- 9 优先选用 4, 6, 8极电机
- 10 电机技术参数见第189-194页

### YEJ系列三相异步制动电机

- 1 三相异步制动电机为普通电机的基础上附加制动器;
- 2 电机电压: 380V/50Hz;
- 3 制动器电压: 规格71~100: DC99V  
规格112~200: DC170V
- 4 配置单相AC220/50Hz整流器;
- 5 电机防护等级IP44, 绝缘等级F, B级温升;
- 6 环境温度不超过40℃, 不低于-15℃;
- 7 连续工作制S1;
- 8 海拔高度不超过1000m;
- 9 冷却方式为C0141 (风扇自冷);
- 10 100及以下规格为"Y"接法, 112M及以上规格为"Δ"接法;
- 11 优先选用 4, 6, 8极电机, 2极电机不推荐使用。
- 12 电机技术参数见第189-194页

### YVF系列三相异步变频电机

- 1 电机电压: 380V;
- 2 基准频率: 50Hz;
- 3 允许调频5~50Hz, 恒转矩调速;
- 4 电机防护等级IP54, 绝缘等级F, B级温升;
- 5 环境温度不超过40℃, 不低于-15℃;
- 6 连续工作制S1;
- 7 海拔高度不超过1000m;
- 8 冷却方式为C416 (独立风扇);
- 9 接线方式按适配变频器要求;
- 10 优先选用 4极电机。

### Y series Three-phase Asynchronous Electric Motor

- 1 this series gear unit configure three-phase asynchronous electric motor;
- 2 voltage:380V/50Hz;
- 3 protection class:IP54,insulation class: F; temperature rising class: B;
- 4 ambient temperature:-15~40℃;
- 5 continue working duty:S1;
- 6 altitude less than 1000m;
- 7 self-cooling with fan:C0141;
- 8 within frame 100, follow connection Y, from frame 112, follow connection Δ;
- 9 first select 4,6,8 poles motor;
- 10 technical data on page 189-194.

### YEJ series Three-phase Asynchronous Brake Motor

- 1 base on Y series motor, add a brake.
- 2 voltage:380V/50Hz;
- 3 brake voltage: frame:71~100 DC99V  
frame:112~200 DC170V;
- 4 with single phase AC220V/50Hz rectifier;
- 5 protection class:IP54,insulation class: F, temperature rising class: B;
- 6 ambient temperature:-15~40℃;
- 7 continue working duty:S1;
- 8 altitude less than 1000m;
- 9 self-cooling with fan:C0141;
- 10 within frame 100, follow connection Y, from frame 112, follow connection Δ;
- 11 first select 4,6,8 poles motor;
- 12 technical data on page 189-194.

### YVF series Three-phase Variable-frequency Motor

- 1 voltage:380V;
- 2 rated frequency 50Hz;
- 3 available frequency:5~50Hz;
- 4 protection class:IP54,insulation class: F, temperature rising class:B;
- 5 ambient temperature:-15~40℃;
- 6 continue working duty:S1;
- 7 altitude less than 1000m;
- 8 cooling with independence fan:C416;
- 9 connection perform the requirement of inverter;
- 10 first select 4 poles motor;



## 电机配置说明

### 特殊电机

- 1 选用包括防爆电机, 辊道电机, 船用电机, 多速电机等特殊电机, 本公司提供IEC标准电机法兰接口, 接口尺寸见171,172页;
- 2 异频率, 异电压电机, 请联系本公司技术部;
- 3 使用环境温度不在-15~40℃范围内, 请联系本公司技术部;
- 4 更高的绝缘等级及防护等级, 请联系本公司技术部。

## 电机与减速机配置说明

### 电机与减速机直联配置

适用机型:X系列1, 2, 3, 4

适用机型:B系列12, 15, 22

订货须知:

无注明时, 工厂按直联配置供货

## Configuration of Electric Motor

### Customized Motor

- 1 others like explosion proof, roller motor, marine motor or multi-speed motor coupled by adaptor, the dimensions on page 431.
- 2 need different frequency and voltage, please contact us.
- 3 ambient temperature is not in -15~40℃, please contact us.
- 4 for higher insulation and protection class, please contact us.

## Configuration of Electric Motor & Gear Unit

### Direct connection between gear unit and motor

Applied following size

X series gear unit size:1,2,3,4

B series gear unit size:12,15,22

default supply:

SGR company supply direct connection in these size

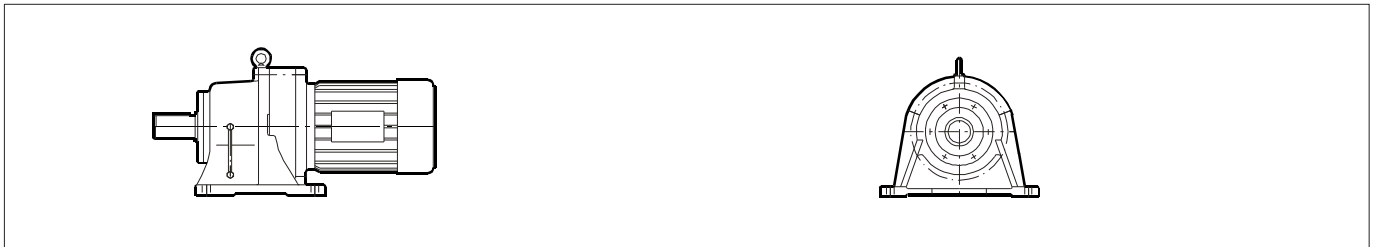

### 电机与减速机带过渡法兰配置

适用机型:X系列1, 2, 3, 4, 5, 6, 7, 8, 9, 10, 11

适用机型:B系列12, 15, 22, 27, 33, 39, 45, 55

订货须知:

X系列1, 2, 3, 4,

B系列12, 15, 22

加过渡法兰配置, 订货需附加说明:

X系列5, 6, 7, 8, 9, 10, 11

B系列 27, 33, 39, 45, 55

一律按加过渡法兰配置供货

### Gear unit couple IEC motor by IEC adapter

Applied following size

X series gear unit size:1, 2, 3, 4, 5, 6, 7, 8, 9, 10, 11

B series gear unit size:12, 15, 22, 27, 33, 39, 45, 55

matters should know when order:

X series 1, 2, 3, 4,

B series 12, 15, 22

if need IEC adapter, should indicate when order

X series 5, 6, 7, 8, 9, 10, 11

B series 27, 33, 39, 45, 55

SGR supply gear unit with IEC adapter in these size





安装位置

Mounting Position

XW.., BW..型减速机安装位置

XW.., BW.. type Gear Unit Mounting Position

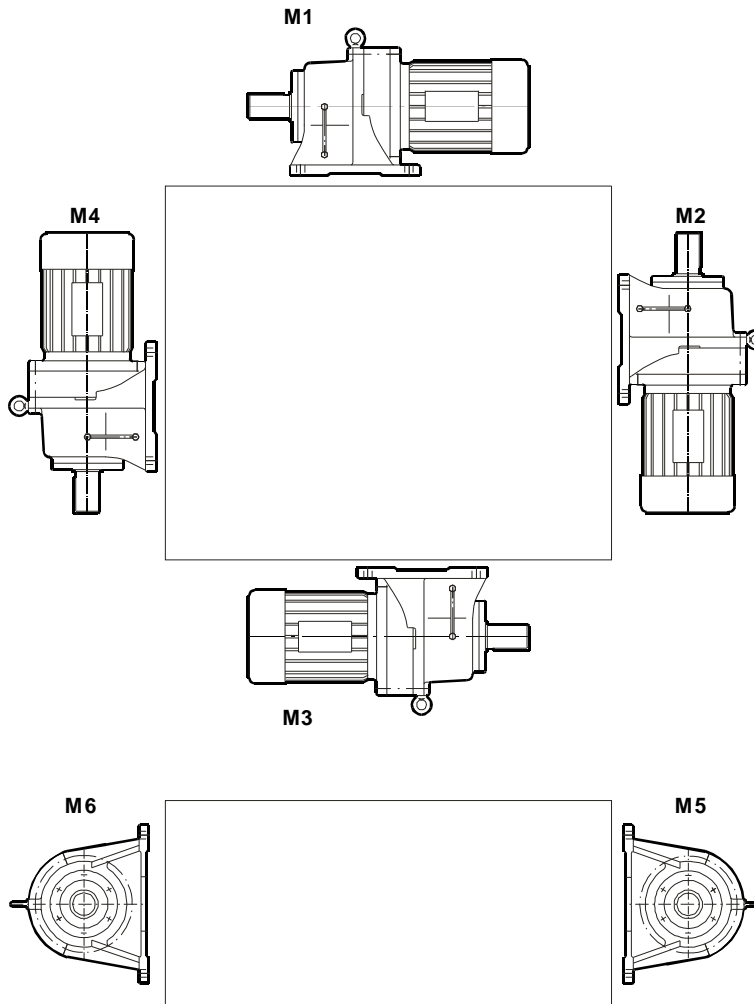

接线盒位置

Terminal Box Position

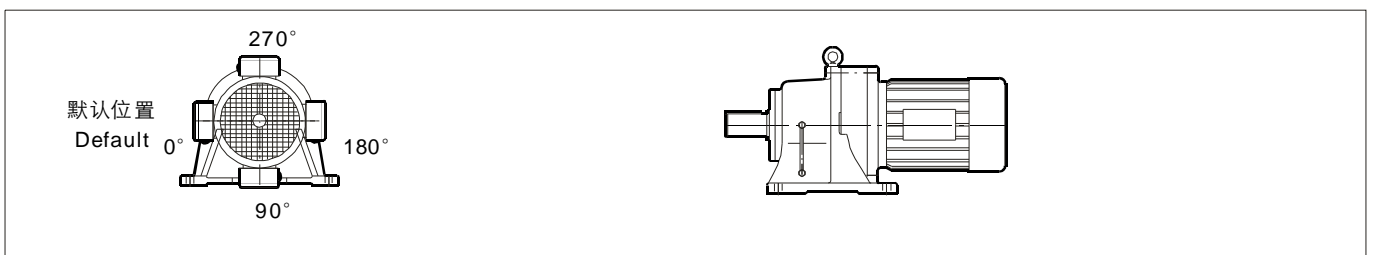



安装位置

Mounting Position

XL..., BL... 减速机安装位置

XL..., BL... type Gear Unit Mounting Position

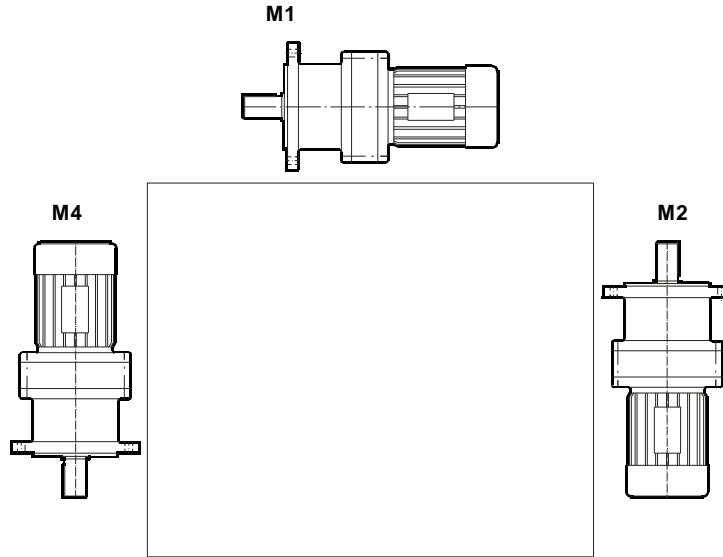

技术参数

Technical Data

符号意义

Key to Symbols



**$P_1 = 0.12 \text{ kW}$**

<b>N<sub>A</sub></b> rpm	<b>M<sub>2</sub></b> Nm	<b>i</b>	<b>Fr<sub>2MAX</sub></b> [N]	<b>f<sub>s</sub></b>	<b>Type</b>	<b>Gear unit</b>	<b>Motor size</b>	 Kg
4.4	237	319	2550	1.05	XWE	31	63M1-4	42
4.8	215	289	2550	1.16	XLE	31	63M1-4	42
7.4	139	187	2550	1.80				



- 1 电机功率
- 2 输出转速
- 3 输出转矩
- 4 减速比
- 5 输出轴中最大点载荷
- 6 使用系数
- 7 减速机类型
- 8 减速机规格
- 9 电机型号
- 10 大概重量

- 1 motor power
- 2 output speed
- 3 output torque
- 4 transmission ratio
- 5 maximum load on middle output shaft
- 6 service factor
- 7 gear unit type
- 8 gear unit size
- 9 motor frame
- 10 approximate weight



技术参数

Technical Data

<b>P<sub>1</sub> = 0.12 kW</b>								
--------------------------------	--	--	--	--	--	--	--	--

N <sub>A</sub> rpm	M <sub>2</sub> Nm	i	Fr <sub>2MAX</sub> [N]	f <sub>s</sub>	Type	Gear unit	Motor size	Kg
4.4	237	319	2550	1.05	XWE	31	63M1-4	42
4.8	215	289	2550	1.16	XLE	31	63M1-4	42
7.4	139	187	2550	1.80				

<b>P<sub>1</sub> = 0.18 kW</b>								
--------------------------------	--	--	--	--	--	--	--	--

7.4	209	187	2550	1.20	XWE	31	63M2-4	43
11.5	135	121	2550	1.85	XLE	31	63M2-4	43
10	167	87	1900	0.90				
12	136	71	1900	1.10	XW	2	71M1-6	21
14	113	59	1900	1.32	XL	2	71M1-6	21
20	80	43	1900	1.87	BW	12	71M1-6	21
24	67	35	1900	2.23	BL	12	71M1-6	21
29	56	29	1900	2.69				
15	105	43	1900	1.42	XW	2	80M1-8	31
18	89	35	1900	1.69	XL	2	80M1-8	31
22	73	29	1900	2.04	BW	12	80M1-8	31
28	58	23	1900	2.58	BL	12	80M1-8	31
20	80	43	420	0.87				
24	67	35	420	1.04	XW	1	71M1-6	15
29	56	29	420	1.26	XL	1	71M1-6	15
37	44	23	420	1.58				
50	33	17	420	2.14				
28	58	23	420	1.20				
38	43	17	420	1.63	XW	1	80M1-8	25
59	28	11	420	2.51	XL	1	80M1-8	25
72	23	9	420	3.07				

<b>P<sub>1</sub> = 0.25 kW</b>								
--------------------------------	--	--	--	--	--	--	--	--

0.9	2210	1505	7650	0.90				
1.1	1799	1225	7650	1.11				
1.4	1473	1003	7650	1.36	XWE	63	71M1-4	155
1.7	1235	841	7650	1.62	XLE	63	71M1-4	155
1.9	1073	731	7650	1.86	BWE	2715	71M1-4	155
2.3	922	595	7650	2.17	BLE	2715	71M1-4	155
2.9	733	473	7650	2.73				
1.7	1235	841	5660	0.81				
1.9	1073	731	5660	0.93	XWE	53	71M1-4	101
2.3	922	595	5660	1.08	XLE	53	71M1-4	101
2.9	733	473	5660	1.36	BWE	53	71M1-4	101
4.4	494	319	5660	2.02	BLE	53	71M1-4	101
4.8	448	289	5660	2.23				



技术参数

Technical Data

<b>P<sub>1</sub> = 0.25 kW</b>								
--------------------------------	--	--	--	--	--	--	--	--

N <sub>A</sub> rpm	M <sub>2</sub> Nm	i	Fr <sub>2MAX</sub> [N]	f <sub>s</sub>	Type	Gear unit	Motor size	Kg
4.4	494	319	3960	1.01	XWE	42	71M1-4	82
4.8	448	289	3960	1.12	XLE	42	71M1-4	82
7.4	290	187	3960	1.73	BWE	1812	71M1-4	82
11.5	188	121	3960	2.67	BLE	1812	71M1-4	82
<hr/>								
16	137	87	1900	1.09	XW	2	71M1-4	21
20	112	71	1900	1.34	XL	2	71M1-4	21
24	93	59	1900	1.61	BW	12	71M1-4	21
32	68	43	1900	2.21	BL	12	71M1-4	21
40	57	35	1900	2.63				
<hr/>								
14	152	59	1900	0.98	XW	2	71M2-6	21
20	111	43	1900	1.35	XL	2	71M2-6	21
24	93	35	1900	1.61	BW	12	71M2-6	21
29	77	29	1900	1.94	BL	12	71M2-6	21
37	61	23	1900	2.44				
<hr/>								
15	146	43	1900	1.02	XW	2	80M2-8	32
18	119	35	1900	1.26	XL	2	80M2-8	32
22	99	29	1900	1.52	BW	12	80M2-8	32
28	81	23	1900	1.85	BL	12	80M2-8	32
38	60	17	1900	2.51				
<hr/>								
32	68	43	420	1.03	XW	1	71M1-4	15
40	57	35	420	1.23	XL	1	71M1-4	15
48	47	29	420	1.48				
60	38	23	420	1.87				
82	28	17	420	2.52				
<hr/>								
29	77	29	420	0.90	XW	1	71M2-6	15
37	61	23	420	1.14	XL	1	71M2-6	15
50	45	17	420	1.54				
77	29	11	420	2.38				
<hr/>								
38	60	17	420	1.17	XW	1	80M2-8	26
59	39	11	420	1.81	XL	1	80M2-8	26
72	32	9	420	2.21				

<b>P<sub>1</sub> = 0.37 kW</b>								
--------------------------------	--	--	--	--	--	--	--	--

1.4	2180	1003	7650	0.92				
1.7	1828	841	7650	1.09	XWE	63	71M2-4	155
1.9	1589	731	7650	1.26	XLE	63	71M2-4	155
2.3	1365	595	7650	1.47	BWE	2715	71M2-4	155
2.9	1085	473	7650	1.84	BLE	2715	71M2-4	155
4.4	732	319	7650	2.73				



技术参数

Technical Data

<b>P<sub>1</sub> = 0.37 kW</b>								
--------------------------------	--	--	--	--	--	--	--	--

N <sub>A</sub> rpm	M <sub>2</sub> Nm	i	Fr <sub>2MAX</sub> [N]	f <sub>s</sub>	Type	Gear unit	Motor size	Kg
52	64	17	420	1.09	XW	1	80M1-6	25
80	42	11	420	1.68	XL	1	80M1-6	25
98	9	34	420	2.05				

<b>P<sub>1</sub> = 0.55 kW</b>								
--------------------------------	--	--	--	--	--	--	--	--

1.9	2362	731	7650	0.85	XWE	63	80M1-4	165
2.3	2029	595	7650	0.99	XLE	63	80M1-4	165
2.9	1613	473	7650	1.24	BWE	2715	80M1-4	165
4.4	1088	319	7650	1.84	BLE	2715	80M1-4	165
4.8	985	289	7650	2.03				
4.4	1088	319	5660	0.92	XWE	53	80M1-4	111
4.8	985	289	5660	1.01	XLE	53	80M1-4	111
7.4	638	187	5660	1.57	BWE	2215	80M1-4	111
11.5	413	121	5660	2.42	BLE	2215	80M1-4	111
7.4	638	187	3960	0.78	XWE	42	80M1-4	92
11.5	413	121	3960	1.21	XLE	42	80M1-4	92
					BWE	1812	80M1-4	92
					BLE	1812	80M1-4	92
8	627	87	5660	1.59	XW	5	90L-8	119
9	512	71	5660	1.95	XL	5	90L-8	119
11	426	59	5660	2.35	BW	22	90L-8	119
					BL	22	90L-8	119
16	302	87	3960	1.65	XW	4	80M1-4	62
20	247	71	3960	2.03	XL	4	80M1-4	62
24	205	59	3960	2.44	BW	18	80M1-4	62
					BL	18	80M1-4	62
10	475	87	3960	1.05	XW	4	80M2-6	63
12	388	71	3960	1.29	XL	4	80M2-6	63
15	322	59	3960	1.55	BW	18	80M2-6	63
21	235	43	3960	2.13	BL	18	80M2-6	63
25	197	35	3960	2.53				
11	426	59	3960	1.18	XW	4	90L-8	72
16	310	43	3960	1.61	XL	4	90L-8	72
19	261	35	3960	1.92	BW	18	90L-8	72
23	216	29	3960	2.32	BL	18	90L-8	72
29	171	23	3960	2.92				
20	247	71	2550	1.01	XW	3	80M1-4	46
24	205	59	2550	1.22	XL	3	80M1-4	46
32	149	43	2550	1.67	BW	15	80M1-4	46
40	126	35	2550	1.99	BL	15	80M1-4	46
48	104	29	2550	2.40				



技术参数

Technical Data

<b>P<sub>1</sub> = 0.55 kW</b>								
--------------------------------	--	--	--	--	--	--	--	--

N <sub>A</sub> rpm	M <sub>2</sub> Nm	i	Fr <sub>2MAX</sub> [N]	f <sub>s</sub>	Type	Gear unit	Motor size	Kg
21	235	43	2550	1.06	XW XL BW BL	3 3 15 15	80M2-6	47
25	197	35	2550	1.27				
31	164	29	2550	1.53				
38	130	23	2550	1.93				
52	96	17	2550	2.61				
23	216	29	2550	1.16	XW	3	90L-8	56
29	171	23	2550	1.46	XL	3	90L-8	56
39	127	17	2550	1.97	BW	15	90L-8	56
					BL	15	90L-8	56
32	149	43	1900	1.00	XW XL BW BL	2 2 12 12	80M1-4	31
40	126	35	1900	1.19				
48	104	29	1900	1.44				
60	83	23	1900	1.82				
82	61	17	1900	2.46				
31	164	29	1900	0.92	XW	2	80M2-6	32
38	130	23	1900	1.16	XL	2	80M2-6	32
52	96	17	1900	1.56	BW	12	80M2-6	32
80	62	11	1900	2.42	BL	12	80M2-6	32
39	127	17	1900	1.18	XW	2	90L-8	48
61	82	11	1900	1.83	XL	2	90L-8	48
74	67	9	1900	2.24	BW	12	90L-8	48
					BL	12	90L-8	48
82	61	17	420	1.15	XW XL	1 1	80M1-4	25
126	39	11	420	1.77				
154	32	9	420	2.17				
77	65	11	420	1.08	XW	1	80M2-6	26
94	53	9	420	1.32	XL	1	80M2-6	26

<b>P<sub>1</sub> = 0.75 kW</b>								
--------------------------------	--	--	--	--	--	--	--	--

1.1	5397	1225	17460	0.83	XWE XLE BWE BLE	84 84 3318 3318	80M2-4	308
1.4	4419	1003	17460	1.02				
1.7	3705	841	17460	1.21				
1.9	3220	731	17460	1.40				
2.3	2767	595	17460	1.63				
2.9	2199	473	17460	2.05				
1.9	3220	731	10280	0.84	XWE XLE	74 74	80M2-4	211
2.3	2767	595	10280	0.98				
2.9	2199	473	10280	1.23				
4.4	1483	319	10280	1.82				
4.8	1344	289	10280	2.01				



技术参数

Technical Data

<b>P<sub>1</sub> = 0.75 kW</b>								
--------------------------------	--	--	--	--	--	--	--	--

N <sub>A</sub> rpm	M <sub>2</sub> Nm	i	Fr <sub>2MAX</sub> [N]	f <sub>s</sub>	Type	Gear unit	Motor size	Kg
40	170	17	2550	1.47	XW	3	100L1-8	63
62	110	11	2550	2.27	XL	3	100L1-8	63
76	90	9	2550	2.78	BW	15	100L1-8	63
					BL	15	100L1-8	63
40	171	35	1900	0.88	XW	2	80M2-4	32
48	142	29	1900	1.06	XL	2	80M2-4	32
60	113	23	1900	1.33	BW	12	80M2-4	32
82	83	17	1900	1.80	BL	12	80M2-4	32
52	131	17	1900	1.15	XW	2	90S-6	36
80	85	11	1900	1.77	XL	2	90S-6	36
98	69	9	1900	2.17	BW	12	90S-6	36
					BL	12	90S-6	36
126	54	11	420	1.30	XW	1	80M2-4	26
154	44	9	420	1.59	XL	1	80M2-4	26

<b>P<sub>1</sub> = 1.1 kW</b>								
-------------------------------	--	--	--	--	--	--	--	--

0.9	9655	1505	29100	0.93				
1.1	7859	1225	29100	1.15	XWE	95	90S-4	507
1.4	6435	1003	29100	1.40	XLE	95	90S-4	507
1.7	5395	841	29100	1.67	BWE	3922	90S-4	507
1.9	4690	731	29100	1.92	BLE	3922	90S-4	507
2.4	4029	595	29100	2.23				
1.7	5395	841	17460	0.83				
1.9	4690	731	17460	0.96	XWE	85	90S-4	332
2.4	4029	595	17460	1.12	XLE	85	90S-4	332
3.0	3203	473	17460	1.41	BWE	3322	90S-4	332
4.4	2160	319	17460	2.08	BLE	3322	90S-4	332
4.8	1957	289	17460	2.30				
1.7	5395	841	17460	0.83				
1.9	4690	731	17460	0.96	XWE	84	90S-4	292
2.4	4029	595	17460	1.12	XLE	84	90S-4	292
3.0	3203	473	17460	1.41	BWE	3318	90S-4	292
4.4	2160	319	17460	2.08	BLE	3318	90S-4	292
4.8	1957	289	17460	2.30				
3.0	3203	473	10280	0.84				
4.4	2160	319	10280	1.25	XWE	74	90S-4	215
4.8	1957	289	10280	1.38	XLE	74	90S-4	215
7.5	1266	187	10280	2.13				



技术参数

Technical Data

P <sub>1</sub> = 1.1 kW								
N <sub>A</sub> rpm	M <sub>2</sub> Nm	i	Fr <sub>2MAX</sub> [N]	f <sub>s</sub>	Type	Gear unit	Motor size	 Kg
4.4	2160	319	7650	0.93	XWE	63	90S-4	170
4.8	1957	289	7650	1.02	XLE	63	90S-4	170
7.5	1266	187	7650	1.58	BWE	2715	90S-4	170
11.6	819	121	7650	2.44	BLE	2715	90S-4	170
11.6	819	121	5660	1.22	XWE	53	90S-4	116
					XLE	53	90S-4	116
					BWE	2715	90S-4	116
					BLE	2715	90S-4	116
8	1237	87	10280	2.18	XW	7	100L2-8	199
10	1009	71	10280	2.68	XL	7	100L2-8	199
10	924	87	5660	1.08	XW	5	90L-6	119
13	754	71	5660	1.33	XL	5	90L-6	119
15	627	59	5660	1.60	BW	22	90L-6	119
21	457	43	5660	2.19	BL	22	90L-6	119
12	839	59	5660	1.19	XW	5	100L2-8	130
16	611	43	5660	1.64	XL	5	100L2-8	130
					BW	22	100L2-8	130
					BL	22	100L2-8	130
20	490	71	3960	1.02	XW	4	90S-4	67
24	407	59	3960	1.23	XL	4	90S-4	67
33	297	43	3960	1.68	BW	18	90S-4	67
40	249	35	3960	2.00	BL	18	90S-4	67
48	207	29	3960	2.42				
21	457	43	3960	1.09	XW	4	90L-6	72
26	384	35	3960	1.30	XL	4	90L-6	72
31	318	29	3960	1.57	BW	18	90L-6	72
40	252	23	3960	1.98	BL	18	90L-6	72
54	186	17	3960	2.68				
23	426	29	3960	1.17	XW	4	100L2-8	83
30	338	23	3960	1.48	XL	4	100L2-8	83
40	249	17	3960	2.00	BW	18	100L2-8	83
					BL	18	100L2-8	83
40	249	35	2550	1.00	XW	3	90S-4	51
48	207	29	2550	1.21	XL	3	90S-4	51
61	164	23	2550	1.52	BW	15	90S-4	51
82	121	17	2550	2.06	BL	15	90S-4	51
40	252	23	2550	0.99	XW	3	90L-6	56
54	186	17	2550	1.34	XL	3	90L-6	56
83	121	11	2550	2.07	BW	15	90L-6	56
101	99	9	2550	2.53	BL	15	90L-6	56



技术参数

Technical Data

<b>P<sub>1</sub> = 1.1 kW</b>								
-------------------------------	--	--	--	--	--	--	--	--

N <sub>A</sub> rpm	M <sub>2</sub> Nm	i	Fr <sub>2MAX</sub> [N]	f <sub>s</sub>	Type	Gear unit	Motor size	Kg
40	249	17	2550	1.00	XW	3	100L2-8	67
62	161	11	2550	1.55	XL	3	100L2-8	67
76	132	9	2550	1.89	BW	15	100L2-8	67
					BL	15	100L2-8	67
61	164	23	1900	0.91	XW	2	90S-4	36
82	121	17	1900	1.24	XL	2	90S-4	36
127	78	11	1900	1.91	BW	12	90S-4	36
156	64	9	1900	2.34	BL	12	90S-4	36

<b>P<sub>1</sub> = 1.5 kW</b>								
-------------------------------	--	--	--	--	--	--	--	--

0.9	13166	1505	39800	0.91				
1.1	10717	1225	39800	1.12	XWE	106	90L-4	677
1.4	8774	1003	39800	1.37	XLE	106	90L-4	677
1.7	7357	841	39800	1.63	BWE	4527	90L-4	677
1.9	6395	731	39800	1.88	BLE	4527	90L-4	677
2.4	5494	595	39800	2.18				
1.1	10717	1225	29100	0.84				
1.4	8774	1003	29100	1.03	XWE	95	90L-4	512
1.7	7357	841	29100	1.22	XLE	95	90L-4	512
1.9	6395	731	29100	1.41	BWE	3922	90L-4	512
2.4	5494	595	29100	1.64	BLE	3922	90L-4	512
3.0	4367	473	29100	2.06				
2.4	5494	595	17460	0.82				
3.0	4367	473	17460	1.03	XWE	85	90L-4	337
4.4	2946	319	17460	1.53	XLE	85	90L-4	337
4.8	2669	289	17460	1.69	BWE	3322	90L-4	337
7.5	1727	187	17460	2.61	BLE	3322	90L-4	337
2.4	5494	595	17460	0.82				
3.0	4367	473	17460	1.03	XWE	84	90L-4	297
4.4	2946	319	17460	1.53	XLE	84	90L-4	297
4.8	2669	289	17460	1.69	BWE	3318	90L-4	297
7.5	1727	187	17460	2.61	BLE	3318	90L-4	297
4.4	2946	319	10280	0.92				
4.8	2669	289	10280	1.01	XWE	74	90L-4	220
7.5	1727	187	10280	1.56	XLE	74	90L-4	220
11.6	1117	121	10280	2.42				
7.5	1727	187	7650	1.16	XWE	63	90L-4	175
11.6	1117	121	7650	1.79	XLE	63	90L-4	175
					BWE	2715	90L-4	175
					BLE	2715	90L-4	175



技术参数

Technical Data

P <sub>1</sub> = 1.5 kW								
N <sub>A</sub> rpm	M <sub>2</sub> Nm	i	Fr <sub>2MAX</sub> [N]	f <sub>s</sub>	Type	Gear unit	Motor size	 Kg
11.6	1117	121	5660	0.90	XWE	53	90L-4	121
					XLE	53	90L-4	121
					BWE	2215	90L-4	121
					BLE	2215	90L-4	121
11	1246	87	10280	2.17	XW	7	100L-6	203
13	1017	71	10280	2.65	XL	7	100L-6	203
8	1662	87	10280	1.62	XW	7	112M-8	208
10	1356	71	10280	1.99				
12	1127	59	10280	2.40				
11	1246	87	7650	1.60	XW	6	100L-6	169
13	1017	71	7650	1.97	XL	6	100L-6	169
16	845	59	7650	2.37	BW	27	100L-6	169
					BL	27	100L-6	169
16	819	87	5660	1.22	XW	5	90L-4	119
20	668	71	5660	1.50	XL	5	90L-4	119
24	555	59	5660	1.80	BW	22	90L-4	119
33	405	43	5660	2.47	BL	22	90L-4	119
16	845	59	5660	1.18	XW	5	100L-6	130
21	616	43	5660	1.62	XL	5	100L-6	130
26	518	35	5660	1.93	BW	22	100L-6	130
32	429	29	5660	2.33	BL	22	100L-6	130
16	821	43	5660	1.22	XW	5	112M-8	135
20	690	35	5660	1.45	XL	5	112M-8	135
24	572	29	5660	1.75	BW	22	112M-8	135
30	454	23	5660	2.20	BL	22	112M-8	135
24	555	59	3960	0.90	XW	4	90L-4	72
33	405	43	3960	1.24				
40	340	35	3960	1.47				
48	282	29	3960	1.77				
61	224	23	3960	2.24				
32	429	29	3960	1.17	XW	4	100L-6	83
40	340	23	3960	1.47	XL	4	100L-6	83
54	251	17	3960	1.99	BW	4	100L-6	83
					BL	4	100L-6	83
30	454	23	3960	1.10	XW	4	112M-8	88
41	335	17	3960	1.49	XL	4	112M-8	88
63	217	11	3960	2.30	BW	4	112M-8	88
77	178	9	3960	2.82	BL	4	112M-8	88



技术参数

Technical Data

<b>P<sub>1</sub> = 1.5 kW</b>								
-------------------------------	--	--	--	--	--	--	--	--

N <sub>A</sub> rpm	M <sub>2</sub> Nm	i	Fr <sub>2MAX</sub> [N]	f <sub>s</sub>	Type	Gear unit	Motor size	Kg
48	282	29	2550	0.89	XW	3	90L-4	56
61	224	23	2550	1.12	XL	3	90L-4	56
82	165	17	2550	1.51	BW	15	90L-4	56
127	107	11	2550	2.34	BL	15	90L-4	56
156	87	9	2550	2.86				
<hr/>								
54	254	17	2550	0.98	XW	3	100L-6	67
83	165	11	2550	1.52	XL	3	100L-6	67
101	135	9	2550	1.86	BW	15	100L-6	67
					BL	15	100L-6	67
<hr/>								
82	165	17	1900	0.91	XW	2	90L-4	41
127	107	11	1900	1.40	XL	2	90L-4	41
156	87	9	1900	1.71	BW	12	90L-4	41
					BL	12	90L-4	41

<b>P<sub>1</sub> = 2.2 kW</b>								
-------------------------------	--	--	--	--	--	--	--	--

1.4	12688	1003	39800	0.95	XWE	106	100L1-4	684
1.7	10639	841	39800	1.13	XLE	106	100L1-4	684
1.9	9247	731	39800	1.30	BWE	4527	100L1-4	684
2.4	7944	595	39800	1.51	BLE	4527	100L1-4	684
3.0	6315	473	39800	1.90				
<hr/>								
1.7	10639	841	29100	0.85				
1.9	9247	731	29100	0.97	XWE	95	100L1-4	519
2.4	7944	595	29100	1.13	XLE	95	100L1-4	519
3.0	6315	473	29100	1.43	BWE	3922	100L1-4	519
4.5	4259	319	29100	2.11	BLE	3922	100L1-4	519
4.9	3859	289	29100	2.33				
<hr/>								
4.5	4259	319	17460	1.06	XWE	85	100L1-4	344
4.9	3859	289	17460	1.17	XLE	85	100L1-4	344
7.6	2497	187	17460	1.80	BWE	3322	100L1-4	344
11.7	1616	121	17460	2.79	BLE	3322	100L1-4	344
<hr/>								
4.5	4259	319	17460	1.06	XWE	84	100L1-4	304
4.9	3859	289	17460	1.17	XLE	84	100L1-4	304
7.6	2497	187	17460	1.80	BWE	3318	100L1-4	304
11.7	1616	121	17460	2.79	BLE	3318	100L1-4	304
<hr/>								
7.6	2497	187	10280	1.08	XWE	74	100L1-4	227
11.7	1616	121	10280	1.67	XLE	74	100L1-4	227
<hr/>								
8	2369	87	17460	1.56	XW	8	132S-8	313
10	1933	71	17460	1.91	XL	8	132S-8	313
					BW	33	132S-8	313
					BL	33	132S-8	313



技术参数

Technical Data

P <sub>1</sub> = 2.2 kW								
N <sub>A</sub> rpm	M <sub>2</sub> Nm	i	Fr <sub>2MAX</sub> [N]	f <sub>s</sub>	Type	Gear unit	Motor size	 Kg
11	1789	87	10280	1.51	XW	7	112M-6	208
13	1460	71	10280	1.85				
16	1213	59	10280	2.23				
8	2369	87	10280	1.14	XW	7	132S-8	233
10	1933	71	10280	1.40				
12	1606	59	10280	1.68				
17	1171	43	10280	2.31				
20	984	35	10280	2.74	XL	7	132S-8	233
16	1184	87	7650	1.69	XW	6	100L1-4	165
20	966	71	7650	2.07	XL	6	100L1-4	165
24	803	59	7650	2.49	BW	27	100L1-4	165
					BL	27	100L1-4	165
11	1789	87	7650	1.12	XW	6	112M-6	174
13	1460	71	7650	1.37	XL	6	112M-6	174
16	1213	59	7650	1.65	BW	27	112M-6	174
22	884	43	7650	2.26	BL	27	112M-6	174
17	1171	43	7650	1.71	XW	6	132S-8	199
20	984	35	7650	2.03	XL	6	132S-8	199
24	815	29	7650	2.45	BW	27	132S-8	199
					BL	27	132S-8	199
24	803	59	5660	1.25	XW	5	100L1-4	126
33	585	43	5660	1.71	XL	5	100L1-4	126
41	492	35	5660	2.03	BW	22	100L1-4	126
49	408	29	5660	2.45	BL	22	100L1-4	126
22	884	43	5660	1.13	XW	5	112M-6	135
27	743	35	5660	1.35	XL	5	112M-6	135
32	616	29	5660	1.62	BW	22	112M-6	135
41	488	23	5660	2.05	BL	22	112M-6	135
20	984	35	5660	1.02	XW	5	132S-8	160
42	478	17	5660	2.09	XL	5	132S-8	160
24	815	29	5660	1.23	BW	22	132S-8	160
31	647	23	5660	1.55	BL	22	132S-8	160
41	492	35	3960	1.02	XW	4	100L1-4	79
49	408	29	3960	1.23	XL	4	100L1-4	79
62	323	23	3960	1.55	BW	18	100L1-4	79
84	239	17	3960	2.09	BL	18	100L1-4	79
41	488	23	3960	1.02	XW	4	112M-6	88
55	361	17	3960	1.39	XL	4	112M-6	88
85	234	11	3960	2.14	BW	18	112M-6	88
104	191	9	3960	2.62	BL	18	112M-6	88



技术参数

Technical Data

P <sub>1</sub> = 2.2 kW								
N <sub>A</sub> rpm	M <sub>2</sub> Nm	i	Fr <sub>2MAX</sub> [N]	f <sub>s</sub>	Type	Gear unit	Motor size	 Kg
84	239	17	2550	1.05	XW	3	100L1-4	63
129	155	11	2550	1.62	XL	3	100L1-4	63
158	127	9	2550	1.98	BW	15	100L1-4	63
					BL	15	100L1-4	63
12	1606	59	7650	1.25	XW	6	132S-8	199
					XL	6	132S-8	199
					BW	27	132S-8	199
					BL	27	132S-8	199
P <sub>1</sub> = 3.0 kW								
1.2	21131	1225	50400	0.95	XWE	117	100L2-4	1318
1.4	17302	1003	50400	1.16	XLE	117	100L2-4	1318
1.2	21131	1225	50400	0.95				
1.4	17302	1003	50400	1.16				
1.7	14507	841	50400	1.38	XWE	116	100L2-4	1270
1.9	12610	731	50400	1.59	XLE	116	100L2-4	1270
2.4	10833	595	50400	1.85	BWE	5527	100L2-4	1270
3.0	8612	473	50400	2.32	BLE	5527	100L2-4	1270
4.5	5808	319	50400	3.44				
1.7	14507	841	39800	0.83				
1.9	12610	731	39800	0.95	XWE	106	100L2-4	688
2.4	10833	595	39800	1.11	XLE	106	100L2-4	688
3.0	8612	473	39800	1.39	BWE	4527	100L2-4	688
4.5	5808	319	39800	2.07	BLE	4527	100L2-4	688
4.9	5262	289	39800	2.28				
2.4	10833	595	29100	0.83				
3.0	8612	473	29100	1.05	XWE	95	100L2-4	523
4.5	5808	319	29100	1.55	XLE	95	100L2-4	523
4.9	5262	289	29100	1.71	BWE	3922	100L2-4	523
7.6	3405	187	29100	2.64	BLE	3922	100L2-4	523
4.9	5262	289	17460	0.86	XWE	84	100L2-4	308
7.6	3405	187	17460	1.32	XLE	84	100L2-4	308
11.7	2203	121	17460	2.04	BWE	3318	100L2-4	308
					BLE	3318	100L2-4	308
7.6	3405	187	10280	0.79	XWE	74	100L2-4	231
11.7	2203	121	10280	1.23	XLE	74	100L2-4	231
11	2389	87	17460	1.55	XW	8	132S-6	313
14	1949	71	17460	1.90	XL	8	132S-6	313
					BW	33	132S-6	313
					BL	33	132S-6	313



技术参数

Technical Data

P <sub>1</sub> = 3.0 kW								
N <sub>A</sub> rpm	M <sub>2</sub> Nm	i	Fr <sub>2MAX</sub> [N]	f <sub>s</sub>	Type	Gear unit	Motor size	 Kg
8	3230	87	17460	1.15	XW	8	132M-8	326
10	2636	71	17460	1.40	XL	8	132M-8	326
12	2190	59	17460	1.69	BW	33	132M-8	326
					BL	33	132M-8	326
16	1615	87	10280	1.67	XW	7	100L1-4	199
20	1318	71	10280	2.05	XL	7	100L1-4	199
24	1095	59	10280	2.47				
11	2389	87	10280	1.13				
14	1949	71	10280	1.39	XW	7	132S-6	233
16	1620	59	10280	1.67	XL	7	132S-6	233
22	1181	43	10280	2.29				
12	2190	59	10280	1.23				
17	1596	43	10280	1.69	XW	7	132M-8	246
20	1342	35	10280	2.01	XL	7	132M-8	246
24	1112	29	10280	2.43				
16	1615	87	7650	1.24	XW	6	100L2-4	169
20	1318	71	7650	1.52	XL	6	100L2-4	169
24	1095	59	7650	1.83	BW	27	100L2-4	169
33	798	43	7650	2.51	BL	27	100L2-4	169
16	1620	59	7650	1.23	XW	6	132S-6	199
22	1181	43	7650	1.69	XL	6	132S-6	199
27	992	35	7650	2.02	BW	27	132S-6	199
33	822	29	7650	2.43	BL	27	132S-6	199
17	1596	43	7650	1.25	XW	6	132M-8	212
20	1342	35	7650	1.49	XL	6	132M-8	212
24	1112	29	7650	1.80	BW	6	132M-8	212
31	882	23	7650	2.27	BL	6	132M-8	212
33	798	43	5660	1.25	XW	5	100L2-4	130
41	671	35	5660	1.49	XL	5	100L2-4	130
49	556	29	5660	1.80	BW	22	100L2-4	130
62	441	23	5660	2.27	BL	22	100L2-4	130
32	840	29	5660	1.19	XW	5	132S-6	160
41	666	23	5660	1.50	XL	5	132S-6	160
55	492	17	5660	2.03	BW	22	132S-6	160
					BL	22	132S-6	160
31	882	23	5660	1.13	XW	5	132M-8	173
42	652	17	5660	1.53	XL	5	132M-8	173
65	422	11	5660	2.37	BW	22	132M-8	173
					BL	22	132M-8	173



技术参数

Technical Data

<b>P<sub>1</sub> = 3.0 kW</b>								
-------------------------------	--	--	--	--	--	--	--	--

N <sub>A</sub> rpm	M <sub>2</sub> Nm	i	Fr <sub>2MAX</sub> [N]	f <sub>s</sub>	Type	Gear unit	Motor size	Kg
62	441	23	3960	1.13	XW	4	100L2-4	83
84	326	17	3960	1.53	XL	4	100L2-4	83
129	211	11	3960	2.37	BW	18	100L2-4	83
158	173	9	3960	2.90	BL	18	100L2-4	83

<b>P<sub>1</sub> = 4.0 kW</b>								
-------------------------------	--	--	--	--	--	--	--	--

1.4	22749	1003	50400	0.88				
1.7	19074	841	50400	1.05	XWE	117	112M-4	1323
2.0	16579	731	50400	1.21	XLE	117	112M-4	1323
2.4	14244	595	50400	1.40				
3.0	11323	473	50400	1.77				
1.4	22749	1003	50400	0.88	XWE	116	112M-4	1275
1.7	19074	841	50400	1.05	XLE	116	112M-4	1275
2.0	16579	731	50400	1.21	BWE	5527	112M-4	1275
2.4	14244	595	50400	1.40	BLE	5527	112M-4	1275
3.0	11323	473	50400	1.77				
4.5	7637	319	50400	2.62				
2.4	14244	595	39800	0.84	XWE	106	112M-4	693
3.0	11323	473	39800	1.06	XLE	106	112M-4	693
4.5	7637	319	39800	1.57	BWE	4527	112M-4	693
5.0	6918	289	39800	1.73	BLE	4527	112M-4	693
7.7	4477	187	39800	2.68				
4.5	7637	319	29100	1.18	XWE	95	112M-4	528
5.0	6918	289	29100	1.30	XLE	95	112M-4	528
7.7	4477	187	29100	2.01	BWE	3922	112M-4	528
7.7	4477	187	17460	1.01	BLE	3922	112M-4	353
11.9	2897	121	17460	1.55				
17	2123	87	29100	2.68	XW	9	112M-4	433
					XL	9	112M-4	433
					BW	39	112M-4	433
					BL	39	112M-4	433
11	3185	87	29100	1.79	XW	9	132M1-6	471
14	2599	71	29100	2.19	XL	9	132M1-6	471
16	2160	59	29100	2.64	BW	39	132M1-6	471
					BL	39	132M1-6	471
8	4306	87	29100	1.32	XW	9	160M1-8	513
10	3514	71	29100	1.62	XL	9	160M1-8	513
12	2920	59	29100	1.95	BW	39	160M1-8	513
17	2128	43	29100	2.68	BL	39	160M1-8	513



技术参数

Technical Data

P <sub>1</sub> = 4.0 kW								
N <sub>A</sub> rpm	M <sub>2</sub> Nm	i	Fr <sub>2</sub> MAX[N]	f <sub>s</sub>	Type	Gear unit	Motor size	 Kg
17	2123	87	17460	1.74	XW	8	112M-4	288
20	1733	71	17460	2.14	XL	8	112M-4	288
					BW	33	112M-4	288
					BL	33	112M-4	288
11	3185	87	17460	1.16	XW	8	132M1-6	326
14	2599	71	17460	1.42	XL	8	132M1-6	326
16	2160	59	17460	1.71	BW	33	132M1-6	326
					BL	33	132M1-6	326
8	4247	87	17460	0.87	XW	8	160M1-8	368
10	3466	71	17460	1.07	XL	8	160M1-8	368
12	2880	59	17460	1.28	BW	33	160M1-8	368
17	2099	43	17460	1.76	BL	33	160M1-8	368
21	1764	35	17460	2.10				
17	2123	87	10280	1.27	XW	7	112M-4	208
20	1733	71	10280	1.56	XL	7	112M-4	208
24	1440	59	10280	1.88				
33	1049	43	10280	2.57				
16	2160	59	10280	1.25	XW	7	132M1-6	246
22	1574	43	10280	1.72	XL	7	132M1-6	246
27	1323	35	10280	2.04				
33	1096	29	10280	2.46				
17	2099	43	10280	1.29	XW	7	160M1-8	283
21	1764	35	10280	1.53	XL	7	160M1-8	283
25	1462	29	10280	1.85				
31	1159	23	10280	2.33				
20	1733	71	7650	1.15	XW	6	112M-4	174
24	1440	59	7650	1.39	XL	6	112M-4	174
33	1049	43	7650	1.91	BW	27	112M-4	174
41	882	35	7650	2.27	BL	27	112M-4	174
16	2160	59	7650	0.93	XW	6	132M1-6	212
22	1574	43	7650	1.27	XL	6	132M1-6	212
27	1323	35	7650	1.51	BW	27	132M1-6	212
33	1096	29	7650	1.82	BL	27	132M1-6	212
42	869	23	7650	2.30				
21	1764	35	7650	1.13	XW	6	160M1-8	249
25	1462	29	7650	1.37	XL	6	160M1-8	249
31	1159	23	7650	1.73	BW	27	160M1-8	249
42	857	17	7650	2.33	BL	27	160M1-8	249



技术参数

Technical Data

<b>P<sub>1</sub> = 4.0 kW</b>								
-------------------------------	--	--	--	--	--	--	--	--

N <sub>A</sub> rpm	M <sub>2</sub> Nm	i	Fr <sub>2MAX</sub> [N]	f <sub>s</sub>	Type	Gear unit	Motor size	Kg
33	1049	43	5660	0.95	XW	5	112M-4	135
41	882	35	5660	1.13				
50	731	29	5660	1.37				
63	580	23	5660	1.73				
85	428	17	5660	2.33				
33	1096	29	5660	0.91	XW	5	132M1-6	165
42	869	23	5660	1.15	XL	5	132M1-6	165
56	643	17	5660	1.56	BW	22	132M1-6	165
87	416	11	5660	2.40	BL	22	132M1-6	165
42	857	17	5660	1.17	XW	5	160M1-8	210
65	554	11	5660	1.80	XL	5	160M1-8	210
80	454	9	5660	2.20	BW	22	160M1-8	210
					BL	22	160M1-8	210
84	434	17	3960	1.15	XW	4	112M-4	88
129	281	11	3960	1.78	XL	4	112M-4	88
158	230	9	3960	2.17	BW	18	112M-4	88
					BL	18	112M-4	88

<b>P<sub>1</sub> = 5.5 kW</b>								
-------------------------------	--	--	--	--	--	--	--	--

2.0	22797	731	50400	0.88	XWE	117	132S-4	1348
2.4	19585	595	50400	1.02				
3.0	15569	473	50400	1.28				
4.5	10500	319	50400	1.90				
5.0	9513	289	50400	2.10				
2.0	22797	731	50400	0.88	XWE	116	132S-4	1300
2.4	19585	595	50400	1.02	XLE	116	132S-4	1300
3.0	15569	473	50400	1.28	BWE	5527	132S-4	1300
4.5	10500	319	50400	1.90	BLE	5527	132S-4	1300
5.0	9513	289	50400	2.10				
4.5	10500	319	39800	1.14	XWE	106	132S-4	718
5.0	9513	289	39800	1.26	XLE	106	132S-4	718
7.7	6155	187	39800	1.95	BWE	4527	132S-4	718
					BLE	4527	132S-4	718
4.5	10500	319	29100	0.86	XWE	95	132S-4	553
5.0	9513	289	29100	0.95	XLE	95	132S-4	553
7.7	6155	187	29100	1.46	BWE	3922	132S-4	553
11.9	3983	121	29100	2.26	BLE	3922	132S-4	553
11.7	4039	121	17460	1.11				



技术参数

Technical Data

P <sub>1</sub> = 5.5 kW								
N <sub>A</sub> rpm	M <sub>2</sub> Nm	i	Fr <sub>2MAX</sub> [N]	f <sub>s</sub>	Type	Gear unit	Motor size	 Kg
17	2920	87	29100	1.95	XW	9	132S-4	458
20	2383	71	29100	2.39	XL	9	132S-4	458
24	1980	59	29100	2.88	BW	39	132S-4	458
					BL	39	132S-4	458
11	4379	87	29100	1.30	XW	9	132M2-6	474
14	3574	71	29100	1.59	XL	9	132M2-6	474
16	2970	59	29100	1.92	BW	39	132M2-6	474
22	2164	43	29100	2.63	BL	39	132M2-6	474
10	4765	71	29100	1.20	XW	9	160M2-8	509
12	3960	59	29100	1.44	XL	9	160M2-8	509
17	2886	43	29100	1.98	BW	39	160M2-8	509
21	2426	35	29100	2.35	BL	39	160M2-8	509
25	2010	29	29100	2.84				
17	2920	87	17460	1.27	XW	8	132S-4	313
20	2383	71	17460	1.55	XL	8	132S-4	313
24	1980	59	17460	1.87	BW	33	132S-4	313
					BL	33	132S-4	313
11	4379	87	17460	0.84	XW	8	132M2-6	329
14	3574	71	17460	1.04	XL	8	132M2-6	329
16	2970	59	17460	1.25	BW	33	132M2-6	329
22	2164	43	17460	1.71	BL	33	132M2-6	329
27	1819	35	17460	2.03				
12	3960	59	17460	0.93	XW	8	160M2-8	364
17	2886	43	17460	1.28	XL	8	160M2-8	364
21	2426	35	17460	1.53	BW	33	160M2-8	364
25	2010	29	17460	1.84	BL	33	160M2-8	364
20	2383	71	10280	1.13	XW	7	132S-4	233
24	1980	59	10280	1.36	XL	7	132S-4	233
33	1443	43	10280	1.87				
41	1213	35	10280	2.23				
50	1005	29	10280	2.69				
11	4379	87	10280	0.62	XW	7	132M2-6	249
14	3574	71	10280	0.76	XL	7	132M2-6	249
16	2970	59	10280	0.91				
22	2164	43	10280	1.25				
27	1819	35	10280	1.48				
33	1507	29	10280	1.79				
42	1195	23	10280	2.26				
56	884	17	10280	3.06				
87	572	11	10280	4.72				



技术参数

Technical Data

P <sub>1</sub> = 7.5 kW								
N <sub>A</sub> rpm	M <sub>2</sub> Nm	i	Fr <sub>2</sub> MAX[N]	f <sub>s</sub>	Type	Gear unit	Motor size	 Kg
3.1	20940	473	50400	0.96	XW	116	132M-4	1313
4.6	14122	319	50400	1.42	XL	116	132M-4	1313
5.1	12794	289	50400	1.56	BW	5527	132M-4	1313
7.8	8279	187	50400	2.42	BL	5527	132M-4	1313
4.6	14122	319	39800	0.85	XW	106	132M-4	731
5.1	12794	289	39800	0.94	XL	106	132M-4	731
7.8	8279	187	39800	1.45	BW	4527	132M-4	731
12.1	5357	121	39800	2.24	BL	4527	132M-4	731
7.7	8394	187	29100	1.07	XW	95	132M-4	553
11.9	5431	121	29100	1.66	XL	95	132M-4	553
					BW	3922	132M-4	553
					BL	3922	132M-4	553
8	7962	87	39800	1.51	XW	10	160L-8	709
10	6498	71	39800	1.85	XL	10	160L-8	709
12	5400	59	39800	2.22	BW	45	160L-8	709
					BL	45	160L-8	709
16	4050	59	29100	1.41	XW	9	160M-6	509
22	2952	43	29100	1.93	XL	9	160M-6	509
27	2481	35	29100	2.30	BW	39	160M-6	509
33	2055	29	29100	2.77	BL	39	160M-6	509
12	5400	59	29100	1.06	XW	9	160L-8	535
17	3935	43	29100	1.45	XL	9	160L-8	535
21	3308	35	29100	1.72	BW	39	160L-8	535
25	2741	29	29100	2.08	BL	39	160L-8	535
31	2174	23	29100	2.62				
17	3927	87	17460	0.94	XW	8	132M-4	326
21	3204	71	17460	1.15	XL	8	132M-4	326
25	2663	59	17460	1.39	BW	33	132M-4	326
34	1941	43	17460	1.91	BL	33	132M-4	326
22	2952	43	17460	1.25	XW	8	160M-6	364
27	2481	35	17460	1.49	XL	8	160M-6	364
33	2055	29	17460	1.80	BW	33	160M-6	364
					BL	33	132M-4	326
17	3935	43	17460	0.94	XW	8	160L-8	390
21	3308	35	17460	1.12	XL	8	160L-8	390
25	2741	29	17460	1.35	BW	33	160L-8	390
31	2174	23	17460	1.70	BL	33	160L-8	390



技术参数

Technical Data

P <sub>1</sub> = 7.5 kW								
N <sub>A</sub> rpm	M <sub>2</sub> Nm	i	Fr <sub>2MAX</sub> [N]	f <sub>s</sub>	Type	Gear unit	Motor size	 Kg
25	2663	59	10280	1.01				
34	1941	43	10280	1.39	XW	7	132M-4	246
42	1631	35	10280	1.66	XL	7	132M-4	246
50	1352	29	10280	2.00				
63	1072	23	10280	2.52				
27	2481	35	10280	1.09				
33	2055	29	10280	1.31	XW	7	160M-6	284
42	1630	23	10280	1.66	XL	7	160M-6	284
56	1205	17	10280	2.24				
25	2741	29	10280	0.99				
31	2174	23	10280	1.24	XW	7	160L-8	310
42	1607	17	10280	1.68	XL	7	160L-8	310
65	1040	11	10280	2.60				
34	1941	43	7650	1.03	XW	6	132M-4	212
42	1631	35	7650	1.23	XL	6	132M-4	212
50	1352	29	7650	1.48	BW	27	132M-4	212
63	1072	23	7650	1.87	BL	27	132M-4	212
86	792	17	7650	2.52				
27	2481	35	7650	0.81				
33	2055	29	7650	0.97	XW	6	160M-6	250
42	1630	23	7650	1.23	XL	6	160M-6	250
56	1205	17	7650	1.66	BW	27	160M-6	250
87	780	11	7650	2.57	BL	27	160M-6	250
31	2174	23	7650	0.92				
42	1607	17	7650	1.24	XW	6	160L-8	276
65	1040	11	7650	1.92	XL	6	160L-8	276
80	851	9	7650	2.35	BW	27	160L-8	276
					BL	27	160L-8	276
63	1072	23	5660	0.93				
86	792	17	5660	1.26	XW	5	132M-4	173
133	513	11	5660	1.95	XL	5	132M-4	173
162	419	9	5660	2.38	BW	22	132M-4	173
					BL	22	132M-4	173
87	780	11	5660	1.28				
107	638	9	5660	1.57	XW	5	160M-6	211
					XL	5	160M-6	211
					BW	22	160M-6	211
					BL	22	160M-6	211



技术参数

Technical Data

P <sub>1</sub> = 11 kW								
N <sub>A</sub> rpm	M <sub>2</sub> Nm	i	Fr <sub>2</sub> MAX[N]	f <sub>s</sub>	Type	Gear unit	Motor size	 Kg
4.6	20713	319	50400	0.97				
5.1	18765	289	50400	1.07	XWE	117	160M-4	1403
7.8	12142	187	50400	1.65	XLE	117	160M-4	1403
12.1	7857	121	50400	2.55				
4.6	20713	319	50400	0.97	XWE	116	160M-4	1355
5.1	18765	289	50400	1.07	XLE	116	160M-4	1355
7.8	12142	187	50400	1.65	BWE	5527	160M-4	1355
12.1	7857	121	50400	2.55	BLE	5527	160M-4	1355
7.8	12142	187	39800	0.99	XWE	106	160M-4	773
12.1	7857	121	39800	1.53	XLE	106	160M-4	773
					BWE	4527	160M-4	773
					BLE	4527	160M-4	773
8	11518	87	50400	1.48	XW	11	180L-8	1355
10	9400	71	50400	1.81	XL	11	180L-8	1355
12	7811	59	50400	2.18	BW	55	180L-8	1355
17	5693	43	50400	2.99	BL	55	180L-8	1355
17	5759	87	39800	2.08	XW	10	160M-4	687
21	4700	71	39800	2.55	XL	10	160M-4	687
					BW	45	160M-4	687
					BL	45	160M-4	687
11	8759	87	39800	1.37	XW	10	160L-6	711
14	7148	71	39800	1.68	XL	10	160L-6	711
16	5940	59	39800	2.02	BW	45	160L-6	711
22	4329	43	39800	2.77	BL	45	160L-6	711
8	11518	87	39800	1.04	XW	10	180L-8	748
10	9400	71	39800	1.28	XL	10	180L-8	748
12	7811	59	39800	1.54	BW	45	180L-8	748
17	5693	43	39800	2.11	BL	45	180L-8	748
21	4785	35	39800	2.51				
25	3906	59	29100	1.46	XW	9	160M-4	513
34	2846	43	29100	2.00	XL	9	160M-4	513
42	2392	35	29100	2.38	BW	39	160M-4	513
					BL	39	160M-4	513
16	5940	59	29100	0.96	XW	9	160L-6	537
22	4329	43	29100	1.32	XL	9	160L-6	537
27	3638	35	29100	1.57	BW	39	160L-6	537
33	3015	29	29100	1.89	BL	39	160L-6	537
42	2391	23	29100	2.38				



技术参数

Technical Data

P <sub>1</sub> = 11 kW								
N <sub>A</sub> rpm	M <sub>2</sub> Nm	i	Fr <sub>2</sub> MAX[N]	f <sub>s</sub>	Type	Gear unit	Motor size	 Kg
21	4785	35	29100	1.19	XW	9	180L-8	535
25	3965	29	29100	1.44	XL	9	180L-8	535
32	3144	23	29100	1.81	BW	39	180L-8	535
43	2324	17	29100	2.45	BL	39	180L-8	535
34	2846	43	17460	1.30	XW	8	160M-4	368
42	2392	35	17460	1.55	XL	8	160M-4	368
50	1982	29	17460	1.87	BW	33	160M-4	368
					BL	33	160M-4	368
22	4329	43	17460	0.85	XW	8	160L-6	392
27	3638	35	17460	1.02	XL	8	160L-6	392
33	3015	29	17460	1.23	BW	33	160L-6	392
42	2391	23	17460	1.55	BL	33	160L-6	392
56	1767	17	17460	2.09				
25	3965	29	17460	0.93	XW	8	180L-8	429
32	3144	23	17460	1.18	XL	8	180L-8	429
43	2324	17	17460	1.59	BW	33	180L-8	429
66	1504	11	17460	2.46	BL	33	180L-8	429
42	2392	35	10280	1.13				
50	1982	29	10280	1.36	XW	7	160M-4	288
63	1572	23	10280	1.72	XL	7	160M-4	288
86	1162	17	10280	2.32				
33	3015	29	10280	0.90				
42	2391	23	10280	1.13	XW	7	160L-6	312
56	1767	17	10280	1.53	XL	7	160L-6	312
87	1144	11	10280	2.36				
50	1982	29	7650	1.01	XW	6	160M-4	254
63	1572	23	7650	1.27	XL	6	160M-4	254
86	1162	17	7650	1.72	BW	27	160M-4	254
					BL	27	160M-4	254
42	2391	23	7650	0.84	XW	6	160L-6	278
56	1767	17	7650	1.13	XL	6	160L-6	278
87	1144	11	7650	1.75	BW	27	160L-6	278
107	936	9	7650	2.14	BL	27	160L-6	278
133	752	11	5660	1.33	XW	5	160M-4	215
					XL	5	160M-4	215
162	615	9	5660	1.63	BW	22	160M-4	215
					BL	22	160M-4	215



技术参数

Technical Data

P <sub>1</sub> = 15 kW								
N <sub>A</sub> rpm	M <sub>2</sub> Nm	i	Fr <sub>2</sub> MAX[N]	f <sub>s</sub>	Type	Gear unit	Motor size	 Kg
7.8	16557	187	50400	1.21	XW	117	160L-4	1424
12.1	10713	121	50400	1.87	XL	117	160L-4	1424
7.8	16557	187	50400	1.21	XW	116	160L-4	1376
12.1	10713	121	50400	1.87	XL	116	160L-4	1376
					BW	5527	160L-4	1376
					BL	5527	160L-4	1376
11	11820	87	50400	1.44	XW	11	180L-6	1355
14	9646	71	50400	1.76	XL	11	180L-6	1355
16	8016	59	50400	2.12	BW	55	180L-6	1355
					BL	55	180L-6	1355
10	12818	71	50400	1.33	XW	11	200L-8	1410
12	10652	59	50400	1.60	XL	11	200L-8	1410
17	7763	43	50400	2.19	BW	55	200L-8	1410
21	6525	35	50400	2.61	BL	55	200L-8	1410
17	7853	87	39800	1.53	XW	10	160L-4	708
21	6409	71	39800	1.87	XL	10	160L-4	708
25	5326	59	39800	2.25	BW	45	160L-4	708
					BL	45	160L-4	708
16	8016	59	39800	1.50	XW	10	180L-6	759
23	5842	43	39800	2.05	XL	10	180L-6	759
28	4910	35	39800	2.44	BW	45	180L-6	759
					BL	45	180L-6	759
17	7763	43	39800	1.55	XW	10	200L-8	814
21	6525	35	39800	1.84	XL	10	200L-8	814
25	5406	29	39800	2.22	BW	45	200L-8	814
					BL	45	200L-8	814
34	3881	43	29100	1.47	XW	9	160L-4	534
42	3262	35	29100	1.75	XL	9	160L-4	534
50	2703	29	29100	2.11	BW	39	160L-4	534
63	2144	23	29100	2.66	BL	39	160L-4	534
28	4910	35	29100	1.16	XW	9	180L-6	585
33	4069	29	29100	1.40	XL	9	180L-6	585
42	3227	23	29100	1.77	BW	39	180L-6	585
57	2385	17	29100	2.39	BL	39	180L-6	585
32	4288	23	29100	1.33	XW	9	200L-8	640
43	3169	17	29100	1.80	XL	9	200L-8	640
					BW	39	200L-8	640
					BL	39	200L-8	640



技术参数

Technical Data

P <sub>1</sub> = 15 kW								
N <sub>A</sub> rpm	M <sub>2</sub> Nm	i	Fr <sub>2</sub> MAX[N]	f <sub>s</sub>	Type	Gear unit	Motor size	 Kg
34	3881	43	17460	0.95	XW	8	160L-4	389
42	3262	35	17460	1.13	XL	8	160L-4	389
50	2703	29	17460	1.37	BW	33	160L-4	389
63	2144	23	17460	1.73	BL	33	160L-4	389
86	1585	17	17460	2.34				
					XW	8	180L-6	440
33	4069	29	17460	0.91	XL	8	180L-6	440
42	3227	23	17460	1.15	BW	33	180L-6	440
57	2385	17	17460	1.55	BL	33	180L-6	440
					XW	8	200L-8	495
32	4288	23	17460	0.86	XL	8	200L-8	495
43	3169	17	17460	1.17	BW	33	200L-8	495
66	2051	11	17460	1.80	BL	33	200L-8	495
					XW	7	160L-4	309
50	2703	29	10280	1.00	XL	7	160L-4	309
63	2144	23	10280	1.26				
86	1585	17	10280	1.70				
133	1025	11	10280	2.63				
					XW	6	160L-4	275
63	2144	23	7650	0.93	XL	6	160L-4	275
86	1585	17	7650	1.26	BW	33	160L-4	275
133	1025	11	7650	1.95	BL	33	160L-4	275
162	839	9	7650	2.38				
P <sub>1</sub> = 18.5 kW								
14	11897	71	50400	1.43	XW	11	200L1-6	1380
16	9887	59	50400	1.72	XL	11	200L1-6	1380
23	7205	43	50400	2.36	BW	55	200L1-6	1380
28	6056	35	50400	2.81	BL	55	200L1-6	1380
					XW	11	225S-8	1426
12	13137	59	50400	1.29	XL	11	225S-8	1426
17	9574	43	50400	1.78	BW	55	225S-8	1426
21	8047	35	50400	2.11	BL	55	225S-8	1426
25	6668	29	50400	2.55				
					XW	10	200L1-6	784
23	7205	43	39800	1.67	XL	10	200L1-6	784
28	6056	35	39800	1.98	BW	45	200L1-6	784
33	5018	29	39800	2.39	BL	45	200L1-6	784
					XW	10	225S-8	830
21	8047	35	39800	1.49	XL	10	225S-8	830
25	6668	29	39800	1.80	BW	45	225S-8	830
32	5288	23	39800	2.27	BL	45	225S-8	830



技术参数

Technical Data

<b>P<sub>1</sub> = 18.5 kW</b>								
--------------------------------	--	--	--	--	--	--	--	--

N <sub>A</sub> rpm	M <sub>2</sub> Nm	i	Fr <sub>2MAX</sub> [N]	f <sub>s</sub>	Type	Gear unit	Motor size	Kg
33	5018	29	29100	1.14	XW	9	200L1-6	610
42	3980	23	29100	1.43	XL	9	200L1-6	610
57	2942	17	29100	1.94	BW	39	200L1-6	610
88	1903	11	29100	2.99	BL	39	200L1-6	610
42	3980	23	17460	0.93	XW	8	200L1-6	465
57	2942	17	17460	1.26	XL	8	200L1-6	465
88	1903	11	17460	1.94	BW	33	200L1-6	465
					BL	33	200L1-6	465

<b>P<sub>1</sub> = 22 kW</b>								
------------------------------	--	--	--	--	--	--	--	--

16	11757	59	50400	1.45	XW	11	200L2-6	1410
23	8569	43	50400	1.98	XL	11	200L2-6	1410
28	7202	35	50400	2.36	BW	55	200L2-6	1410
					BL	55	200L2-6	1410
17	11232	43	50400	1.51	XW	11	225M-8	1452
21	9440	35	50400	1.80	XL	11	225M-8	1452
26	7822	29	50400	2.17	BW	55	225M-8	1452
32	6204	23	50400	2.74	BL	55	225M-8	1452
23	8569	43	39800	1.40	XW	10	200L2-6	814
28	7202	35	39800	1.67	XL	10	200L2-6	814
33	5967	29	39800	2.01	BW	45	200L2-6	814
42	4733	23	39800	2.54	BL	45	200L2-6	814
26	7822	29	39800	1.53	XW	10	225M-8	856
32	6204	23	39800	1.93	XL	10	225M-8	856
44	4585	17	39800	2.62	BW	45	225M-8	856
					BL	45	225M-8	856

<b>P<sub>1</sub> = 30 kW</b>								
------------------------------	--	--	--	--	--	--	--	--

23	11565	43	50400	1.47	XW	11	225M-6	1452
28	9721	35	50400	1.75	XL	11	225M-6	1452
34	8054	29	50400	2.11	BW	55	225M-6	1452
43	6388	23	50400	2.66	BL	55	225M-6	1452
21	12873	35	50400	1.32	XW	11	Y250M-8	1565
26	10666	29	50400	1.59	XL	11	Y250M-8	1565
32	8459	23	50400	2.01	BW	55	Y250M-8	1565
44	6253	17	50400	2.72	BL	55	Y250M-8	1565



技术参数

Technical Data

<b>P<sub>1</sub> = 30kW</b>								
-----------------------------	--	--	--	--	--	--	--	--

N <sub>A</sub> rpm	M <sub>2</sub> Nm	i	Fr <sub>2MAX</sub> [N]	f <sub>s</sub>	Type	Gear unit	Motor size	Kg
34	8054	29	39800	1.49	XW XL BW BL	10 10 45 45	225M-6 225M-6 225M-6 225M-6	856 856 969 969
43	6388	23	39800	1.88				
32	8459	23	39800	1.42				
44	6253	17	39800	1.92				
67	4046	11	39800	2.97				

<b>P<sub>1</sub> = 37kW</b>								
-----------------------------	--	--	--	--	--	--	--	--

28	11989	35	50400	1.42	XW XL BW BL	11 11 55 55	250M-6 250M-6 250M-6 250M-6	1452 1452 1452 1452
34	9933	29	50400	1.71				
43	7878	23	50400	2.16				
43	7878	23	50400	2.16				
26	13155	29	50400	1.29	XW XL BW BL	11 11 55 55	280S-8 280S-8 280S-8 280S-8	1680 1680 1680 1680
32	10433	23	50400	1.63				
44	7712	17	50400	2.20				
44	7712	17	50400	2.20				
43	7878	23	39800	1.52	XW XL BW BL	10 10 45 45	250M-6 250M-6 250M-6 250M-6	972 972 972 972
58	5823	17	39800	2.06				
89	3768	11	39800	3.18				
89	3768	11	39800	3.18				
32	10433	23	39800	1.15	XW XL BW BL	10 10 45 45	280S-8 280S-8 280S-8 280S-8	1084 1084 1084 1084
44	7712	17	39800	1.56				
67	4990	11	39800	2.40				
67	4990	11	39800	2.40				

<b>P<sub>1</sub> = 45kW</b>								
-----------------------------	--	--	--	--	--	--	--	--

34	12081	29	50400	1.41	XW XL BW BL	11 11 55 55	280S-6 280S-6 280S-6 280S-6	1696 1696 1696 1696
43	9582	23	50400	1.77				
58	7082	17	50400	2.40				
89	4583	11	50400	3.71				
26	15999	29	50400	1.06	XW XL BW BL	11 11 55 55	280M-8 280M-8 280M-8 280M-8	1752 1752 1752 1752
32	12689	23	50400	1.34				
44	9379	17	50400	1.81				
67	6069	11	50400	2.80				
43	9582	23	39800	1.25	XW XL BW BL	10 10 45 45	280S-6 280S-6 280S-6 280S-6	1100 1100 1100 1100
58	7082	17	39800	1.69				
89	4583	11	39800	2.62				
89	4583	11	39800	2.62				



技术参数

Technical Data

P <sub>1</sub> = 55kW								
N <sub>A</sub> rpm	M <sub>2</sub> Nm	i	Fr <sub>2MAX</sub> [N]	f <sub>s</sub>	Type	Gear unit	Motor size	 Kg
58 89	8656 5601	17 11	50400 50400	1.96 3.04	XW	11	280M-6	1755
					XL	11	280M-6	1755
					BW	55	280M-6	1755
					BL	55	280M-6	1755

各系列机型技术参数对照表

Comparison Table for different standards gear unit

我公司可以提供不同标准的同类减速机，其技术参数对应下标查找，需要安装尺寸，请联系本公司

SGR company can supply different standards, following table shown the comparison size, ask for SGR for the drawing and more details.

标准/standards		机型号/size											
行业标准 / trade standard	Z	1	2	3	4	5	6	7	8	9	10	11	
天津标准 / Tianjing standard	X	1	2	3	4	5	6	7	8	9	10	11	
机械部标准 / Ministry of machine-buidling standard	B	10	12	15	18	22	27		33	39	45	55	
化工部标准 / chemical ministry standard	B		0	1	2	3	4		5	6	7	8	
上海标准 / Shanghai standard	B	09	10	11	12	13	14		15	16	17	18	



安装尺寸

Mounting Dimensions

**XW1..**

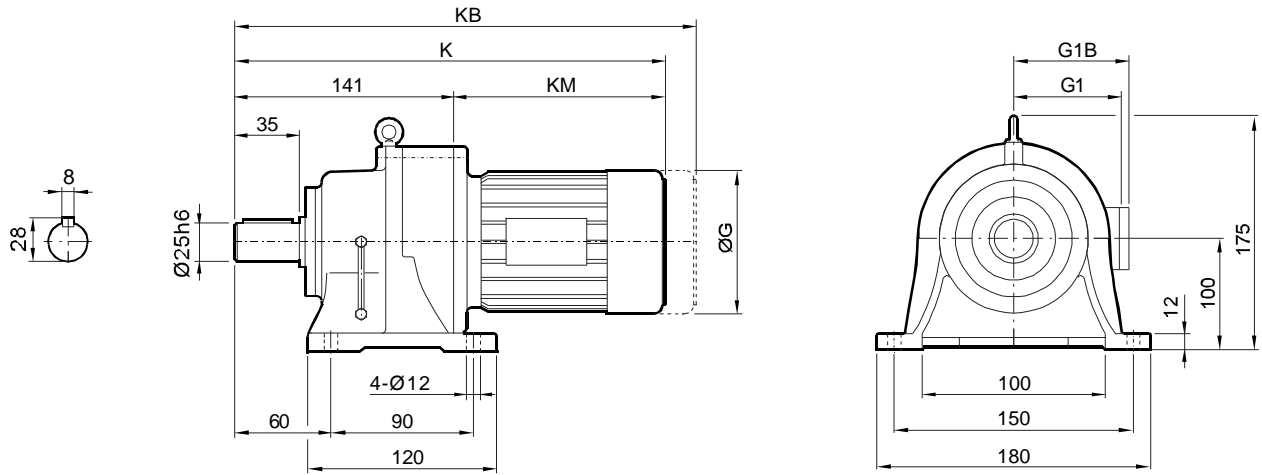

**XL1..**

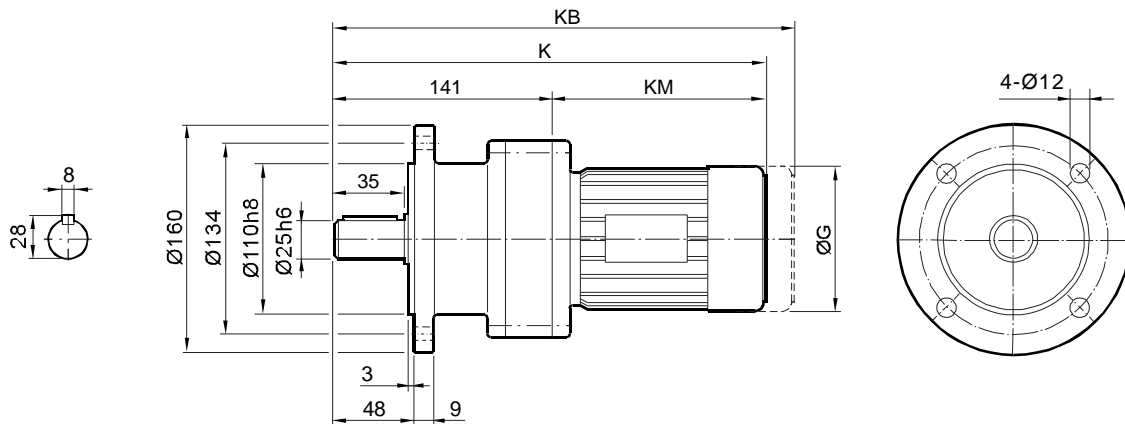

尺寸 Dimensions	电机规格 Motor frame									
	63	71	80							
<b>G</b>	132	145	175							
<b>G1</b>	99	122	145							
<b>G1B</b>	99	127	150							
<b>K</b>	290	305	355							
<b>KB</b>	366	402	432							
<b>KM</b>	149	164	214							

尺寸说明

以上尺寸为直联普通电机和制动电机尺寸；  
KB为制动电机尺寸,其余为普通电机尺寸；  
防爆电机，变频电机等须加过渡法兰，见171,172页。

**ATTENTION**

Dimensions of universal and brake motor shown in upon table,  
the others like explosion, inverter motor coupled by adaptor,  
the dimensions on page 171,172.



安装尺寸

Mounting Dimensions

**XW2..**

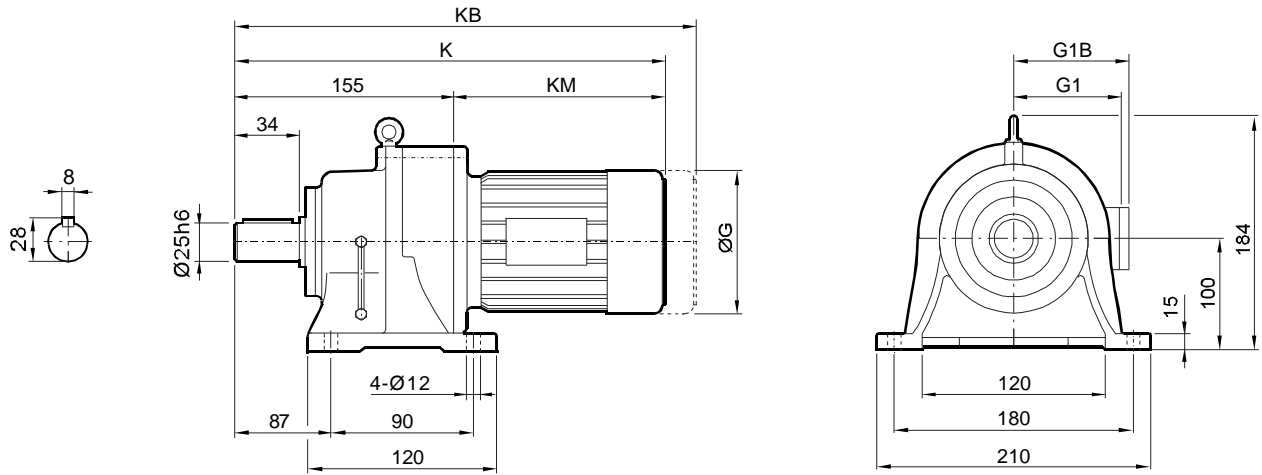

**XL2..**

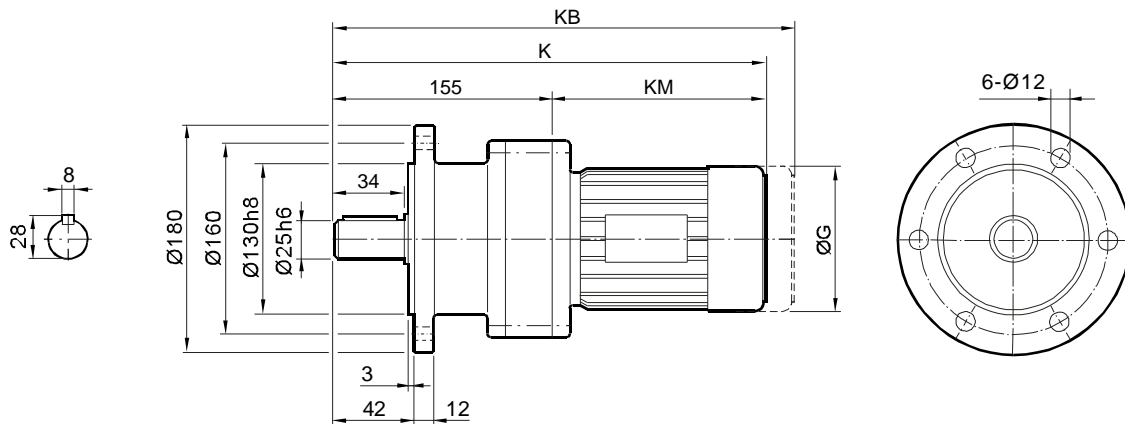

尺寸 Dimensions	电机规格 Motor frame									
	63	71	80	90						
<b>G</b>	132	145	175	197						
<b>G1</b>	99	122	145	154						
<b>G1B</b>	99	127	150	161						
<b>K</b>	346	361	411	431						
<b>KB</b>	422	458	488	555						
<b>KM</b>	191	206	256	276						

尺寸说明

以上尺寸为直联普通电机和制动电机尺寸；

KB为制动电机尺寸,其余为普通电机尺寸；

防爆电机, 变频电机等须加过渡法兰, 见171,172页。

**ATTENTION**

Dimensions of universal and brake motor shown in upon table, the others like explosion, inverter motor coupled by adaptor, the dimensions on page 171,172.



安装尺寸

Mounting Dimensions

**BW12..**

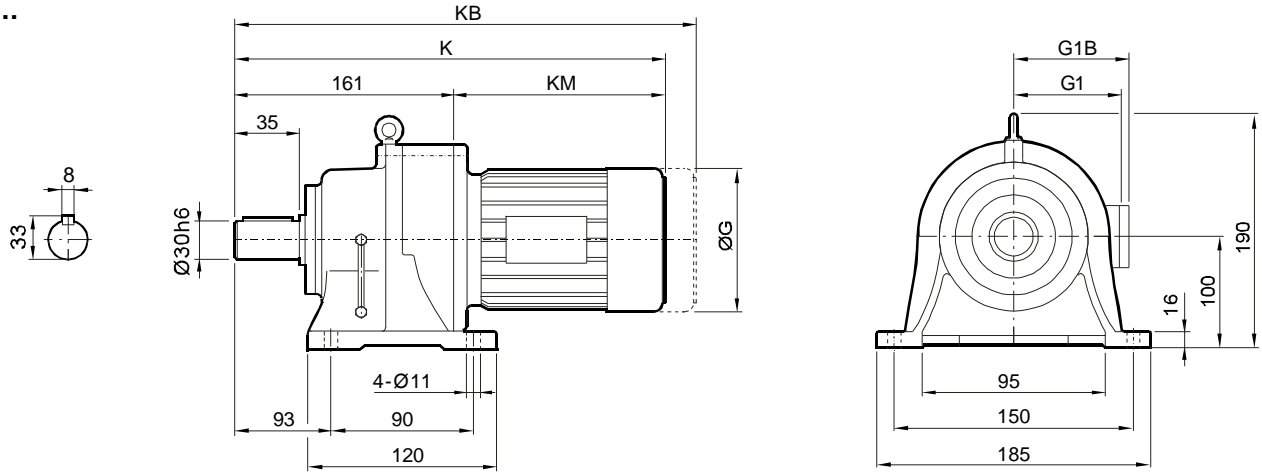

**BL12..**

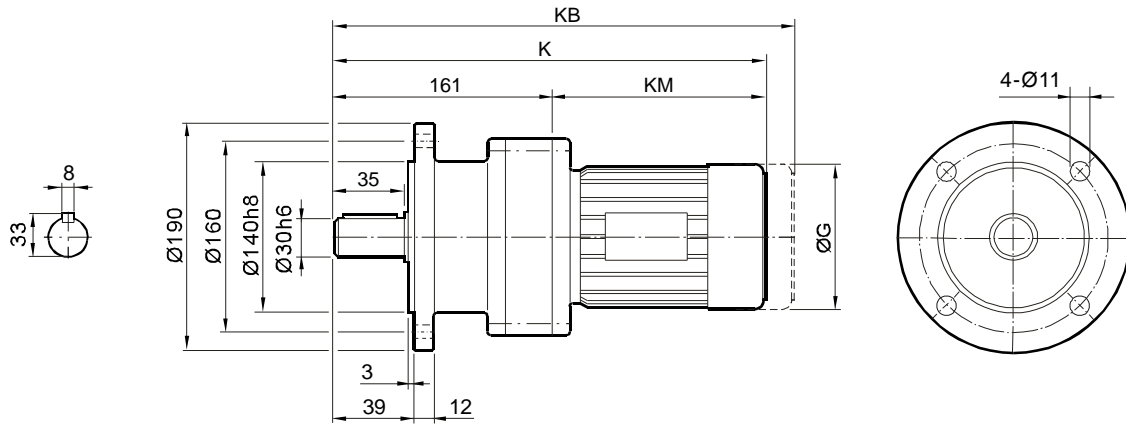

尺寸 Dimensions	电机规格 Motor frame									
	63	71	80	90						
<b>G</b>	132	145	175	197						
<b>G1</b>	99	122	145	154						
<b>G1B</b>	99	127	150	161						
<b>K</b>	384	399	449	469						
<b>KB</b>	439	463	513	554						
<b>KM</b>	191	206	256	276						

尺寸说明

以上尺寸为直联普通电机和制动电机尺寸；  
KB为制动电机尺寸,其余为普通电机尺寸；  
防爆电机，变频电机等须加过渡法兰，见171,172页。

**ATTENTION**

Dimensions of universal and brake motor shown in upon table,  
the others like explosion, inverter motor coupled by adaptor,  
the dimensions on page 171,172.



安装尺寸

Mounting Dimensions

**XW3..**

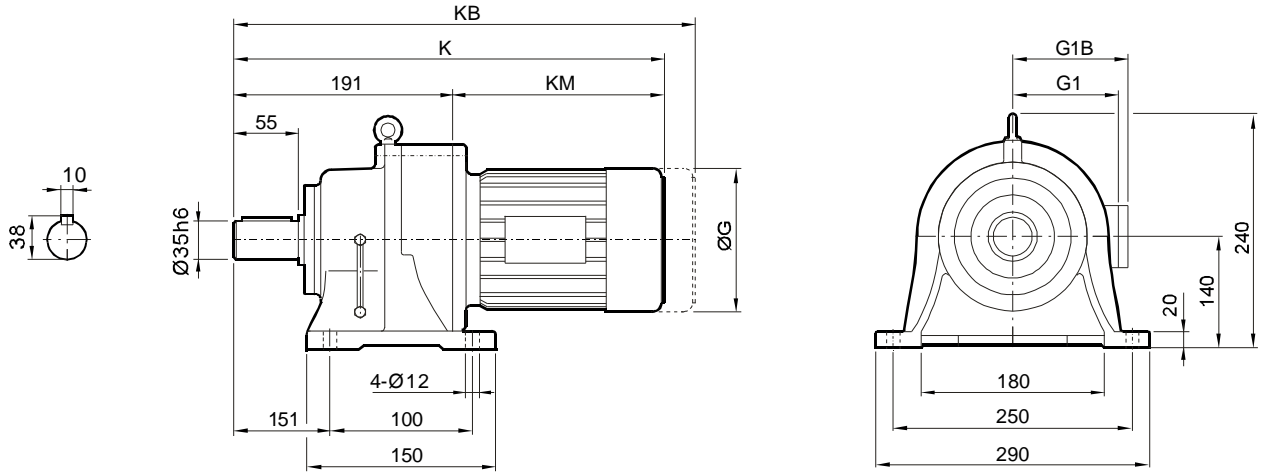

**XL3..**

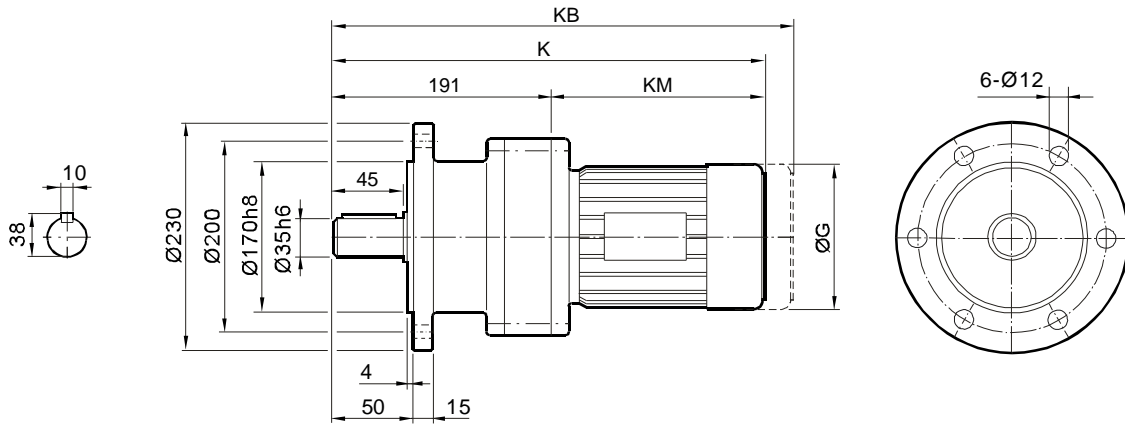

尺寸 Dimensions	电机规格 Motor frame									
	80	90	100							
<b>G</b>	175	197	197							
<b>G1</b>	145	154	166							
<b>G1B</b>	150	161	166							
<b>K</b>	440	460	510							
<b>KB</b>	515	539	607							
<b>KM</b>	249	269	319							

尺寸说明

以上尺寸为直联普通电机和制动电机尺寸；  
KB为制动电机尺寸,其余为普通电机尺寸；  
防爆电机，变频电机等须加过渡法兰，见171,172页。

**ATTENTION**

Dimensions of universal and brake motor shown in upon table,  
the others like explosion, inverter motor coupled by adaptor,  
the dimensions on page 171,172.



安装尺寸

Mounting Dimensions

**BW15..**

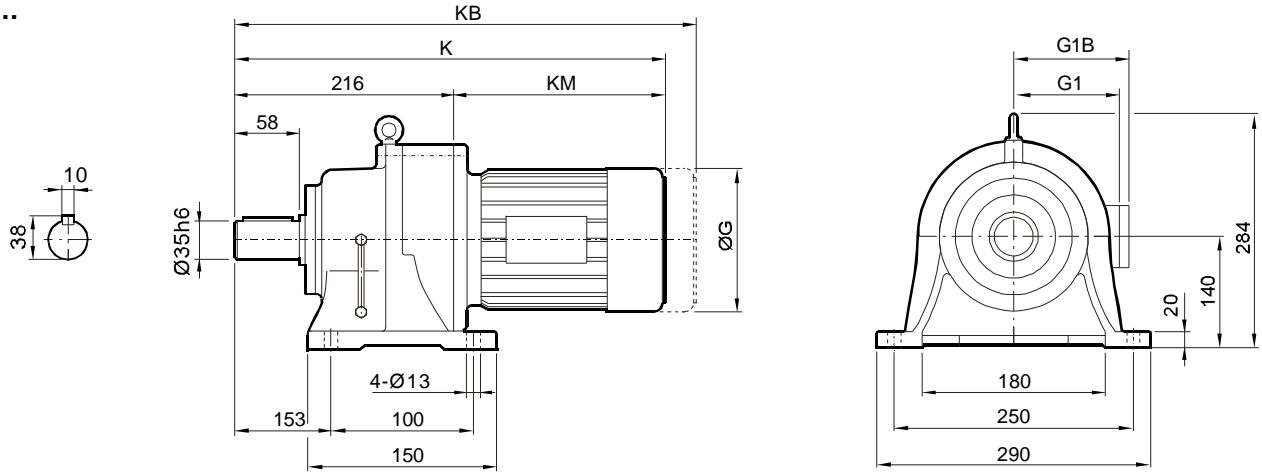

**BL15..**

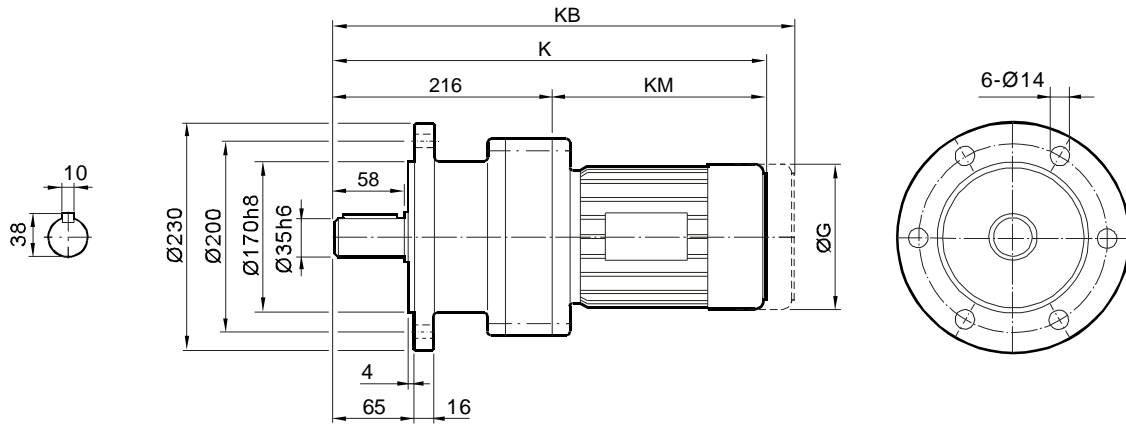

尺寸 Dimensions	电机规格 Motor frame									
	80	90	100							
<b>G</b>	175	197	197							
<b>G1</b>	145	154	166							
<b>G1B</b>	150	161	166							
<b>K</b>	465	485	535							
<b>KB</b>	540	564	632							
<b>KM</b>	249	269	319							

尺寸说明

以上尺寸为直联普通电机和制动电机尺寸；  
KB为制动电机尺寸,其余为普通电机尺寸；  
防爆电机，变频电机等须加过渡法兰，见171,172页。

**ATTENTION**

Dimensions of universal and brake motor shown in upon table,  
the others like explosion, inverter motor coupled by adaptor,  
the dimensions on page 171,172.



安装尺寸

Mounting Dimensions

**XW4.**

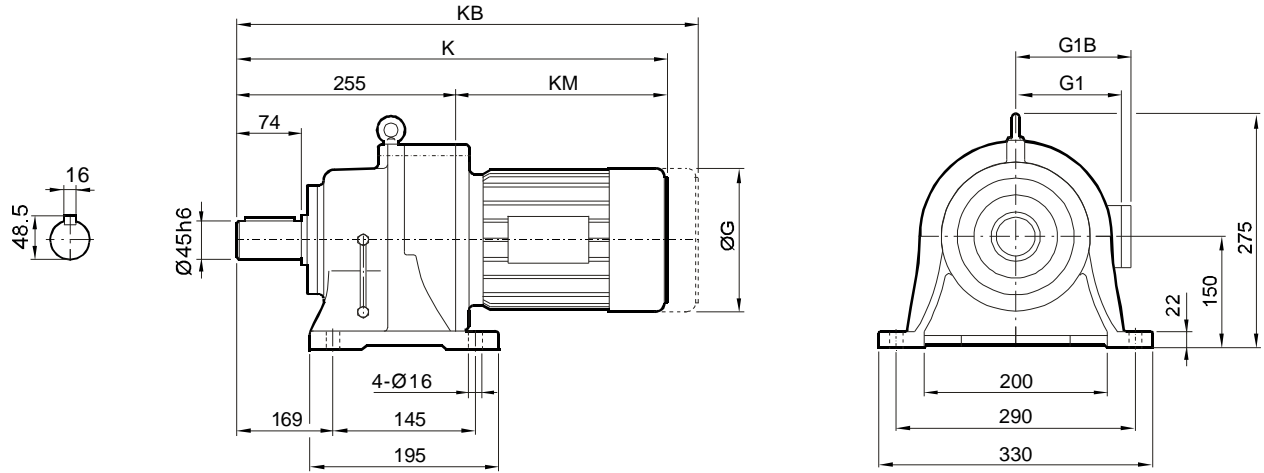

**XL4..**

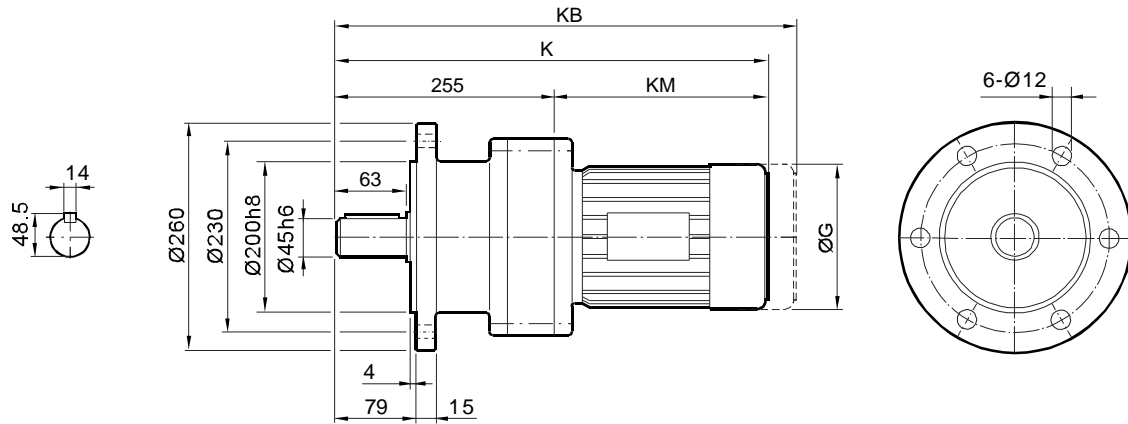

尺寸 Dimensions	电机规格 Motor frame									
	80	90	100	112						
<b>G</b>	175	197	215	240						
<b>G1</b>	145	154	175	185						
<b>G1B</b>	150	161	180	190						
<b>K</b>	504	524	574	609						
<b>KB</b>	623	668	671	709						
<b>KM</b>	249	269	319	354						

尺寸说明

以上尺寸为直联普通电机和制动电机尺寸；  
KB为制动电机尺寸,其余为普通电机尺寸；  
防爆电机，变频电机等须加过渡法兰，见171,172页。

**ATTENTION**

Dimensions of universal and brake motor shown in upon table,  
the others like explosion, inverter motor coupled by adaptor,  
the dimensions on page 171,172.



安装尺寸

Mounting Dimensions

**BW18..**

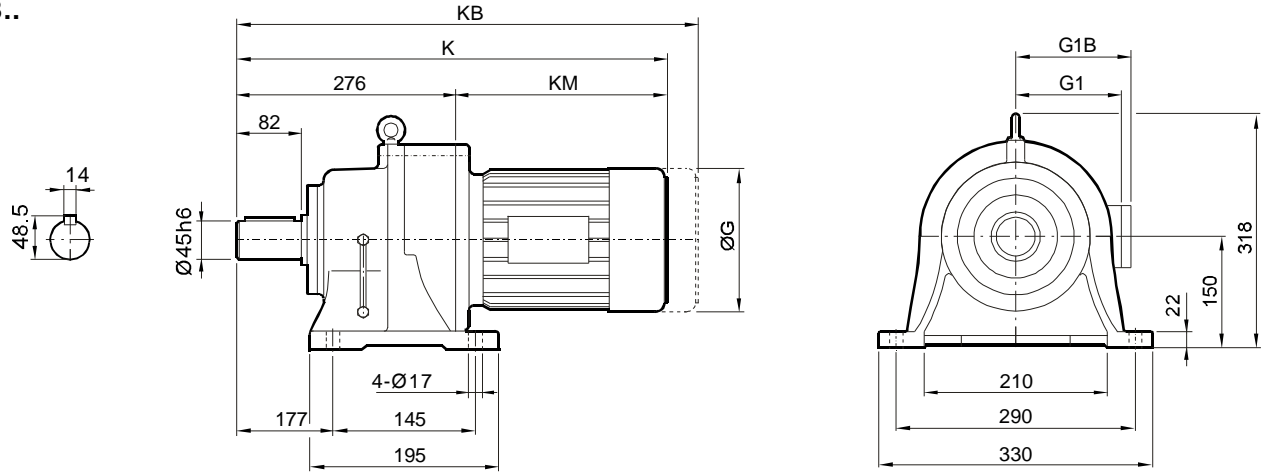

**BL18..**

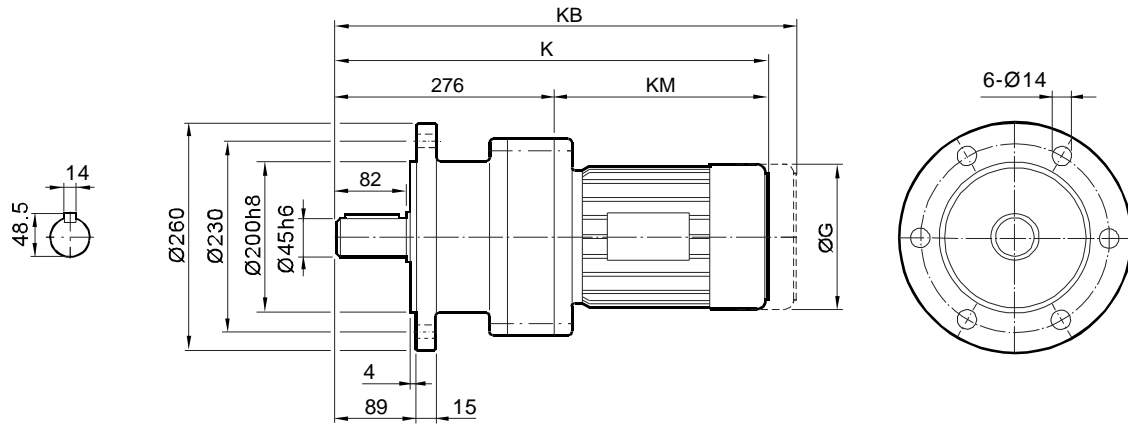

尺寸 Dimensions	电机规格				Motor frame					
	80	90	100	112						
<b>G</b>	175	197	215	240						
<b>G1</b>	145	154	175	185						
<b>G1B</b>	150	161	180	190						
<b>K</b>	525	545	595	630						
<b>KB</b>	600	624	692	730						
<b>KM</b>	249	269	319	354						

尺寸说明

以上尺寸为直联普通电机和制动电机尺寸；  
KB为制动电机尺寸,其余为普通电机尺寸；  
防爆电机，变频电机等须加过渡法兰，见171,172页。

**ATTENTION**

Dimensions of universal and brake motor shown in upon table,  
the others like explosion, inverter motor coupled by adaptor,  
the dimensions on page 171,172.



安装尺寸

Mounting Dimensions

**XW5..**

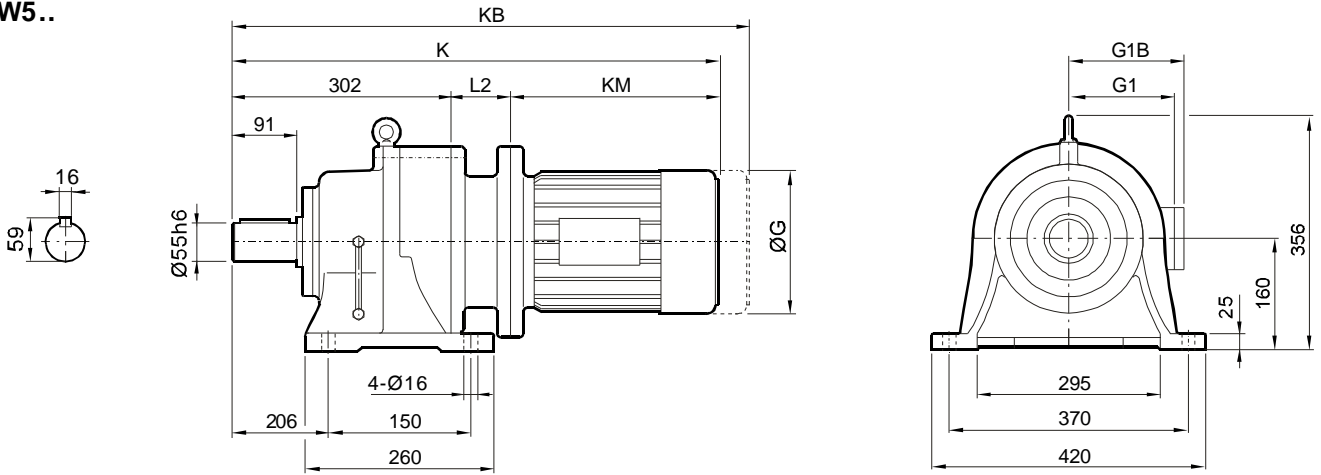

**XL5..**

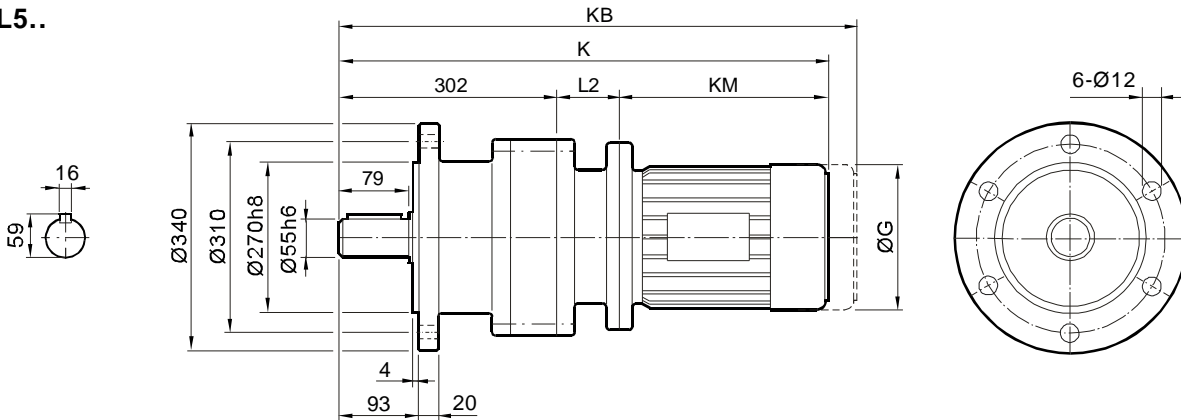

尺寸 Dimensions	电机规格 Motor frame										
	90	100	112	132S	132M	160M					
<b>G</b>	197	215	240	275	275	330					
<b>G1</b>	154	175	185	205	205	255					
<b>G1B</b>	161	180	190	230	230	280					
<b>K</b>	661	760	764	854	854	944					
<b>KB</b>	740	857	864	972	972	1098					
<b>KM</b>	261	341	345	412	412	472					
<b>L2</b>	101	117	117	140	140	170					

尺寸说明

以上尺寸为直联普通电机和制动电机尺寸；  
KB为制动电机尺寸,其余为普通电机尺寸；  
防爆电机，变频电机等须加过渡法兰，见171,172页。

**ATTENTION**

Dimensions of univeral and brake motor shown in upon table,  
the others like explosion, inverter motor coupled by adaptor,  
the dimensions on page 171,172.



安装尺寸

Mounting Dimensions

**BW22..**

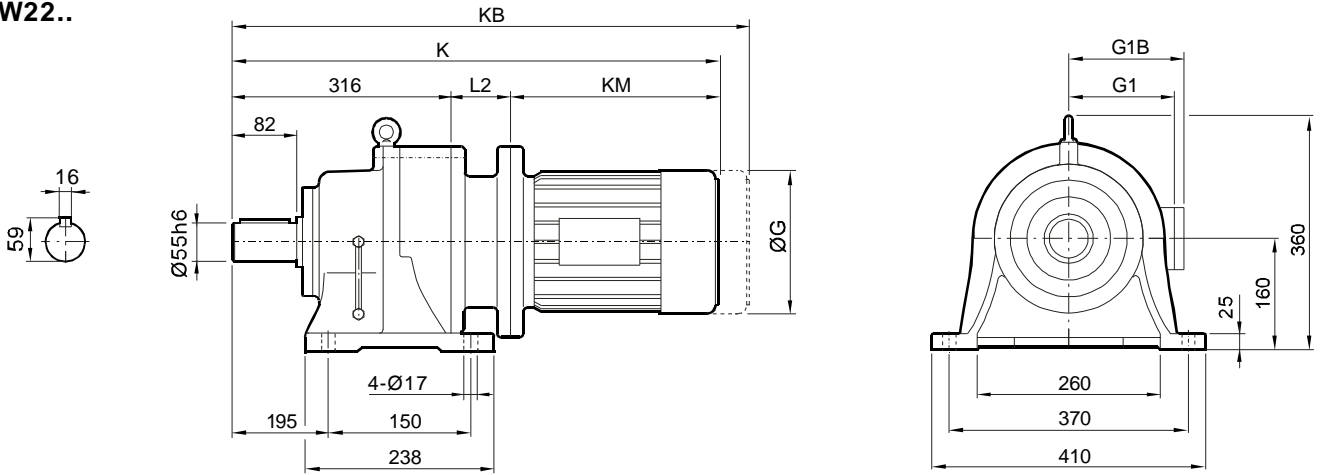

**BL22..**

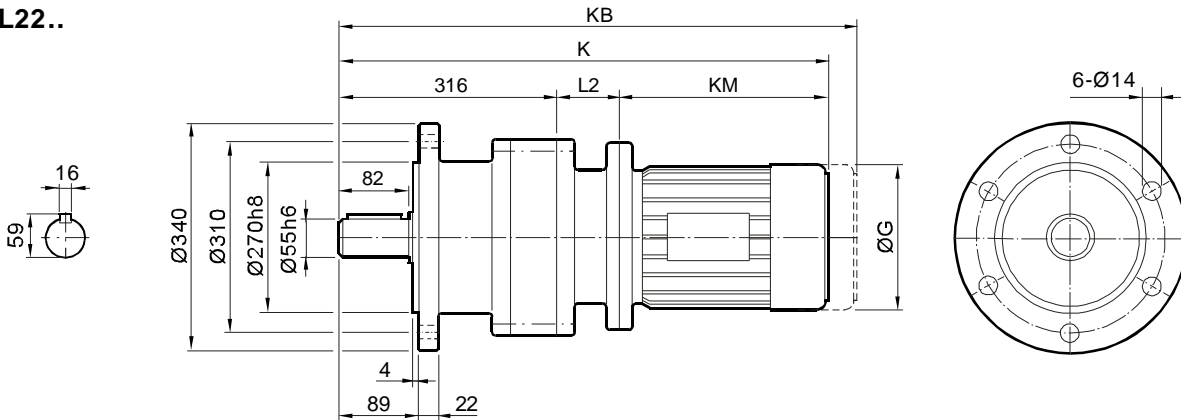

尺寸 Dimensions	电机规格 Motor frame										
	90	100	112	132S	132M	160M					
<b>G</b>	197	215	240	275	275	330					
<b>G1</b>	154	175	185	205	205	255					
<b>G1B</b>	161	180	190	230	230	280					
<b>K</b>	675	774	778	868	868	958					
<b>KB</b>	754	871	878	986	986	1112					
<b>KM</b>	261	341	345	412	412	472					
<b>L2</b>	101	117	117	140	140	170					

尺寸说明

以上尺寸为直联普通电机和制动电机尺寸；  
KB为制动电机尺寸,其余为普通电机尺寸；  
防爆电机，变频电机等须加过渡法兰，见171,172页。

**ATTENTION**

Dimensions of universal and brake motor shown in upon table,  
the others like explosion, inverter motor coupled by adaptor,  
the dimensions on page 171,172.



安装尺寸

Mounting Dimensions

**XW6..**

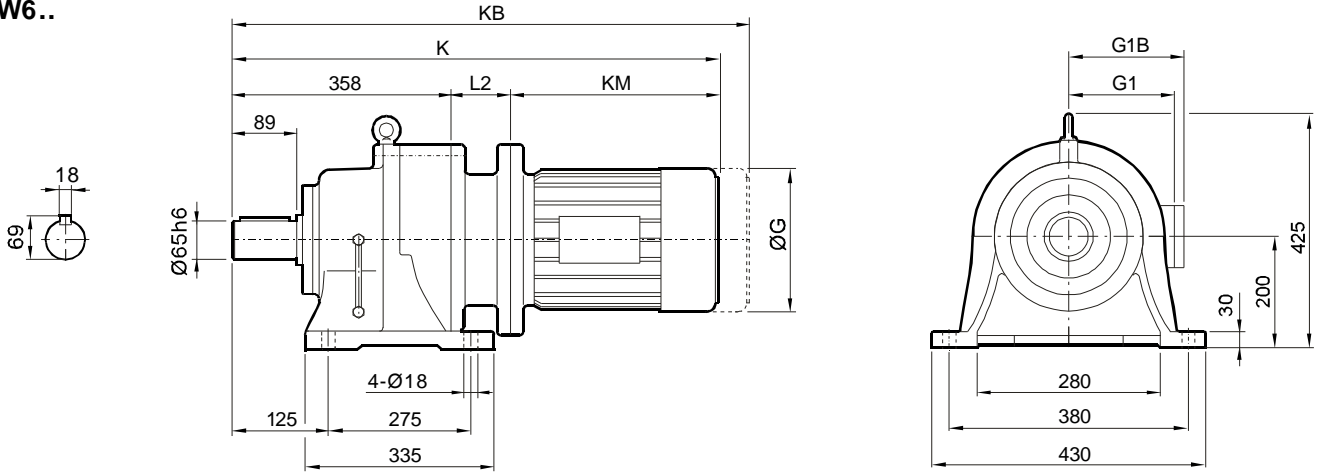

**XL6..**

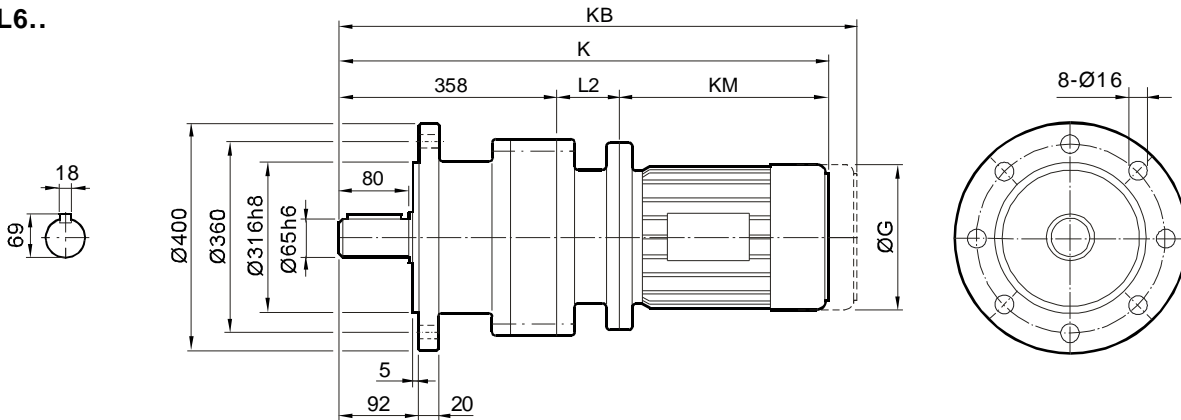

尺寸 Dimensions	电机规格 Motor frame											
	100	112	132S	132M	160M	160L						
<b>G</b>	215	240	275	275	330	330						
<b>G1</b>	175	185	205	205	255	255						
<b>G1B</b>	180	190	230	230	280	280						
<b>K</b>	812	816	912	912	1009	1064						
<b>KB</b>	909	916	1030	1030	1163	1218						
<b>KM</b>	341	345	412	412	472	527						
<b>L2</b>	113	113	142	142	179	179						

尺寸说明

以上尺寸为直联普通电机和制动电机尺寸；  
KB为制动电机尺寸,其余为普通电机尺寸；  
防爆电机，变频电机等须加过渡法兰，见171,172页。

**ATTENTION**

Dimensions of universal and brake motor shown in upon table,  
the others like explosion, inverter motor coupled by adaptor,  
the dimensions on page 171,172.



安装尺寸

Mounting Dimensions

**BW27..**

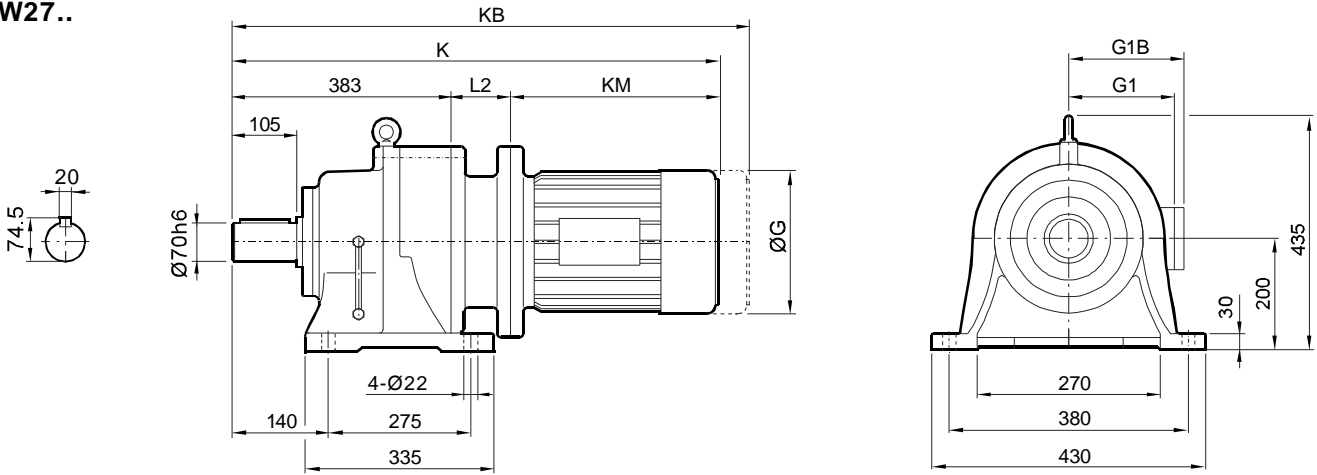

**BL27..**

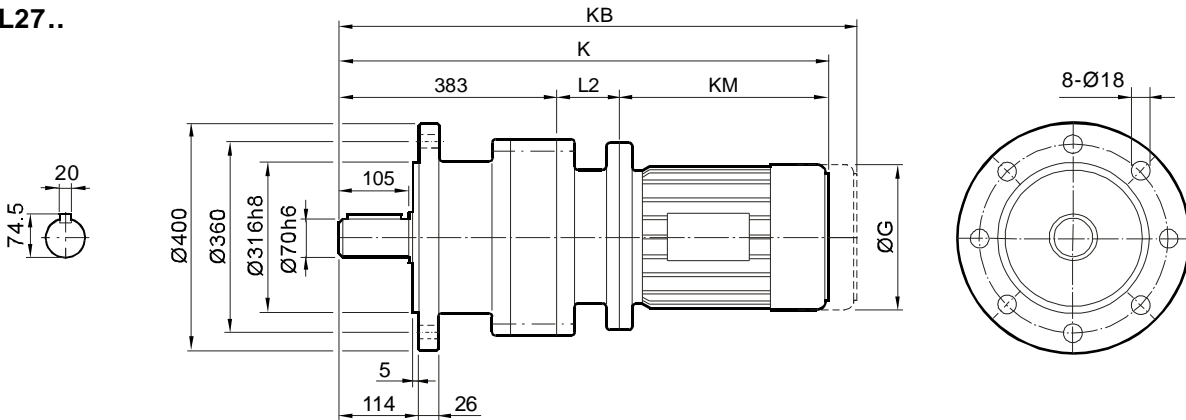

尺寸 Dimensions	电机规格 Motor frame									
	100	112	132S	132M	160M	160L				
<b>G</b>	215	240	275	275	330	330				
<b>G1</b>	175	185	205	205	255	255				
<b>G1B</b>	180	190	230	230	280	280				
<b>K</b>	837	841	937	937	1034	1089				
<b>KB</b>	934	941	1055	1055	1188	1243				
<b>KM</b>	341	345	412	412	472	527				
<b>L2</b>	113	113	142	142	179	179				

尺寸说明

以上尺寸为直联普通电机和制动电机尺寸；  
KB为制动电机尺寸,其余为普通电机尺寸；  
防爆电机，变频电机等须加过渡法兰，见171,172页。

**ATTENTION**

Dimensions of univeral and brake motor shown in upon table,  
the others like explosion, inverter motor coupled by adaptor,  
the dimensions on page 171,172.



安装尺寸

Mounting Dimensions

**XW7..**

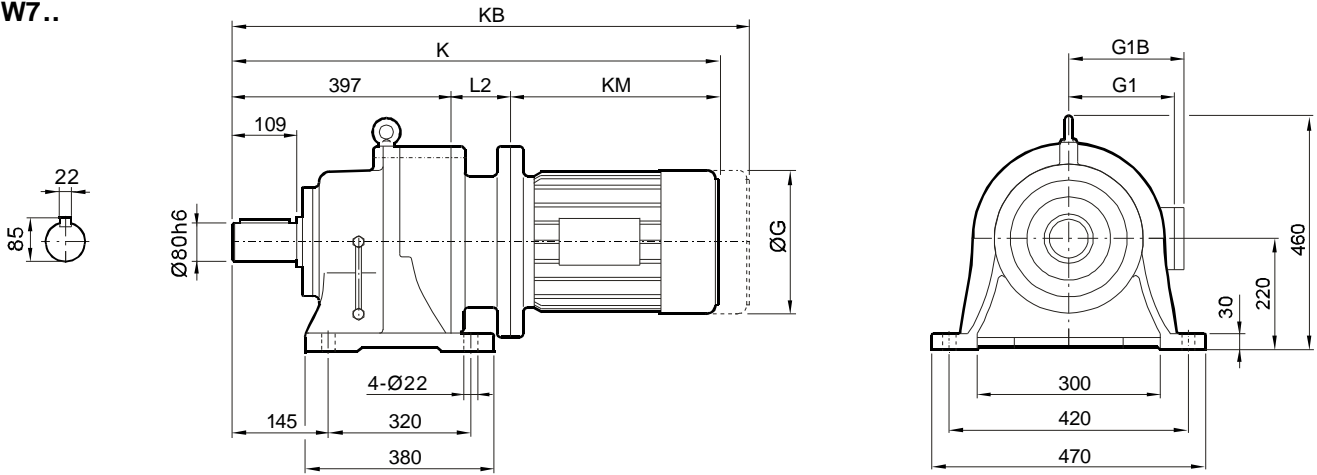

**XL7..**

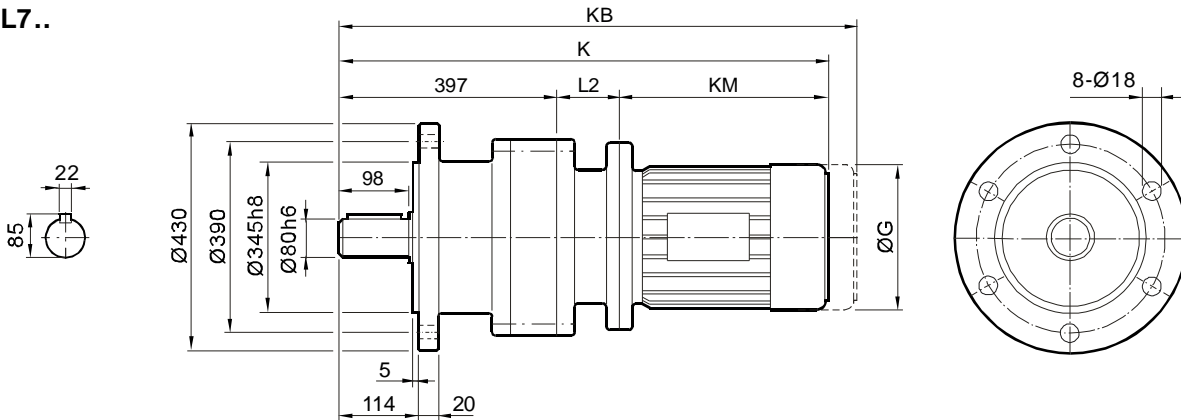

尺寸 Dimensions	电机规格 Motor frame											
	100	112	132S	132M	160M	160L						
<b>G</b>	215	240	275	275	330	330						
<b>G1</b>	175	185	205	205	255	255						
<b>G1B</b>	180	190	230	230	280	280						
<b>K</b>	851	855	951	951	1048	1103						
<b>KB</b>	948	955	1069	1069	1202	1257						
<b>KM</b>	341	345	412	412	472	527						
<b>L2</b>	113	113	142	142	179	179						

尺寸说明

以上尺寸为直联普通电机和制动电机尺寸；  
KB为制动电机尺寸,其余为普通电机尺寸；  
防爆电机，变频电机等须加过渡法兰，见171,172页。

**ATTENTION**

Dimensions of universal and brake motor shown in upon table,  
the others like explosion, inverter motor coupled by adaptor,  
the dimensions on page 171,172.



安装尺寸

Mounting Dimensions

**XW8..**

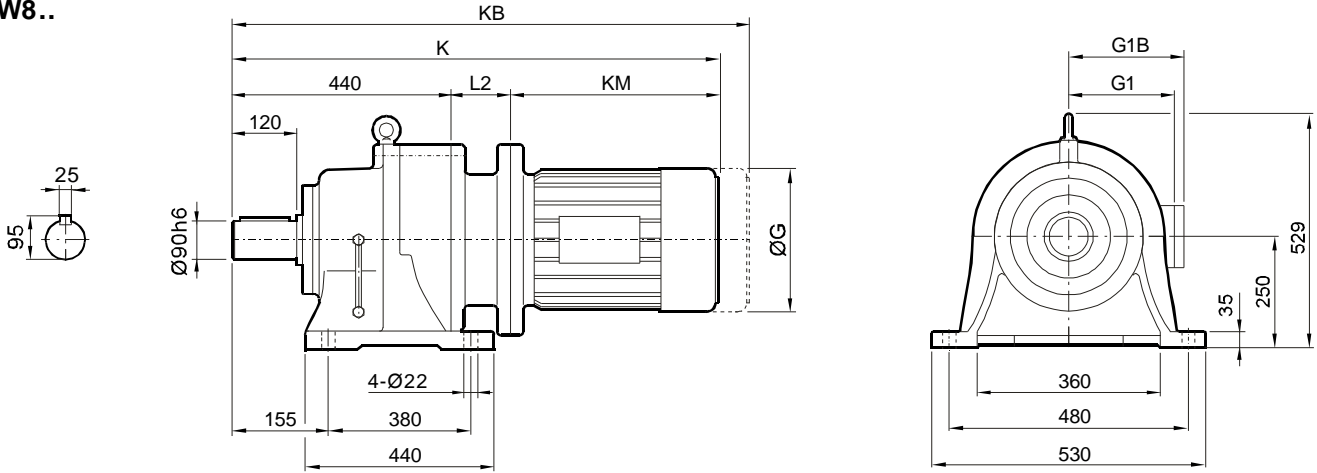

**XL8..**

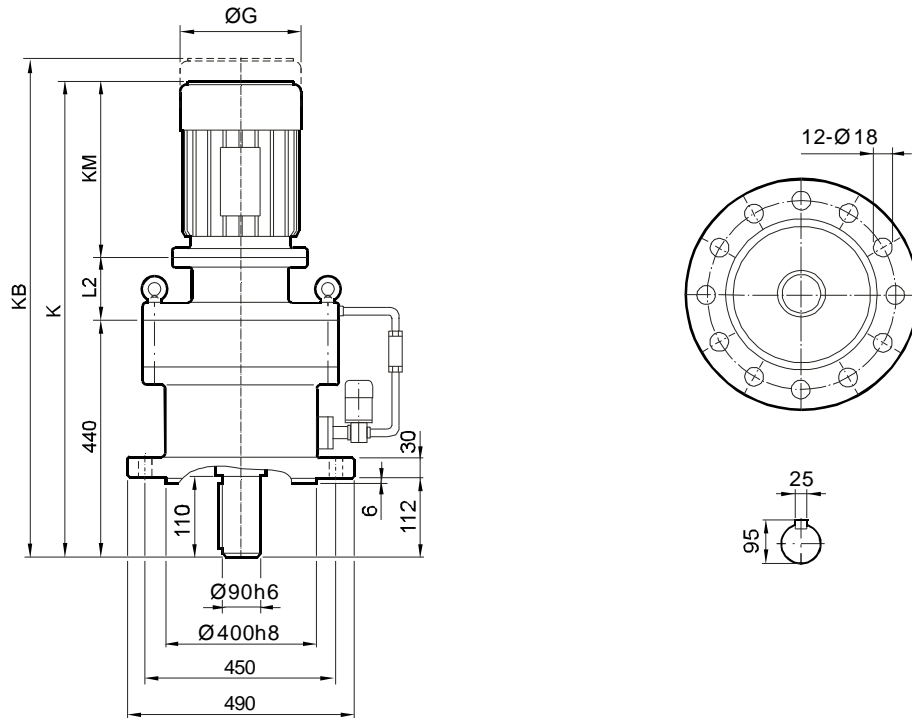

尺寸 Dimensions	电机规格 Motor frame								
	112	132S	132M	160M	160L	180L	200		
<b>G</b>	240	275	275	330	330	330	420		
<b>G1</b>	185	205	205	255	255	255	305		
<b>G1B</b>	190	230	230	280	280	280	330		
<b>K</b>	898	994	994	1148	1160	1200	1209		
<b>KB</b>	998	1112	1112	1302	1314	1354	1363		
<b>KM</b>	345	412	412	472	527	567	587		
<b>L2</b>	113	142	142	193	193	193	182		

尺寸说明

以上尺寸为直联普通电机和制动电机尺寸；  
KB为制动电机尺寸,其余为普通电机尺寸；  
防爆电机，变频电机等须加过渡法兰，见171,172页。

**ATTENTION**

Dimensions of universal and brake motor shown in upon table,  
the others like explosion, inverter motor coupled by adaptor,  
the dimensions on page 171,172.



安装尺寸

Mounting Dimensions

**BW33..**

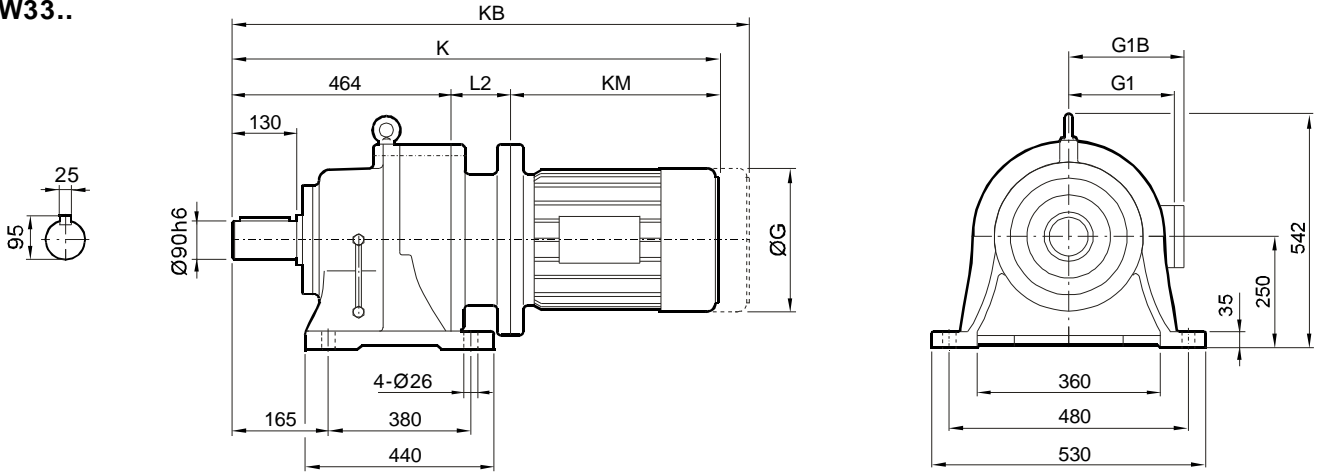

**BL33..**

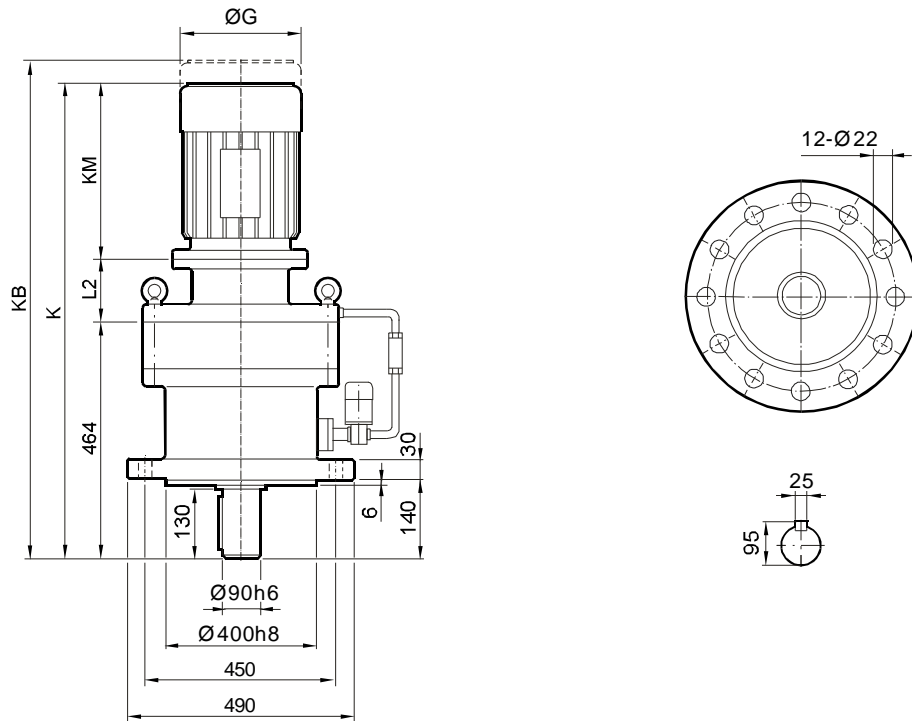

尺寸 Dimensions	电机规格 Motor frame								
	112	132S	132M	160M	160L	180L	200		
<b>G</b>	240	275	275	330	330	330	420		
<b>G1</b>	185	205	205	255	255	255	305		
<b>G1B</b>	190	230	230	280	280	280	330		
<b>K</b>	922	1018	1018	1172	1184	1224	1233		
<b>KB</b>	1022	1136	1136	1326	1338	1378	1387		
<b>KM</b>	345	412	412	472	527	567	587		
<b>L2</b>	113	142	142	193	193	193	182		

尺寸说明

以上尺寸为直联普通电机和制动电机尺寸；  
KB为制动电机尺寸,其余为普通电机尺寸；  
防爆电机，变频电机等须加过渡法兰，见171,172页。

**ATTENTION**

Dimensions of univeral and brake motor shown in upon table,  
the others like explosion, inverter motor coupled by adaptor,  
the dimensions on page 171,172.



安装尺寸

Mounting Dimensions

**XW9..**

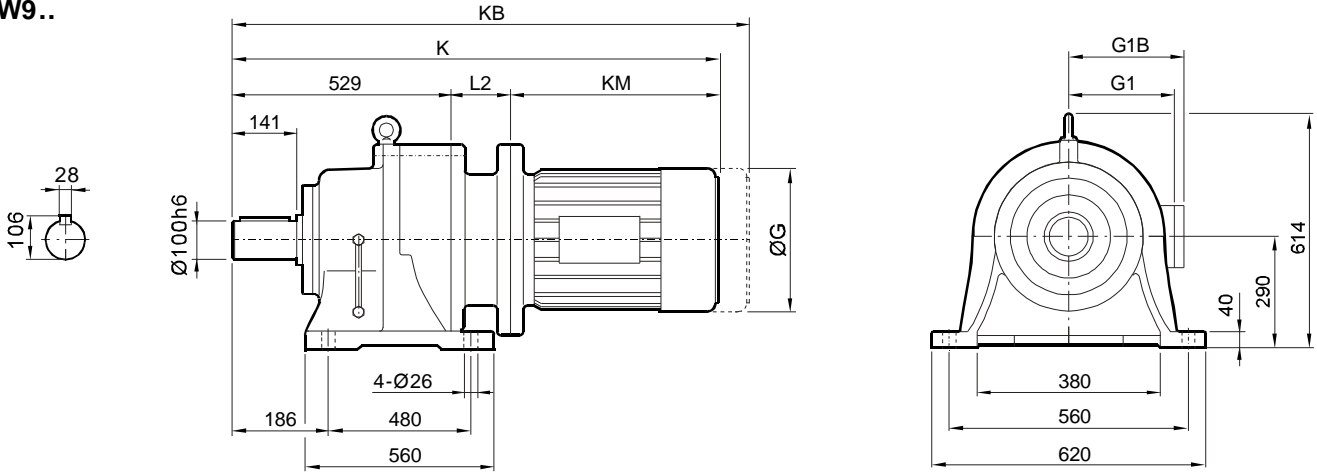

**XL9..**

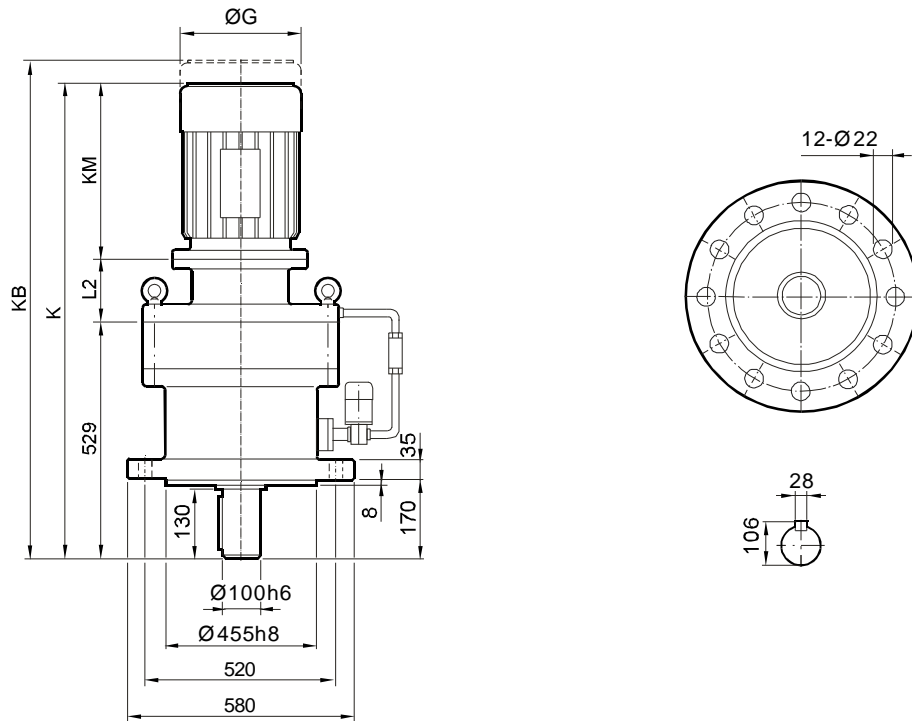

尺寸 Dimensions	电机规格 Motor frame								
	112	132S	132M	160M	160L	180L	200		
<b>G</b>	240	275	275	330	330	330	420		
<b>G1</b>	185	205	205	255	255	255	305		
<b>G1B</b>	190	230	230	280	280	280	330		
<b>K</b>	987	1083	1083	1237	1249	1289	1303		
<b>KB</b>	1087	1101	1101	1391	1403	1443	1457		
<b>KM</b>	345	412	412	472	527	567	587		
<b>L2</b>	113	142	142	193	193	193	187		

尺寸说明

以上尺寸为直联普通电机和制动电机尺寸；  
KB为制动电机尺寸,其余为普通电机尺寸；  
防爆电机，变频电机等须加过渡法兰，见171,172页。

**ATTENTION**

Dimensions of universal and brake motor shown in upon table,  
the others like explosion, inverter motor coupled by adaptor,  
the dimensions on page 171,172.



安装尺寸

Mounting Dimensions

**BW39..**

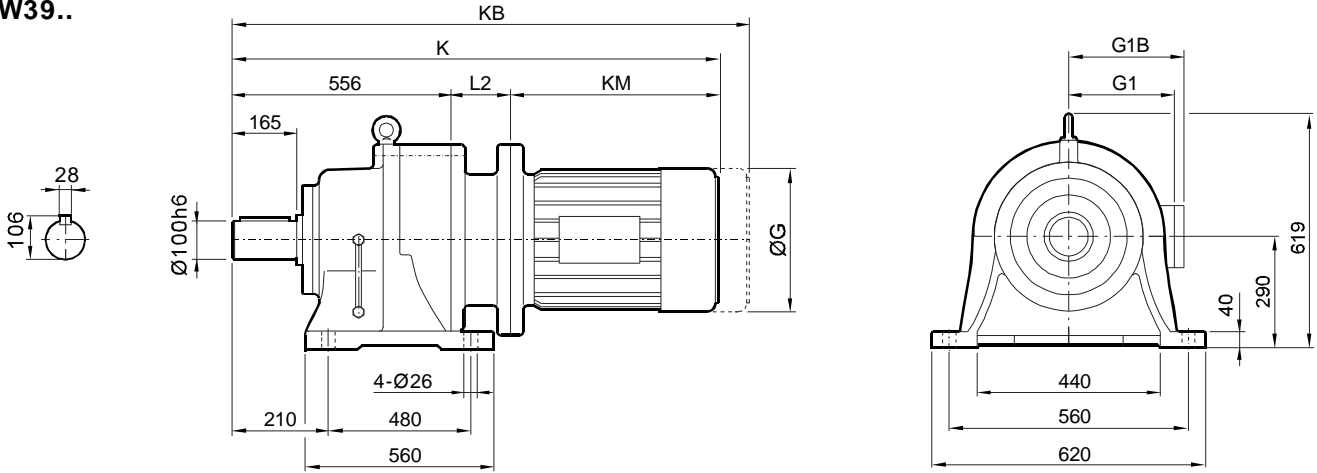

**BL39..**

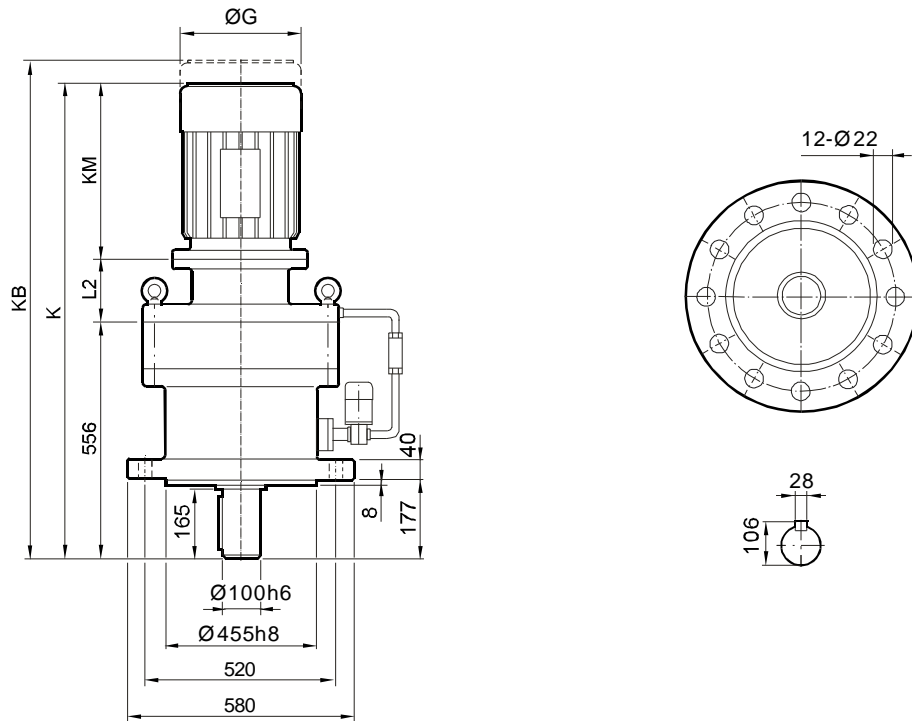

尺寸 Dimensions	电机规格 Motor frame								
	112	132S	132M	160M	160L	180L	200		
<b>G</b>	240	275	275	330	330	330	420		
<b>G1</b>	185	205	205	255	255	255	305		
<b>G1B</b>	190	230	230	280	280	280	330		
<b>K</b>	1014	1110	1110	1264	1276	1316	1330		
<b>KB</b>	1114	1128	1128	1418	1430	1470	1484		
<b>KM</b>	345	412	412	472	527	567	587		
<b>L2</b>	113	142	142	193	193	193	187		

尺寸说明

以上尺寸为直联普通电机和制动电机尺寸；  
KB为制动电机尺寸,其余为普通电机尺寸；  
防爆电机，变频电机等须加过渡法兰，见171,172页。

**ATTENTION**

Dimensions of universal and brake motor shown in upon table,  
the others like explosion, inverter motor coupled by adaptor,  
the dimensions on page 171,172.



安装尺寸

Mounting Dimensions

**XW10..**

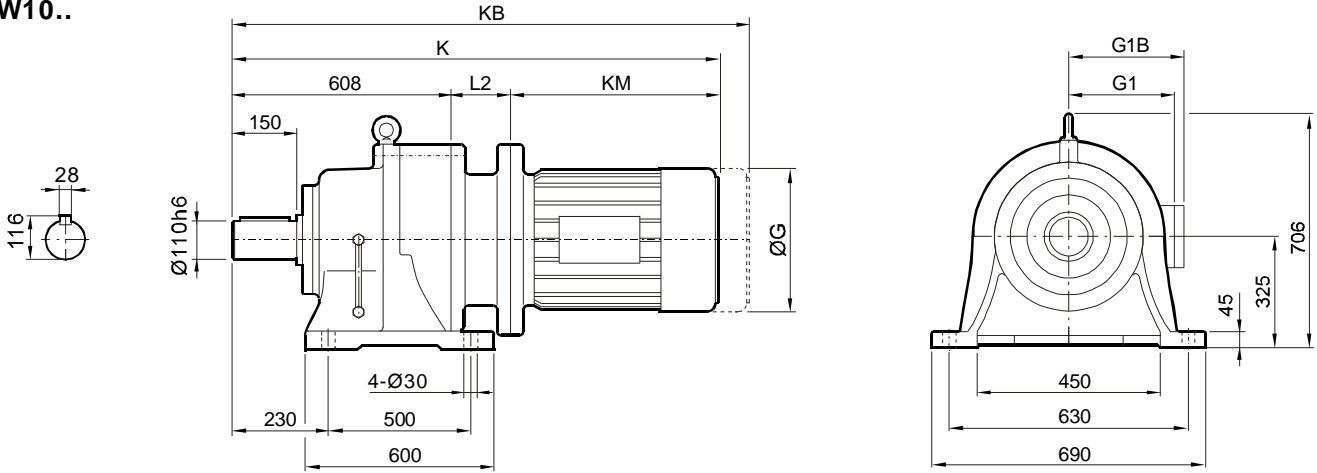

**XL10..**

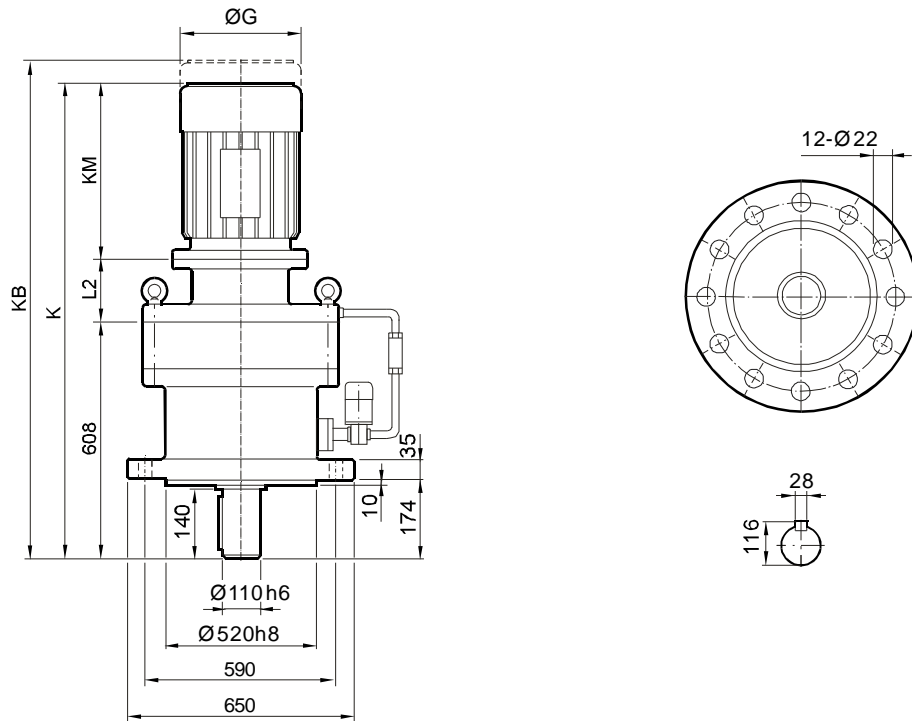

尺寸 Dimensions	电机规格 Motor frame										
	160M	160L	180L	200	225S	225M	250M	280S	280M		
<b>G</b>	330	330	330	420	470	470	510	580	580		
<b>G1</b>	255	255	255	305	325	325	305	305	305		
<b>G1B</b>	280	280	280	330	360	360	-	-	-		
<b>K</b>	1273	1285	1325	1339	1475	1505	1570	1645	1695		
<b>KB</b>	1427	1439	1479	1493	1660	1690	-	-	-		
<b>KM</b>	472	527	567	587	675	705	770	845	895		
<b>L2</b>	193	193	193	192	192	192	192	192	192		

尺寸说明

以上尺寸为直联普通电机和制动电机尺寸；  
KB为制动电机尺寸,其余为普通电机尺寸；  
防爆电机，变频电机等须加过渡法兰，见171,172页。

**ATTENTION**

Dimensions of universal and brake motor shown in upon table,  
the others like explosion, inverter motor coupled by adaptor,  
the dimensions on page 171,172.



安装尺寸

Mounting Dimensions

**BW45..**

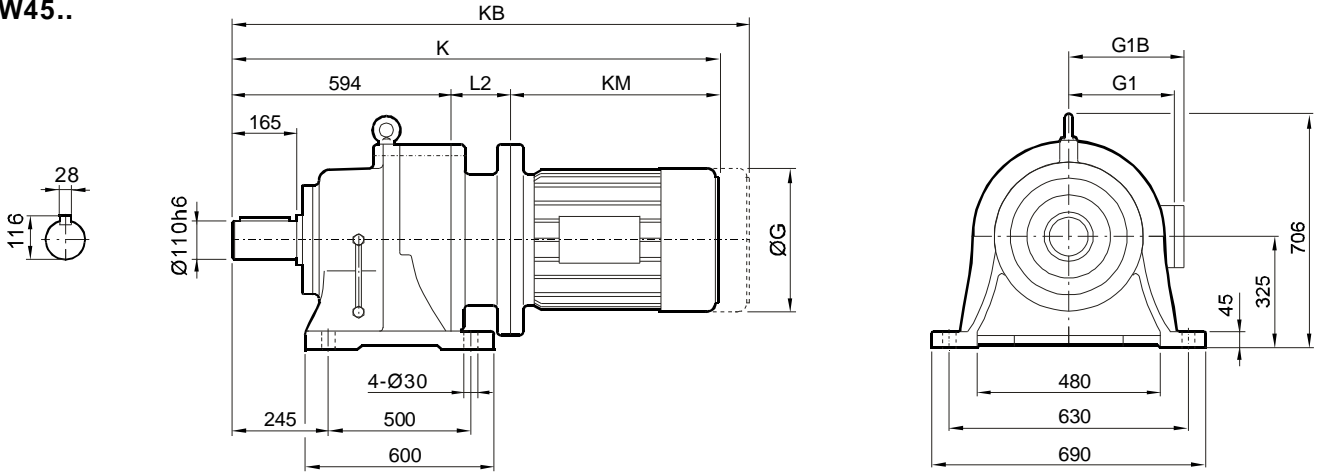

**BL45..**

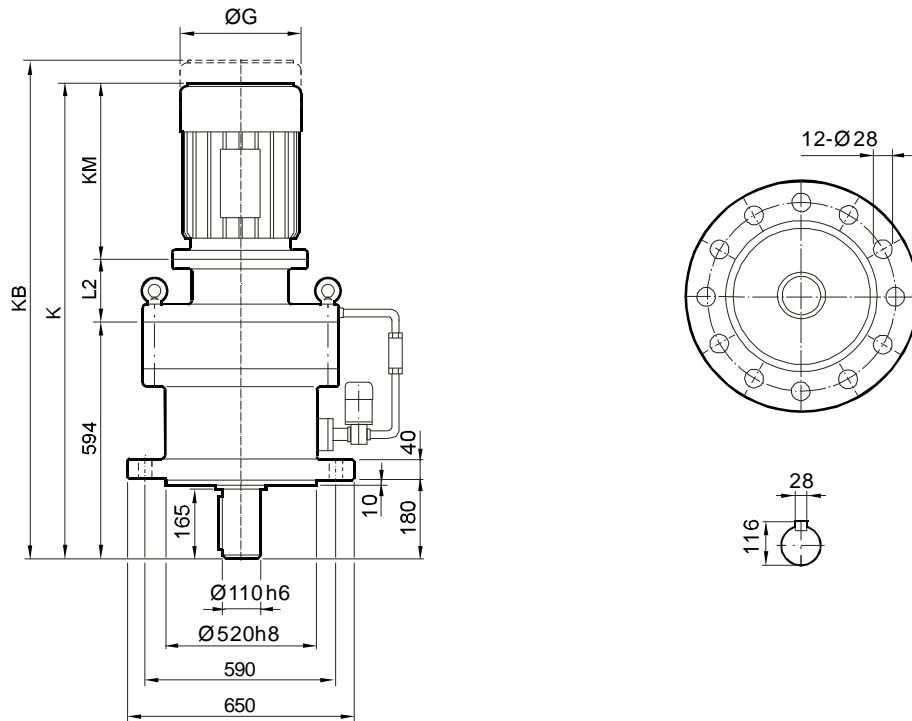

尺寸 Dimensions	电机规格 Motor frame										
	160M	160L	180L	200	225S	225M	250M	280S	280M		
<b>G</b>	330	330	330	420	470	470	510	580	580		
<b>G1</b>	255	255	255	305	325	325	305	305	305		
<b>G1B</b>	280	280	280	330	360	360	-	-	-		
<b>K</b>	1259	1271	1311	1325	1461	1491	1556	1631	1681		
<b>KB</b>	1413	1425	1465	1479	1646	1676	-	-	-		
<b>KM</b>	472	527	567	587	675	705	770	845	895		
<b>L2</b>	193	193	193	192	192	192	192	192	192		

尺寸说明

以上尺寸为直联普通电机和制动电机尺寸；  
KB为制动电机尺寸,其余为普通电机尺寸；  
防爆电机，变频电机等须加过渡法兰，见171,172页。

**ATTENTION**

Dimensions of universal and brake motor shown in upon table,  
the others like explosion, inverter motor coupled by adaptor,  
the dimensions on page 171,172.



安装尺寸

Mounting Dimensions

XW11..

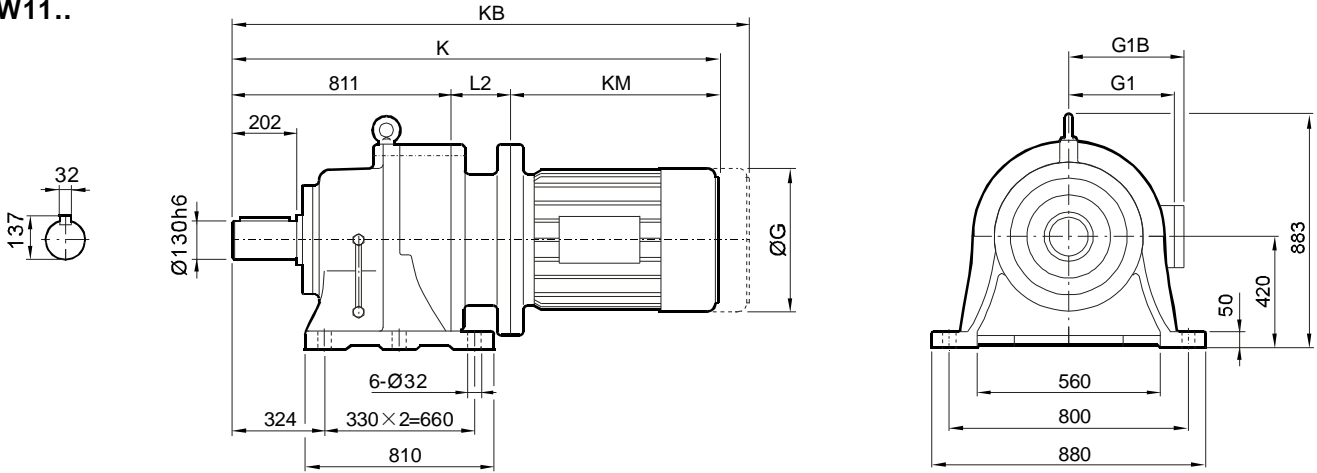

XL11..

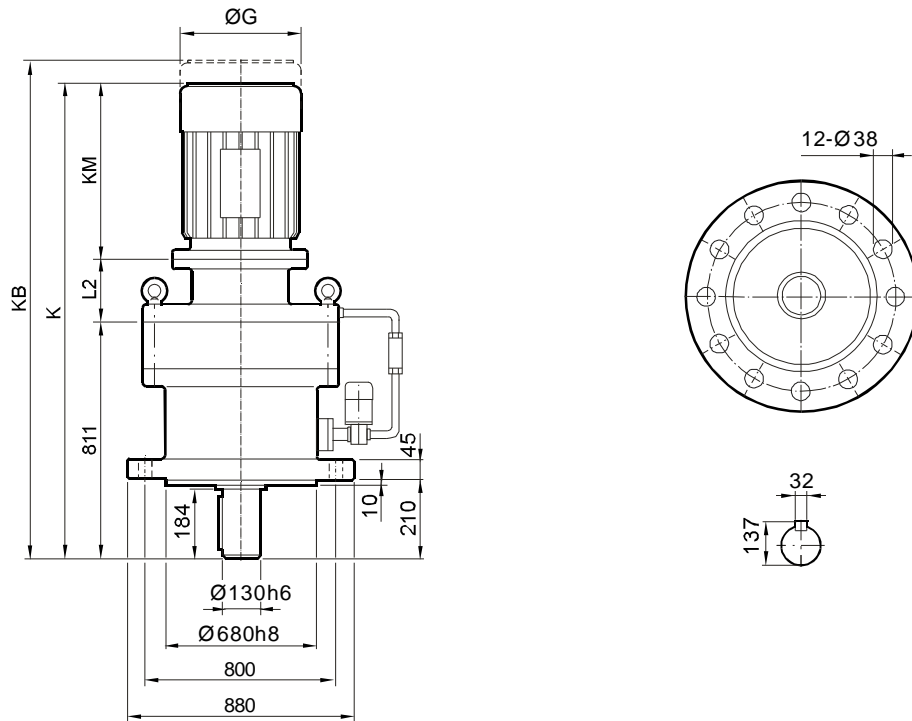

尺寸 Dimensions	电机规格 Motor frame										
	160M	160L	180L	200	225S	225M	250M	280S	280M		
<b>G</b>	330	330	330	420	470	470	510	580	580		
<b>G1</b>	255	255	255	305	325	325	305	305	305		
<b>G1B</b>	280	280	280	330	360	360	-	-	-		
<b>K</b>	1398	1410	1450	1464	1600	1630	1695	1770	1820		
<b>KB</b>	1552	1564	1604	1618	1785	1815	-	-	-		
<b>KM</b>	472	527	567	587	675	705	770	845	895		
<b>L2</b>	193	193	193	192	192	192	192	192	192		

尺寸说明

以上尺寸为直联普通电机和制动电机尺寸；  
KB为制动电机尺寸,其余为普通电机尺寸；  
防爆电机，变频电机等须加过渡法兰，见171,172页。

ATTENTION

Dimensions of universal and brake motor shown in upon table,  
the others like explosion, inverter motor coupled by adaptor,  
the dimensions on page 171,172.



安装尺寸

Mounting Dimensions

**BW55..**

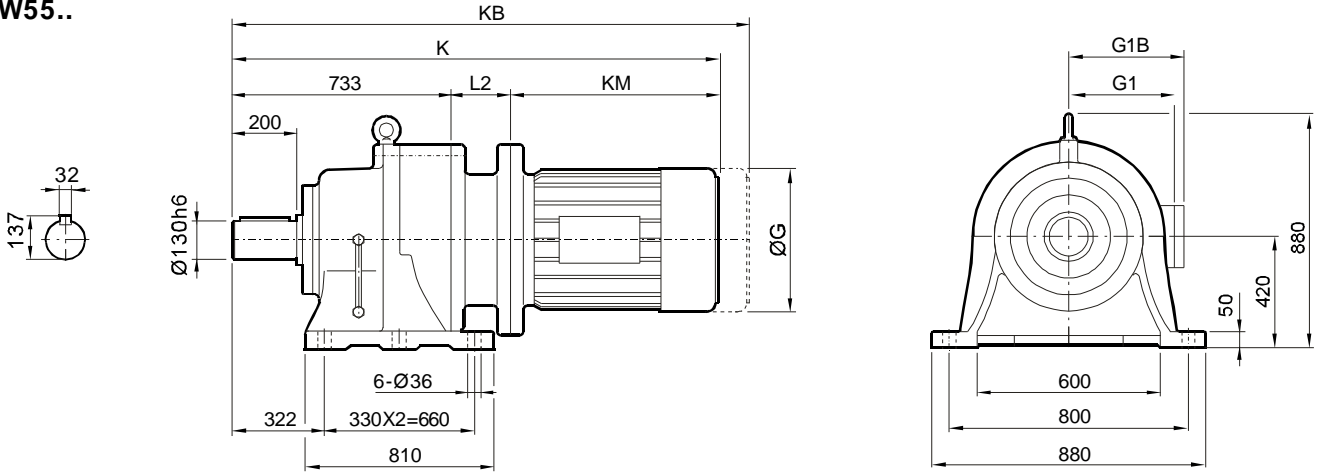

**BL55..**

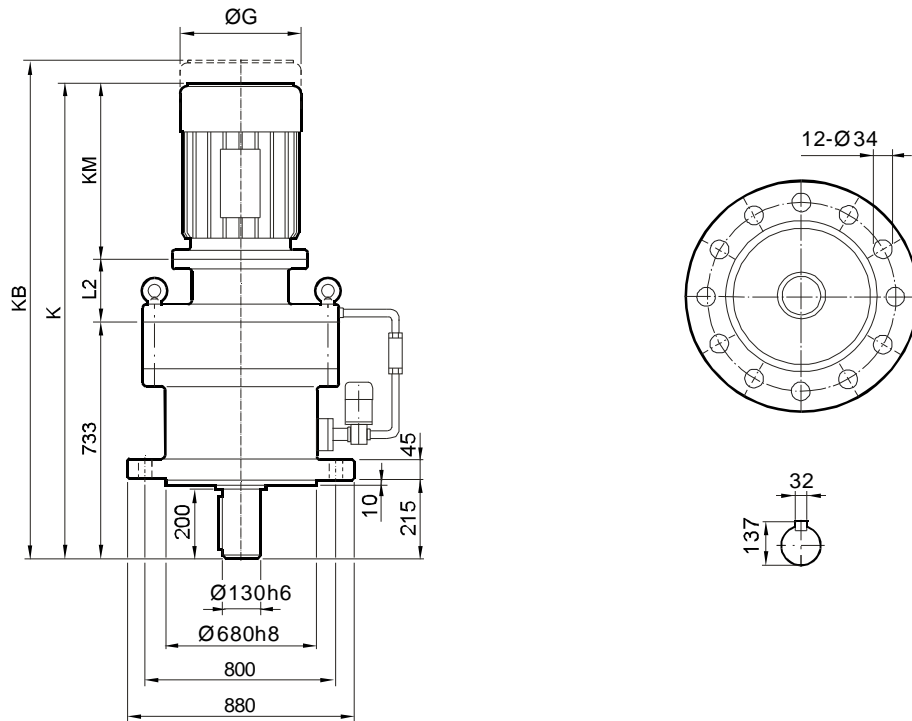

尺寸 Dimensions	电机规格 Motor frame										
	160M	160L	180L	200	225S	225M	250M	280S	280M		
<b>G</b>	330	330	330	420	470	470	510	580	580		
<b>G1</b>	255	255	255	305	325	325	305	305	305		
<b>G1B</b>	280	280	280	330	360	360	-	-	-		
<b>K</b>	1476	1488	1528	1542	1678	1708	1773	1848	1898		
<b>KB</b>	1630	1642	1682	1696	1863	1893	-	-	-		
<b>KM</b>	472	527	567	587	675	705	770	845	895		
<b>L2</b>	193	193	193	192	192	192	192	192	192		

尺寸说明

以上尺寸为直联普通电机和制动电机尺寸；  
KB为制动电机尺寸,其余为普通电机尺寸；  
防爆电机，变频电机等须加过渡法兰，见171,172页。

**ATTENTION**

Dimensions of universal and brake motor shown in upon table,  
the others like explosion, inverter motor coupled by adaptor,  
the dimensions on page 171,172.



安装尺寸

Mounting Dimensions

**XWE31..**

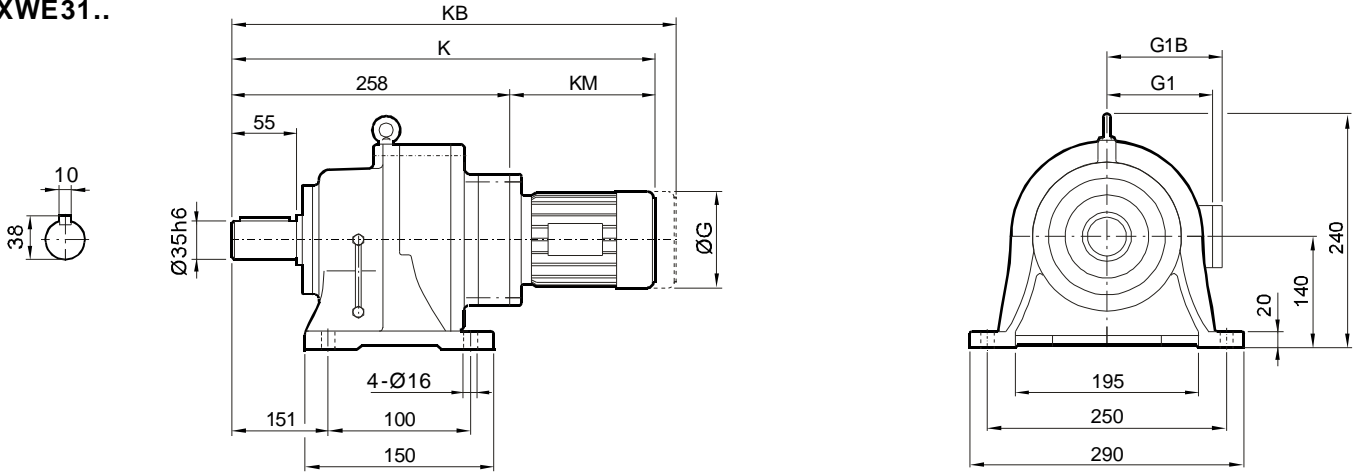

**XLE31..**

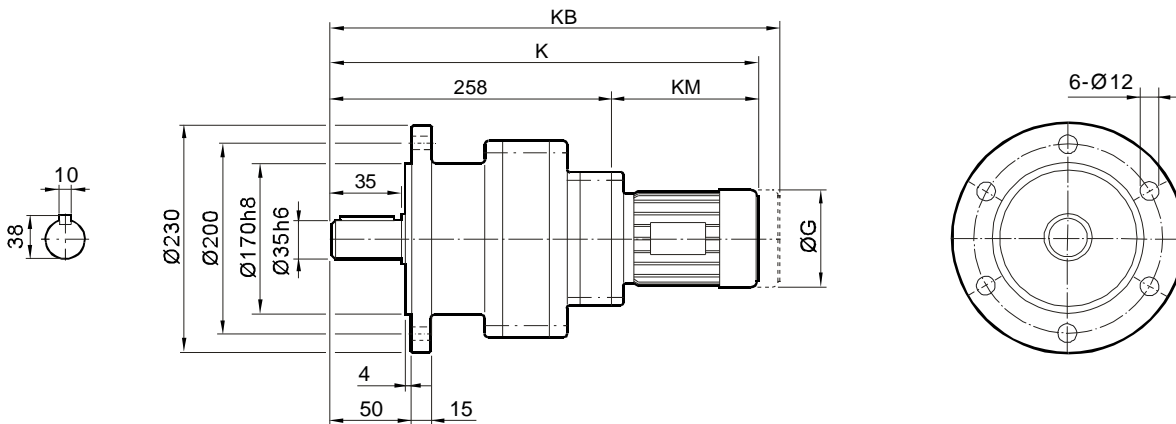

尺寸 Dimensions	电机规格 Motor frame									
	63	71	80							
<b>G</b>	132	145	175							
<b>G1</b>	99	122	145							
<b>G1B</b>	99	127	150							
<b>K</b>	407	422	472							
<b>KB</b>	483	519	549							
<b>KM</b>	149	164	214							

尺寸说明

以上尺寸为直联普通电机和制动电机尺寸；  
KB为制动电机尺寸,其余为普通电机尺寸；  
防爆电机，变频电机等须加过渡法兰，见171,172页。

**ATTENTION**

Dimensions of universal and brake motor shown in upon table,  
the others like explosion, inverter motor coupled by adaptor,  
the dimensions on page 171,172.



安装尺寸

Mounting Dimensions

**XWE42..**

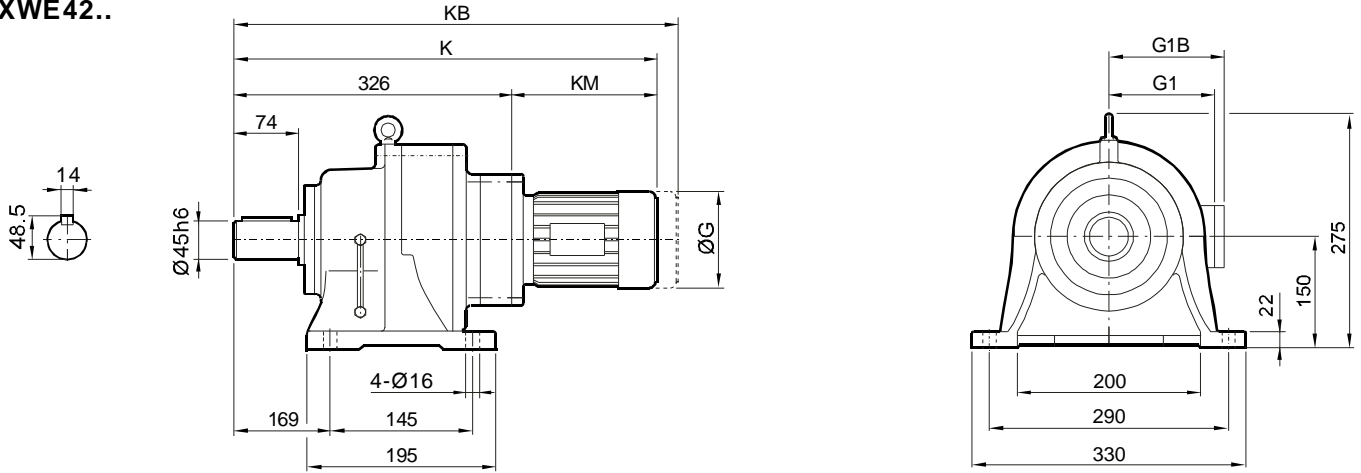

**XLE42..**

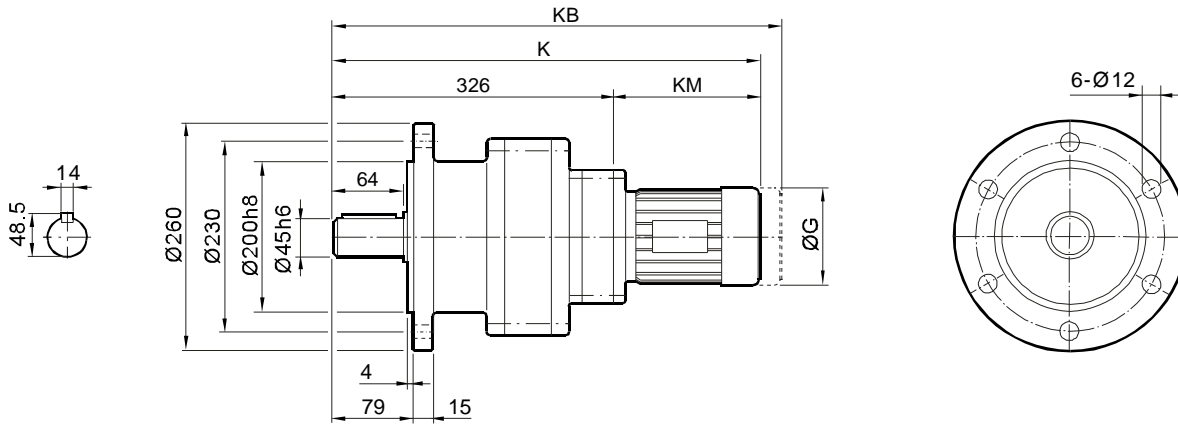

尺寸 Dimensions	电机规格 Motor frame									
	63	71	80	90						
<b>G</b>	132	145	175	197						
<b>G1</b>	99	122	145	154						
<b>G1B</b>	99	127	150	161						
<b>K</b>	517	532	582	602						
<b>KB</b>	593	629	659	726						
<b>KM</b>	191	206	256	276						

尺寸说明

以上尺寸为直联普通电机和制动电机尺寸；  
KB为制动电机尺寸,其余为普通电机尺寸；  
防爆电机，变频电机等须加过渡法兰，见171,172页。

**ATTENTION**

Dimensions of univeral and brake motor shown in upon table,  
the others like explosion, inverter motor coupled by adaptor,  
the dimensions on page 171,172.



安装尺寸

Mounting Dimensions

**BWE1812..**

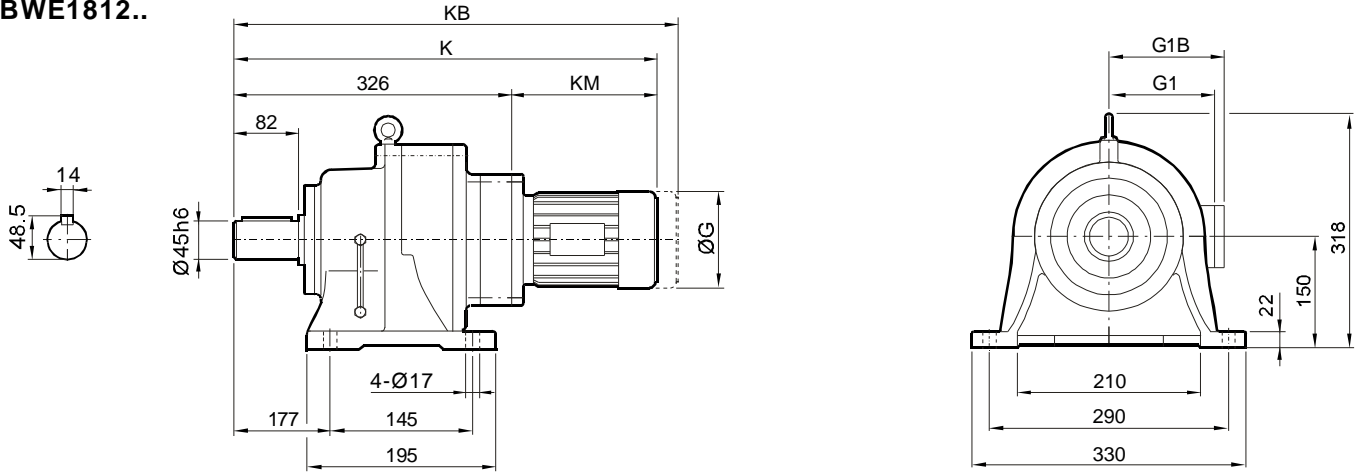

**BLE1812..**

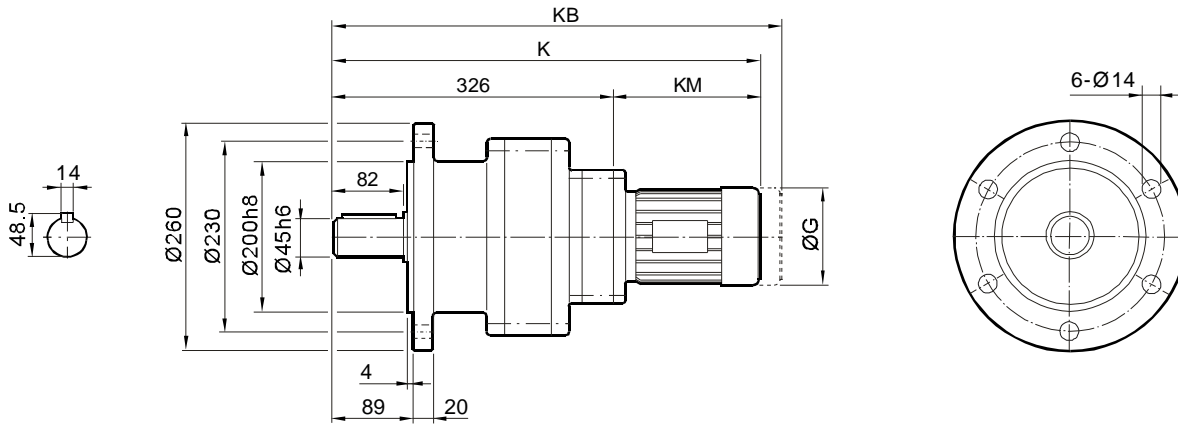

尺寸 Dimensions	电机规格 Motor frame									
	63	71	80	90						
<b>G</b>	132	145	175	197						
<b>G1</b>	99	122	145	154						
<b>G1B</b>	99	127	150	161						
<b>K</b>	549	564	614	634						
<b>KB</b>	604	628	678	719						
<b>KM</b>	191	206	256	276						

尺寸说明

以上尺寸为直联普通电机和制动电机尺寸；  
KB为制动电机尺寸,其余为普通电机尺寸；  
防爆电机，变频电机等须加过渡法兰，见171,172页。

**ATTENTION**

Dimensions of universal and brake motor shown in upon table,  
the others like explosion, inverter motor coupled by adaptor,  
the dimensions on page 171,172.



安装尺寸

Mounting Dimensions

**XWE53..**

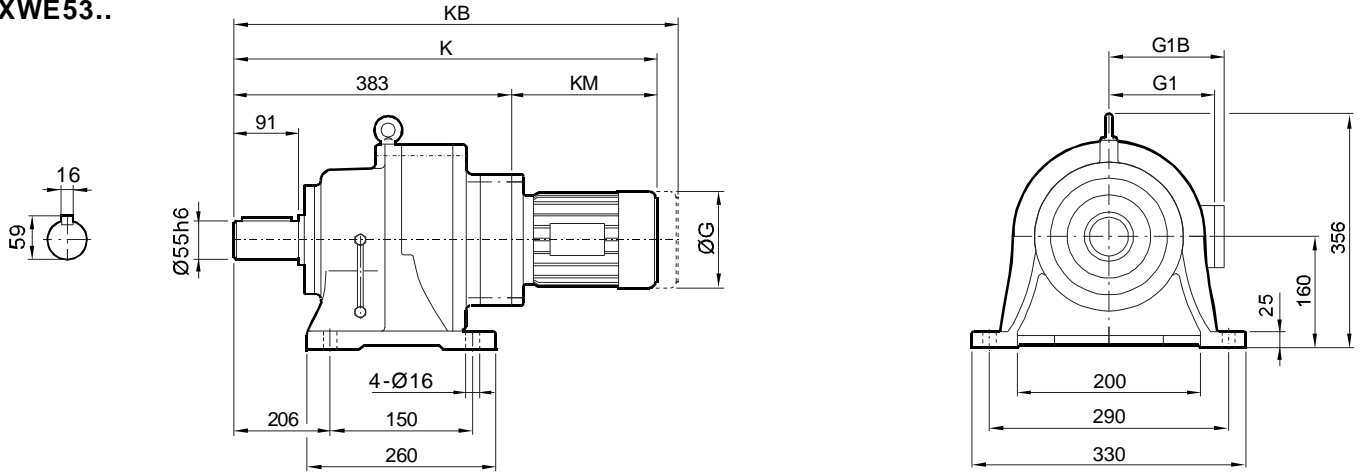

**XLE53..**

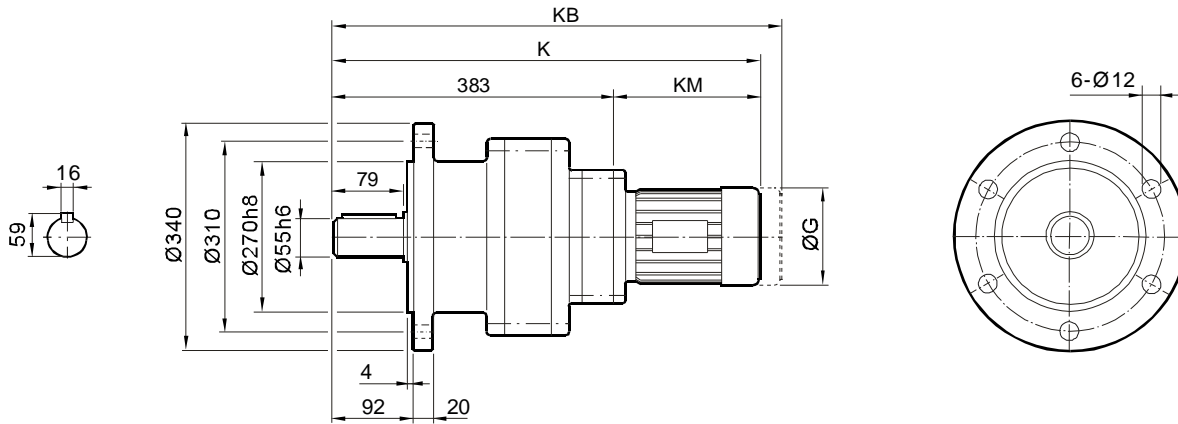

尺寸 Dimensions	电机规格 Motor frame									
	80	90	100							
<b>G</b>	175	197	197							
<b>G1</b>	145	154	166							
<b>G1B</b>	150	161	166							
<b>K</b>	632	652	702							
<b>KB</b>	707	731	799							
<b>KM</b>	249	269	319							

尺寸说明

以上尺寸为直联普通电机和制动电机尺寸；  
KB为制动电机尺寸,其余为普通电机尺寸；  
防爆电机，变频电机等须加过渡法兰，见171,172页。

**ATTENTION**

Dimensions of univeral and brake motor shown in upon table,  
the others like explosion, inverter motor coupled by adaptor,  
the dimensions on page 171,172.



安装尺寸

Mounting Dimensions

**BWE2215..**

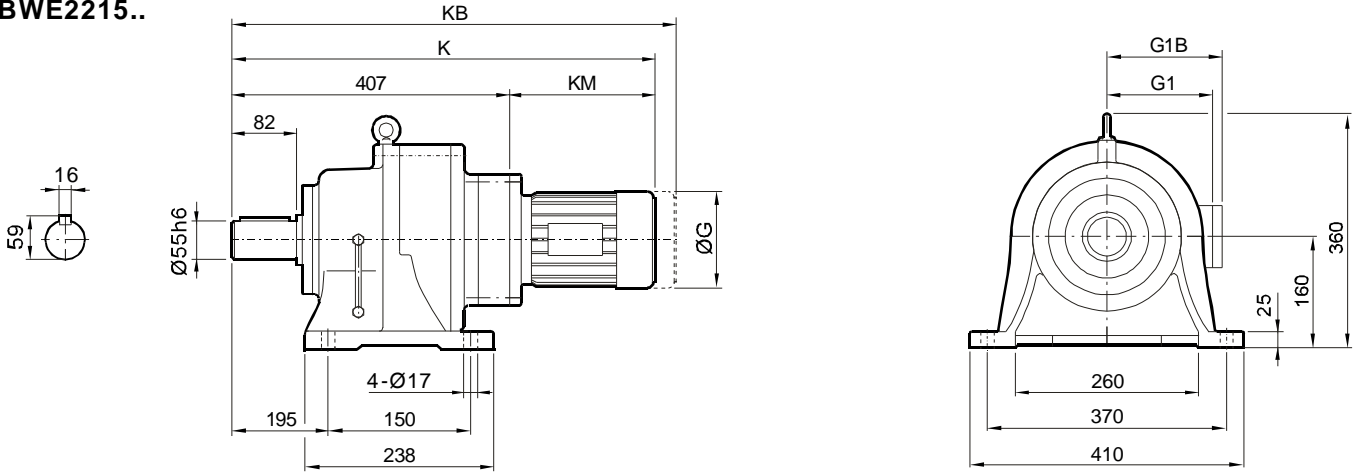

**BLE2215..**

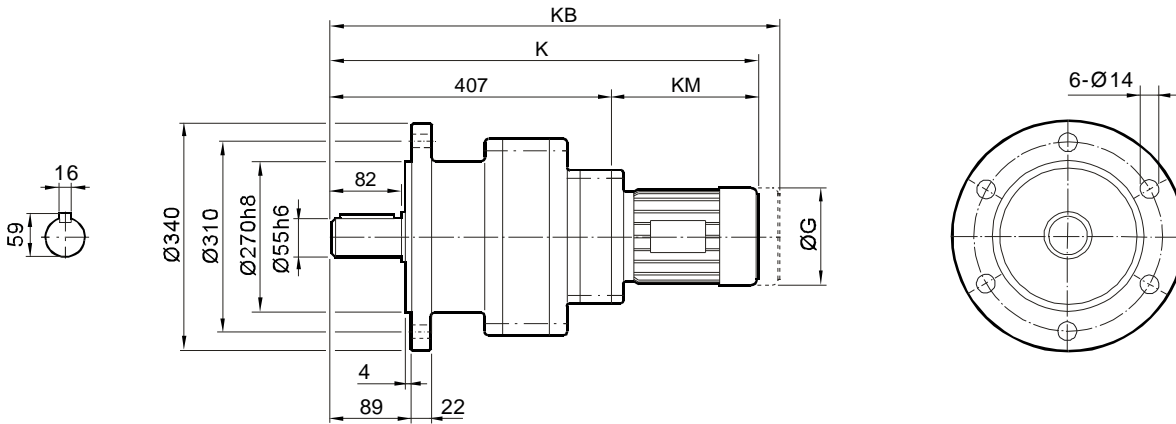

尺寸 Dimensions	电机规格 Motor frame									
	80	90	100							
<b>G</b>	175	197	197							
<b>G1</b>	145	154	166							
<b>G1B</b>	150	161	166							
<b>K</b>	656	676	726							
<b>KB</b>	731	755	823							
<b>KM</b>	249	269	319							

尺寸说明

以上尺寸为直联普通电机和制动电机尺寸；  
KB为制动电机尺寸,其余为普通电机尺寸；  
防爆电机，变频电机等须加过渡法兰，见171,172页。

**ATTENTION**

Dimensions of univeral and brake motor shown in upon table,  
the others like explosion, inverter motor coupled by adaptor,  
the dimensions on page 171,172.



安装尺寸

Mounting Dimensions

**XWE63..**

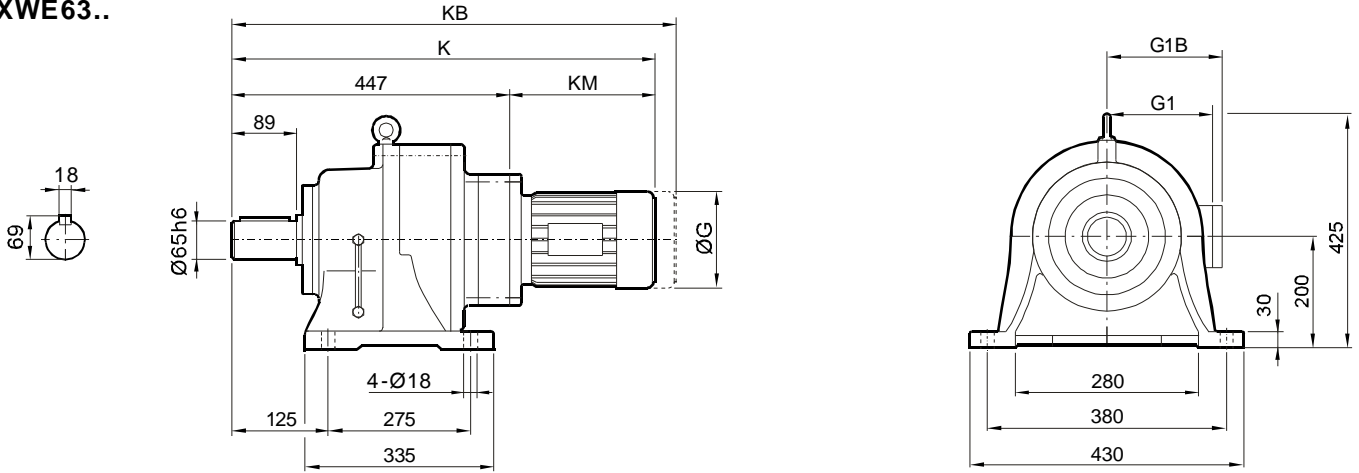

**XLE63..**

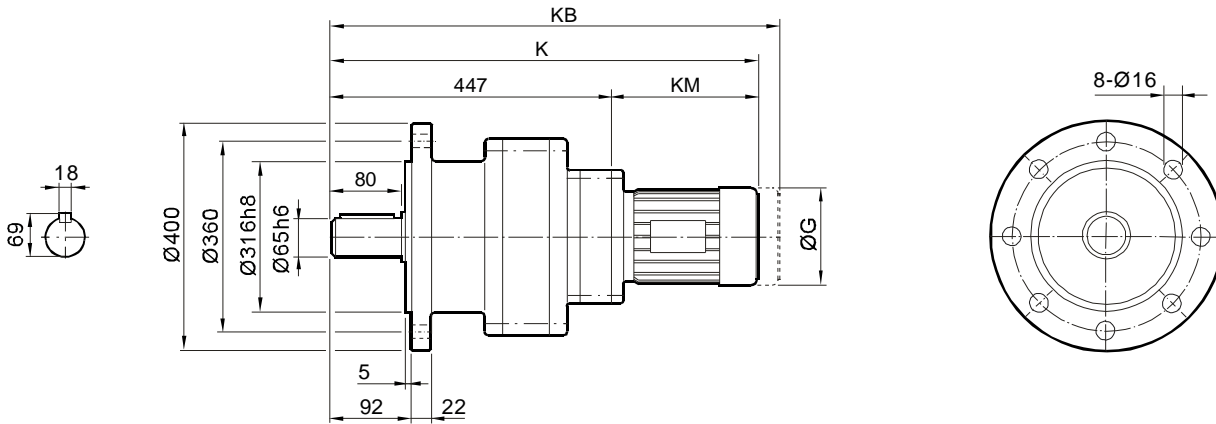

尺寸 Dimensions	电机规格 Motor frame									
	80	90	100							
<b>G</b>	175	197	197							
<b>G1</b>	145	154	166							
<b>G1B</b>	150	161	166							
<b>K</b>	696	716	766							
<b>KB</b>	771	795	863							
<b>KM</b>	249	269	319							

尺寸说明

以上尺寸为直联普通电机和制动电机尺寸；  
KB为制动电机尺寸,其余为普通电机尺寸；  
防爆电机，变频电机等须加过渡法兰，见171,172页。

**ATTENTION**

Dimensions of universal and brake motor shown in upon table,  
the others like explosion, inverter motor coupled by adaptor,  
the dimensions on page 171,172.



安装尺寸

Mounting Dimensions

**BWE2715..**

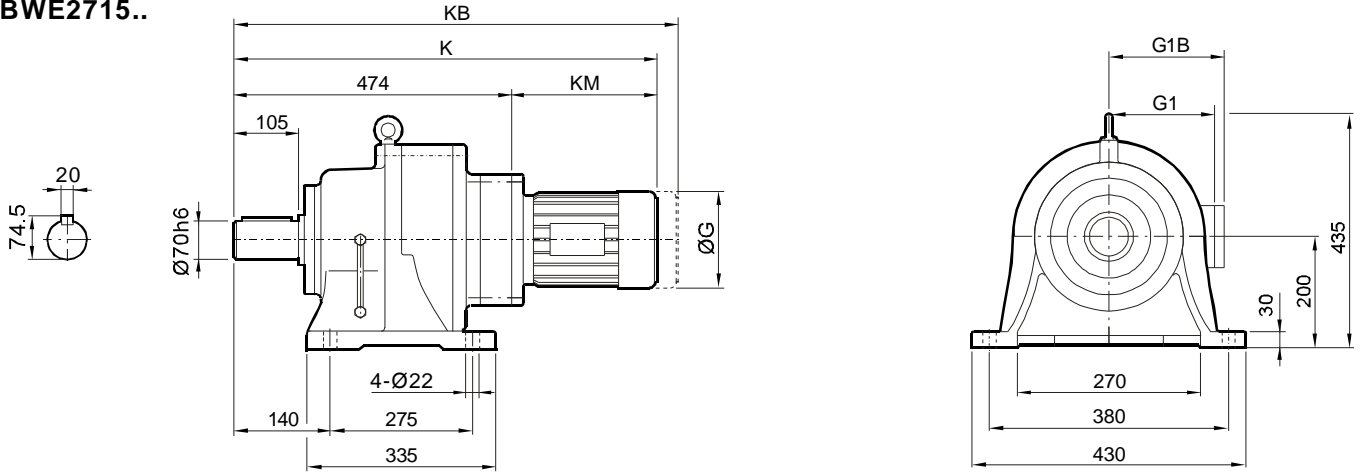

**BLE2715..**

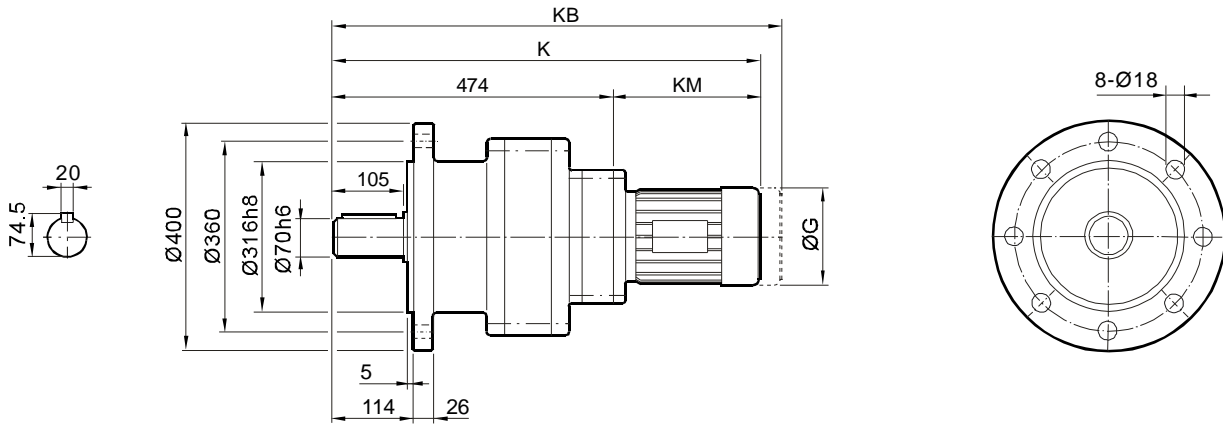

尺寸 Dimensions	电机规格 Motor frame									
	80	90	100							
<b>G</b>	175	197	197							
<b>G1</b>	145	154	166							
<b>G1B</b>	150	161	166							
<b>K</b>	663	683	733							
<b>KB</b>	738	762	830							
<b>KM</b>	249	269	319							

尺寸说明

以上尺寸为直联普通电机和制动电机尺寸；  
KB为制动电机尺寸,其余为普通电机尺寸；  
防爆电机，变频电机等须加过渡法兰，见171,172页。

**ATTENTION**

Dimensions of univeral and brake motor shown in upon table,  
the others like explosion, inverter motor coupled by adaptor,  
the dimensions on page 171,172.



安装尺寸

Mounting Dimensions

**XWE74..**

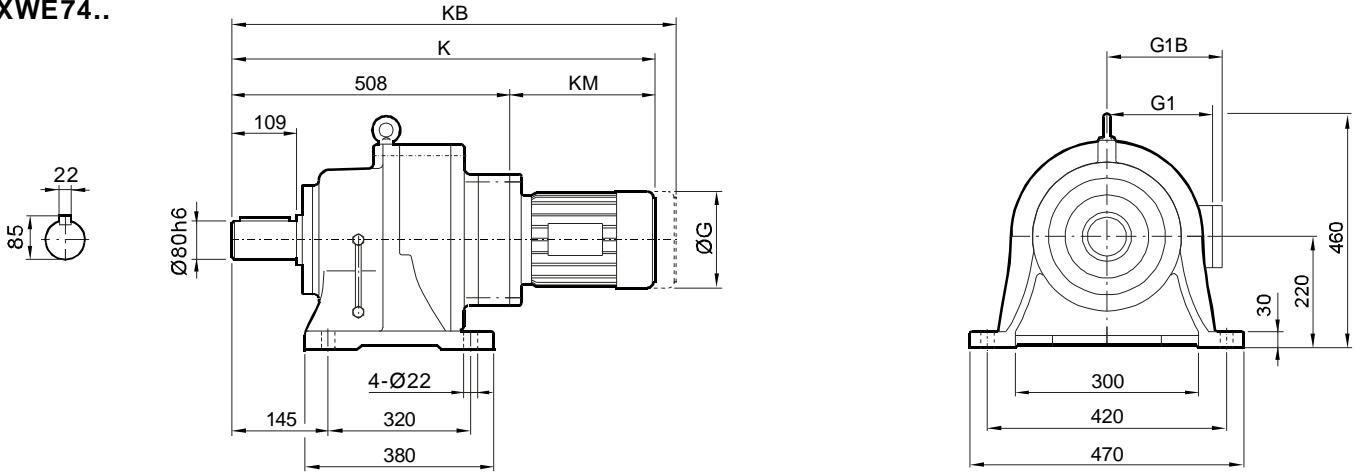

**XLE74..**

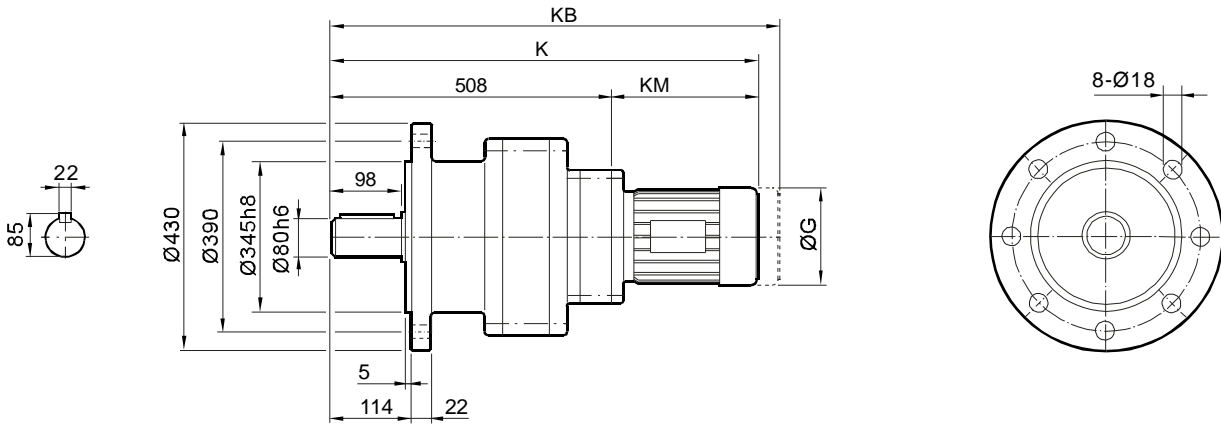

尺寸 Dimensions	电机规格 Motor frame									
	80	90	100	112						
<b>G</b>	175	197	215	240						
<b>G1</b>	145	154	175	185						
<b>G1B</b>	150	161	180	190						
<b>K</b>	757	777	827	862						
<b>KB</b>	876	921	924	962						
<b>KM</b>	249	269	319	354						

尺寸说明

以上尺寸为直联普通电机和制动电机尺寸；  
KB为制动电机尺寸,其余为普通电机尺寸；  
防爆电机，变频电机等须加过渡法兰，见171,172页。

**ATTENTION**

Dimensions of universal and brake motor shown in upon table,  
the others like explosion, inverter motor coupled by adaptor,  
the dimensions on page 171,172.



安装尺寸

Mounting Dimensions

**XWE84..**

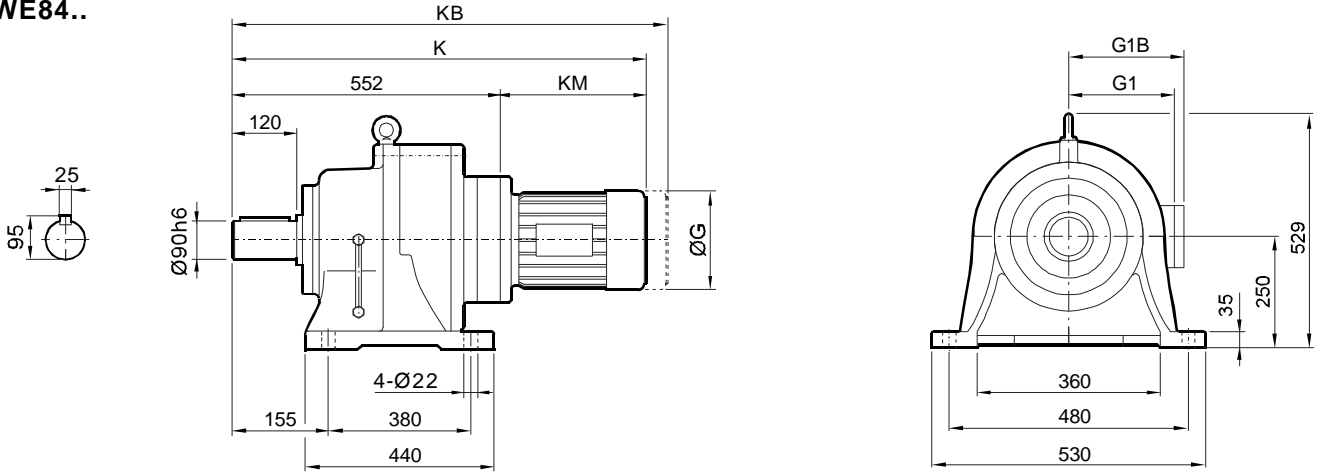

**XLE84..**

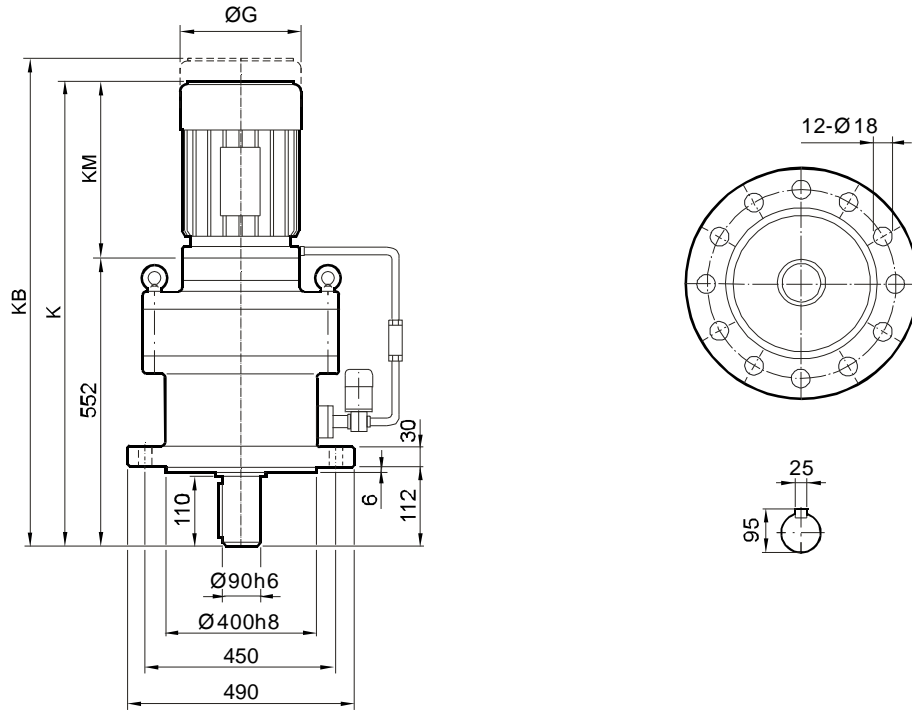

尺寸 Dimensions	电机规格 Motor frame									
	80	90	100	112						
<b>G</b>	175	197	215	240						
<b>G1</b>	145	154	175	185						
<b>G1B</b>	150	161	180	190						
<b>K</b>	801	821	871	906						
<b>KB</b>	920	965	968	1006						
<b>KM</b>	249	269	319	354						

尺寸说明

以上尺寸为直联普通电机和制动电机尺寸；  
KB为制动电机尺寸,其余为普通电机尺寸；  
防爆电机，变频电机等须加过渡法兰，见171,172页。

**ATTENTION**

Dimensions of universal and brake motor shown in upon table,  
the others like explosion, inverter motor coupled by adaptor,  
the dimensions on page 171,172.



安装尺寸

Mounting Dimensions

**BWE3318..**

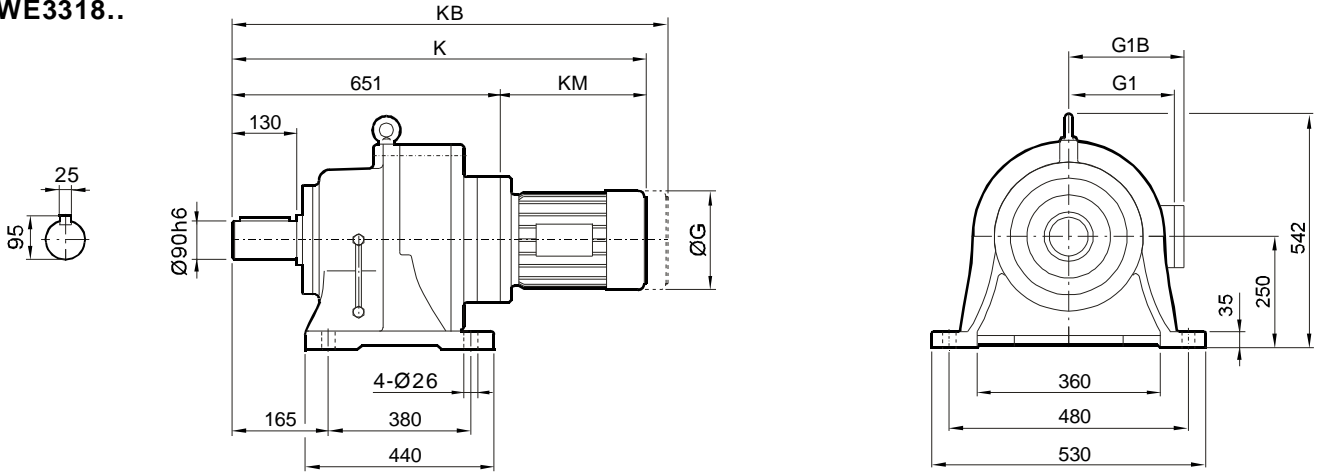

**BLE3318..**

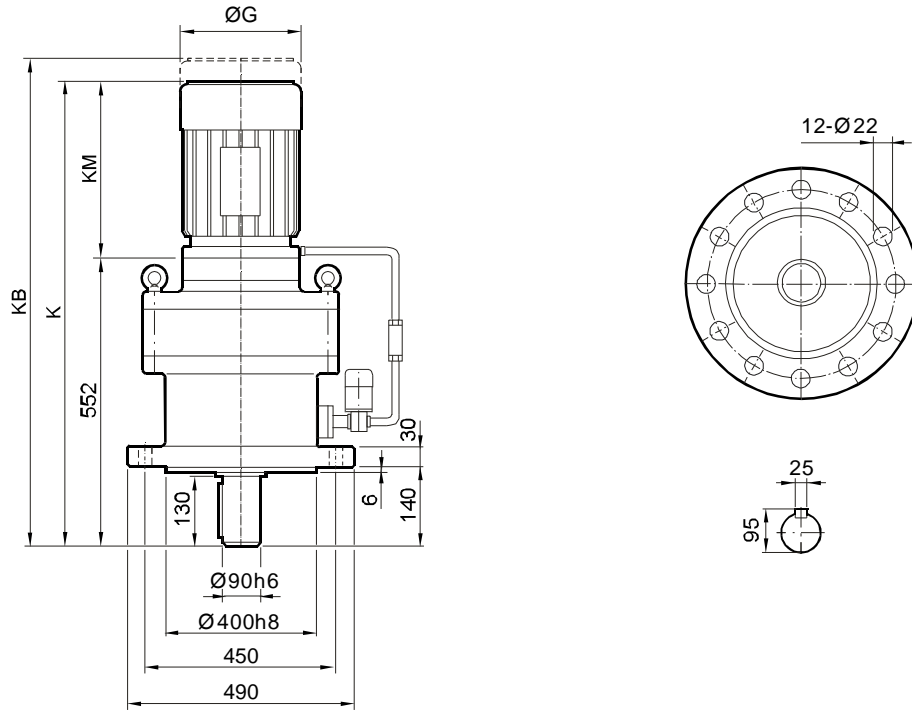

尺寸 Dimensions	电机规格 Motor frame									
	80	90	100	112						
<b>G</b>	175	197	215	240						
<b>G1</b>	145	154	175	185						
<b>G1B</b>	150	161	180	190						
<b>K</b>	900	920	970	1005						
<b>KB</b>	975	999	1067	1105						
<b>KM</b>	249	269	319	354						

尺寸说明

以上尺寸为直联普通电机和制动电机尺寸；  
KB为制动电机尺寸,其余为普通电机尺寸；  
防爆电机，变频电机等须加过渡法兰，见171,172页。

**ATTENTION**

Dimensions of universal and brake motor shown in upon table,  
the others like explosion, inverter motor coupled by adaptor,  
the dimensions on page 171,172.



安装尺寸

Mounting Dimensions

**XWE85..**

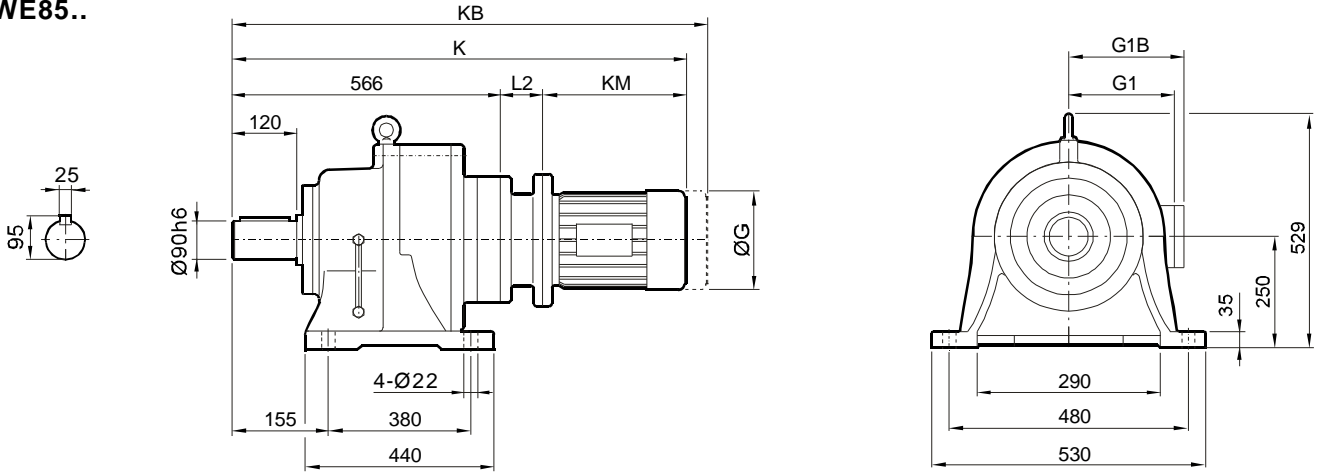

**XLE85..**

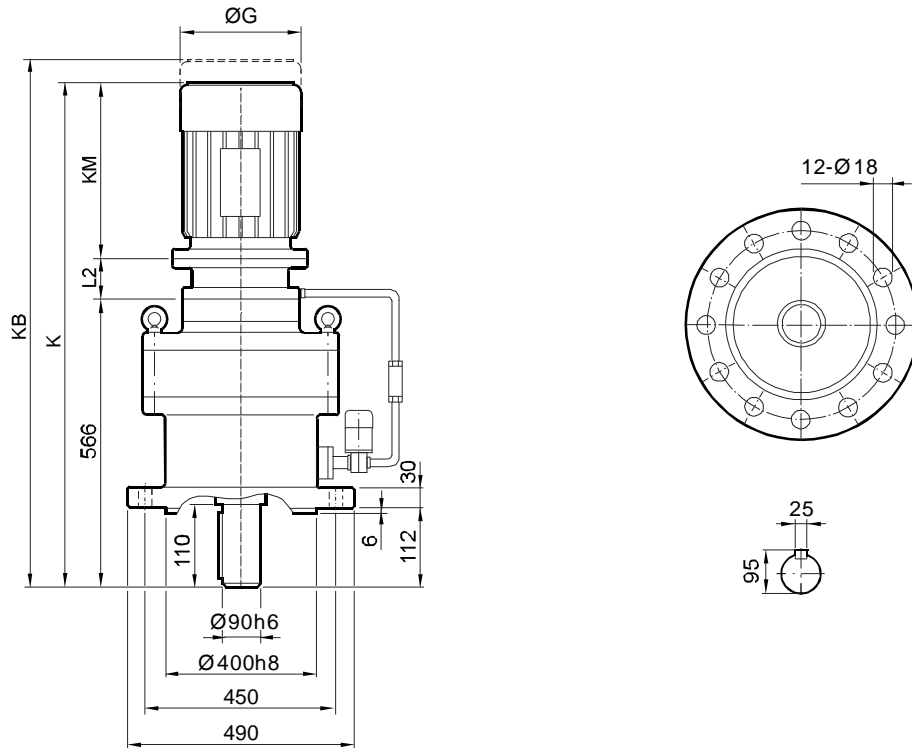

尺寸 Dimensions	电机规格 Motor frame										
	90	100	112	132S	132M	160M					
<b>G</b>	197	215	240	275	275	330					
<b>G1</b>	154	175	185	205	205	255					
<b>G1B</b>	161	180	190	230	230	280					
<b>K</b>	925	1024	1028	1118	1118	1208					
<b>KB</b>	1004	1121	1128	1236	1236	1362					
<b>KM</b>	261	341	345	412	412	472					
<b>L2</b>	101	117	117	140	140	170					

尺寸说明

以上尺寸为直联普通电机和制动电机尺寸；  
KB为制动电机尺寸,其余为普通电机尺寸；  
防爆电机，变频电机等须加过渡法兰，见171,172页。

**ATTENTION**

Dimensions of universal and brake motor shown in upon table,  
the others like explosion, inverter motor coupled by adaptor,  
the dimensions on page 171,172.



安装尺寸

Mounting Dimensions

**BWE3322..**

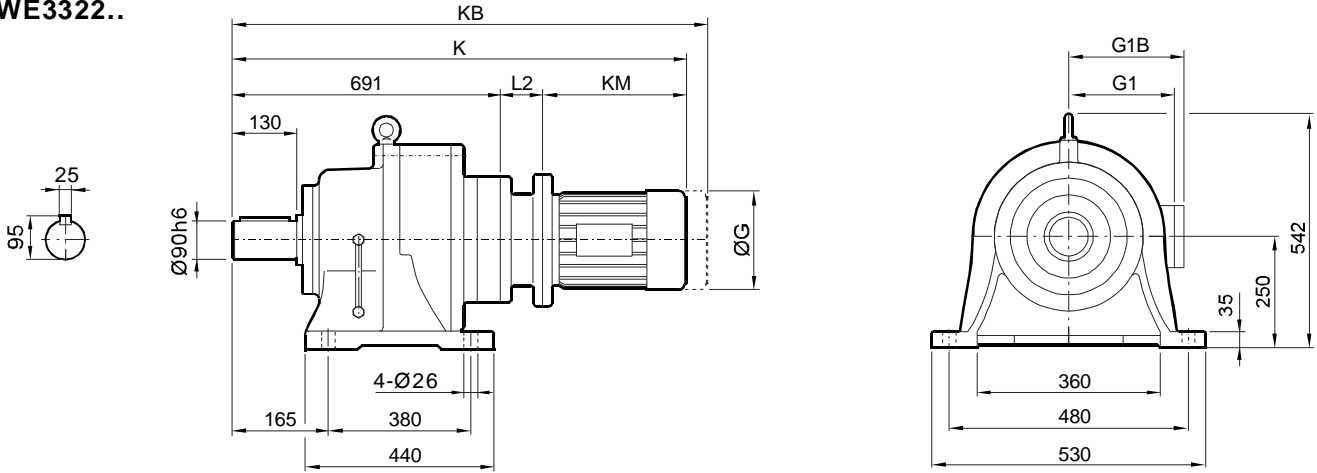

**BLE3322..**

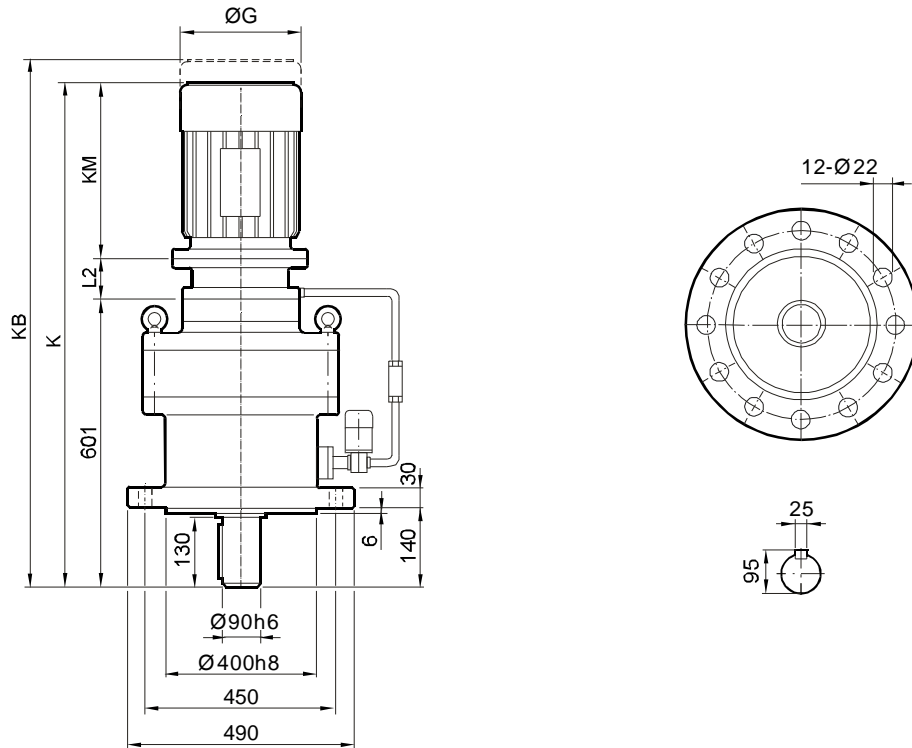

尺寸 Dimensions	电机规格 Motor frame										
	90	100	112	132S	132M	160M					
<b>G</b>	197	215	240	275	275	330					
<b>G1</b>	154	175	185	205	205	255					
<b>G1B</b>	161	180	190	230	230	280					
<b>K</b>	1050	1149	1153	1243	1243	1333					
<b>KB</b>	1129	1246	1253	1361	1361	1487					
<b>KM</b>	261	341	345	412	412	472					
<b>L2</b>	101	117	117	140	140	170					

尺寸说明

以上尺寸为直联普通电机和制动电机尺寸；

KB为制动电机尺寸,其余为普通电机尺寸；

防爆电机, 变频电机等须加过渡法兰, 见171,172页。

**ATTENTION**

Dimensions of universal and brake motor shown in upon table, the others like explosion, inverter motor coupled by adaptor, the dimensions on page 171,172.



安装尺寸

Mounting Dimensions

**XWE95..**

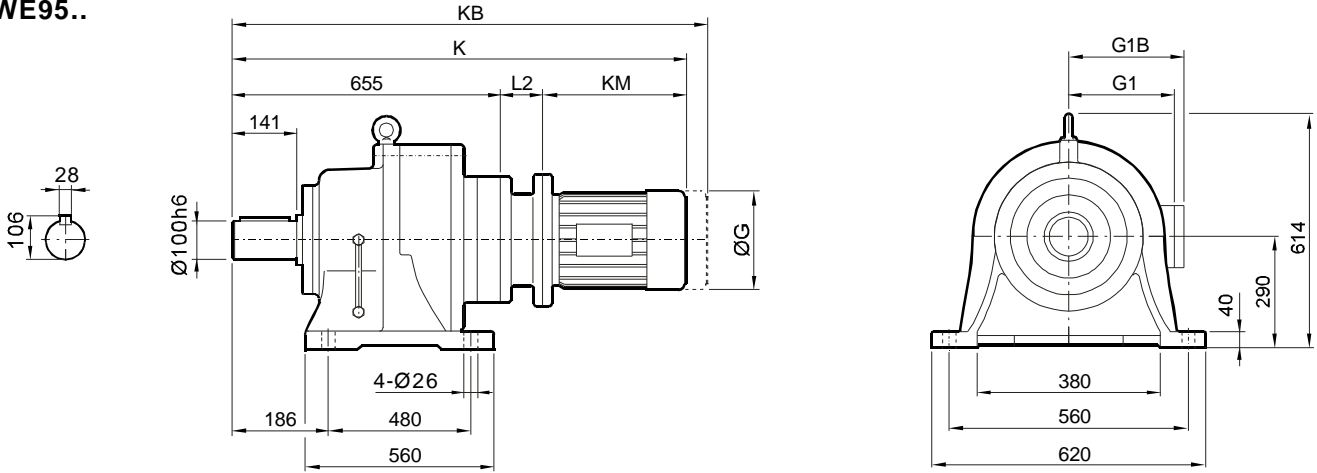

**XLE95..**

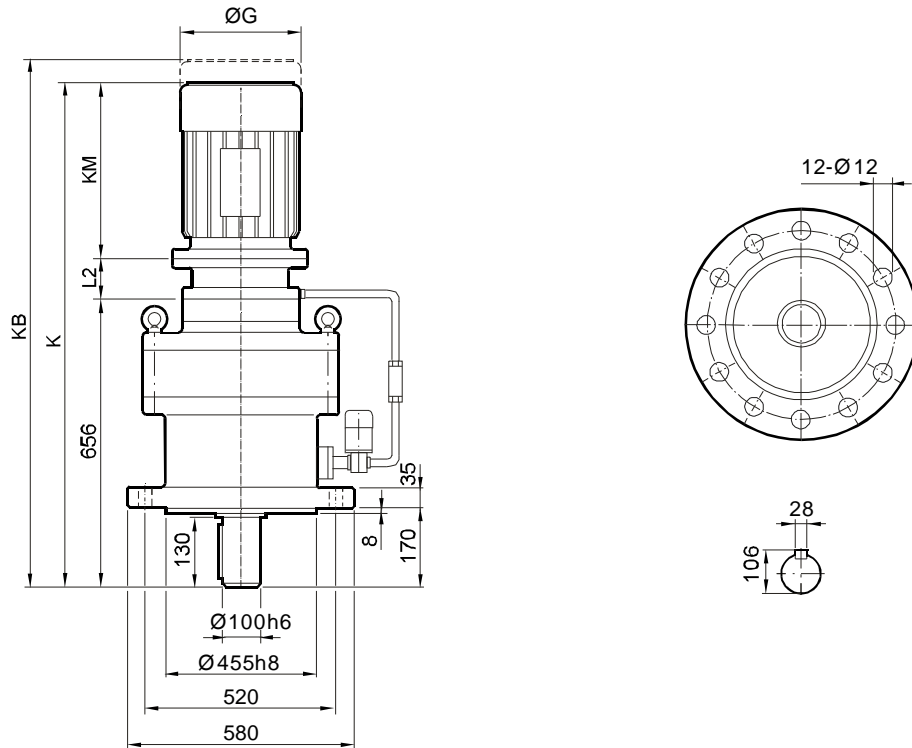

尺寸 Dimensions	电机规格 Motor frame											
	90	100	112	132S	132M	160M						
<b>G</b>	197	215	240	275	275	330						
<b>G1</b>	154	175	185	205	205	255						
<b>G1B</b>	161	180	190	230	230	280						
<b>K</b>	1014	1113	1117	1207	1207	1297						
<b>KB</b>	1093	1210	1217	1325	1325	1451						
<b>KM</b>	261	341	345	412	412	472						
<b>L2</b>	101	117	117	140	140	170						

尺寸说明

以上尺寸为直联普通电机和制动电机尺寸；  
KB为制动电机尺寸,其余为普通电机尺寸；  
防爆电机，变频电机等须加过渡法兰，见171,172页。

**ATTENTION**

Dimensions of universal and brake motor shown in upon table,  
the others like explosion, inverter motor coupled by adaptor,  
the dimensions on page 171,172.



安装尺寸

Mounting Dimensions

**BWE3922..**

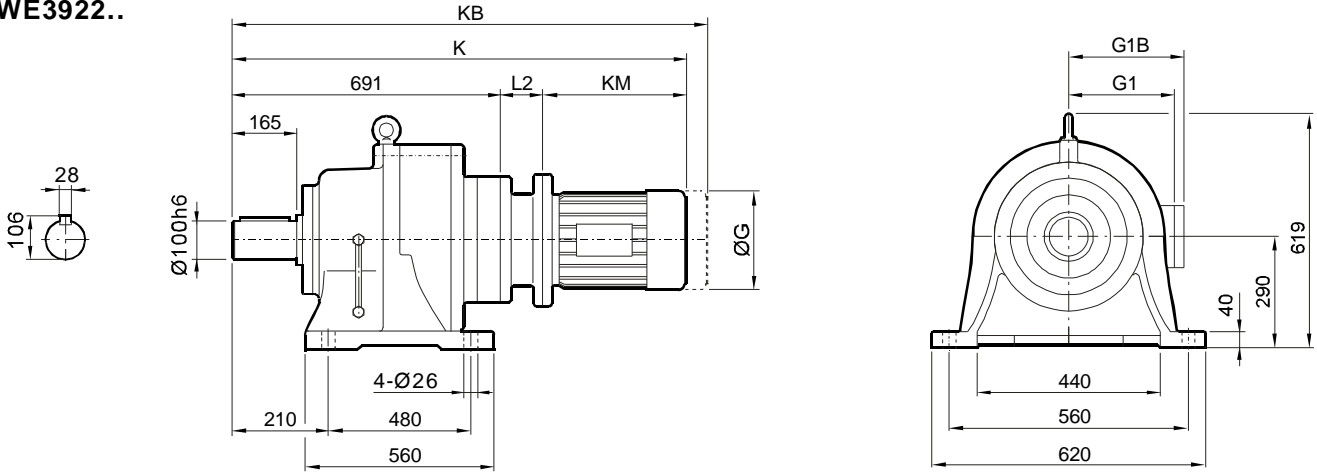

**BLE3922..**

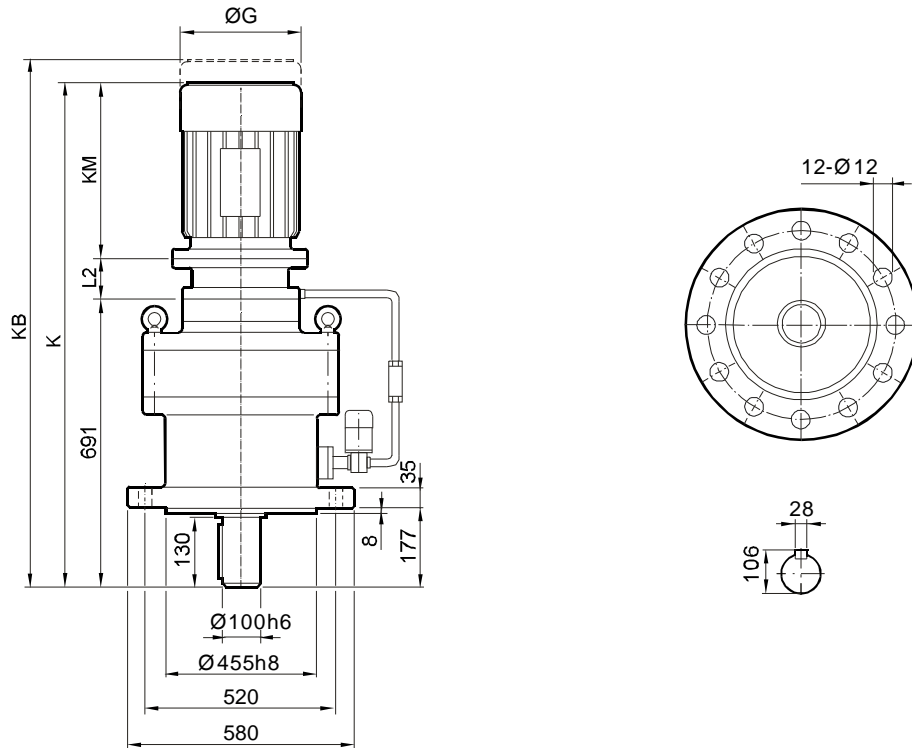

尺寸 Dimensions	电机规格 Motor frame										
	90	100	112	132S	132M	160M					
<b>G</b>	197	215	240	275	275	330					
<b>G1</b>	154	175	185	205	205	255					
<b>G1B</b>	161	180	190	230	230	280					
<b>K</b>	1050	1149	1153	1243	1243	1333					
<b>KB</b>	1129	1246	1253	1361	1361	1487					
<b>KM</b>	261	341	345	412	412	472					
<b>L2</b>	101	117	117	140	140	170					

尺寸说明

以上尺寸为直联普通电机和制动电机尺寸；

KB为制动电机尺寸,其余为普通电机尺寸；

防爆电机, 变频电机等须加过渡法兰, 见171,172页。

**ATTENTION**

Dimensions of universal and brake motor shown in upon table, the others like explosion, inverter motor coupled by adaptor, the dimensions on page 171,172.



安装尺寸

Mounting Dimensions

**XWE106..**

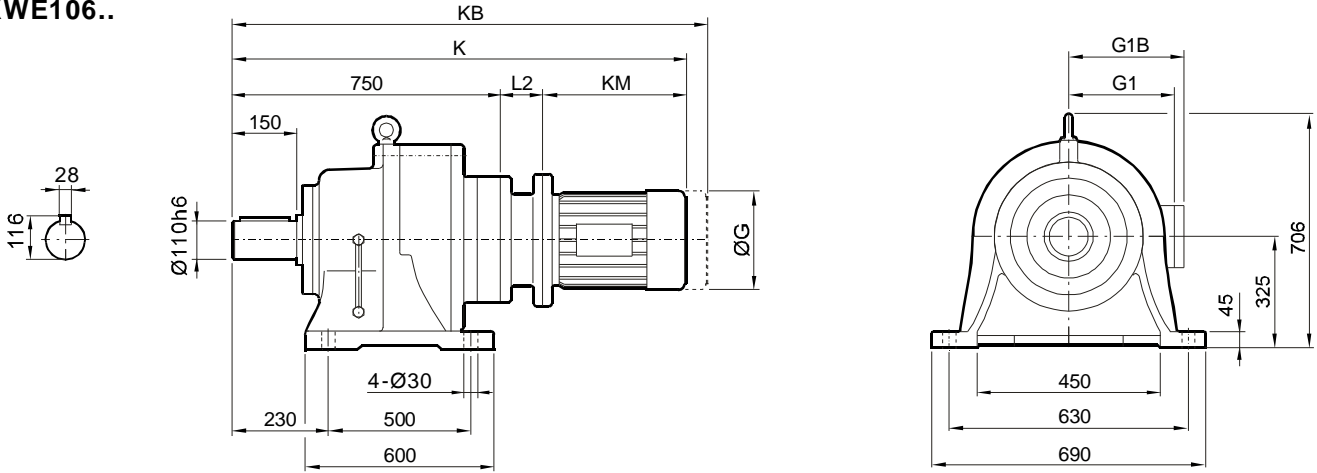

**XLE106..**

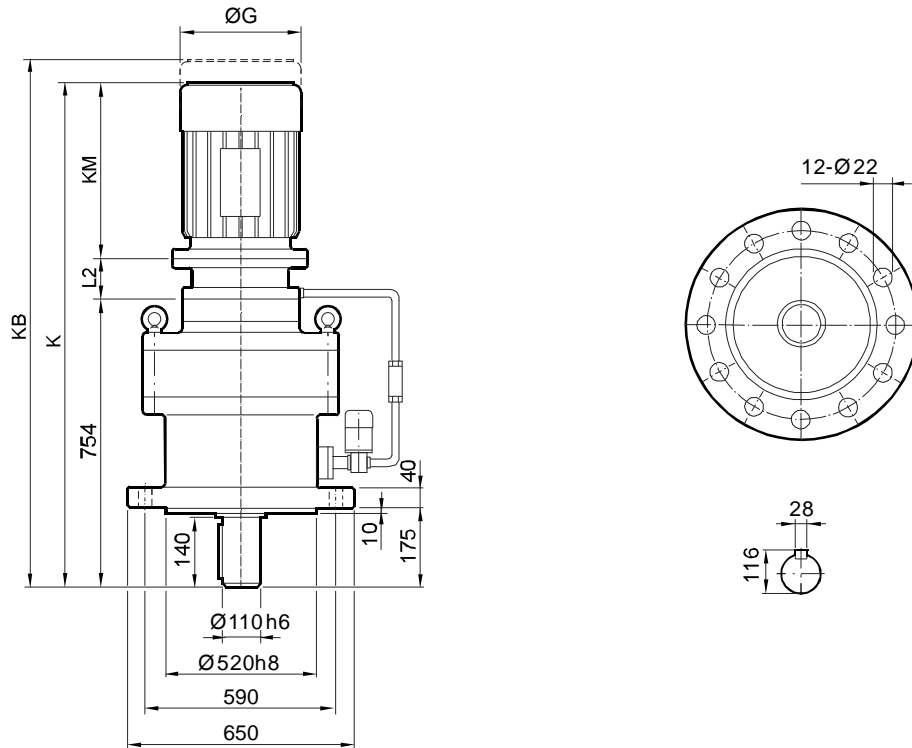

尺寸 Dimensions	电机规格 Motor frame										
	100	112	132S	132M	160M	160L					
<b>G</b>	215	240	275	275	330	330					
<b>G1</b>	175	185	205	205	255	255					
<b>G1B</b>	180	190	230	230	280	280					
<b>K</b>	1204	1208	1304	1304	1401	1456					
<b>KB</b>	1301	1308	1422	1422	1555	1610					
<b>KM</b>	341	345	412	412	472	527					
<b>L2</b>	113	113	142	142	179	179					

尺寸说明

以上尺寸为直联普通电机和制动电机尺寸；

KB为制动电机尺寸,其余为普通电机尺寸；

防爆电机, 变频电机等须加过渡法兰, 见171,172页。

**ATTENTION**

Dimensions of universal and brake motor shown in upon table, the others like explosion, inverter motor coupled by adaptor, the dimensions on page 171,172.



安装尺寸

Mounting Dimensions

**BWE4527..**

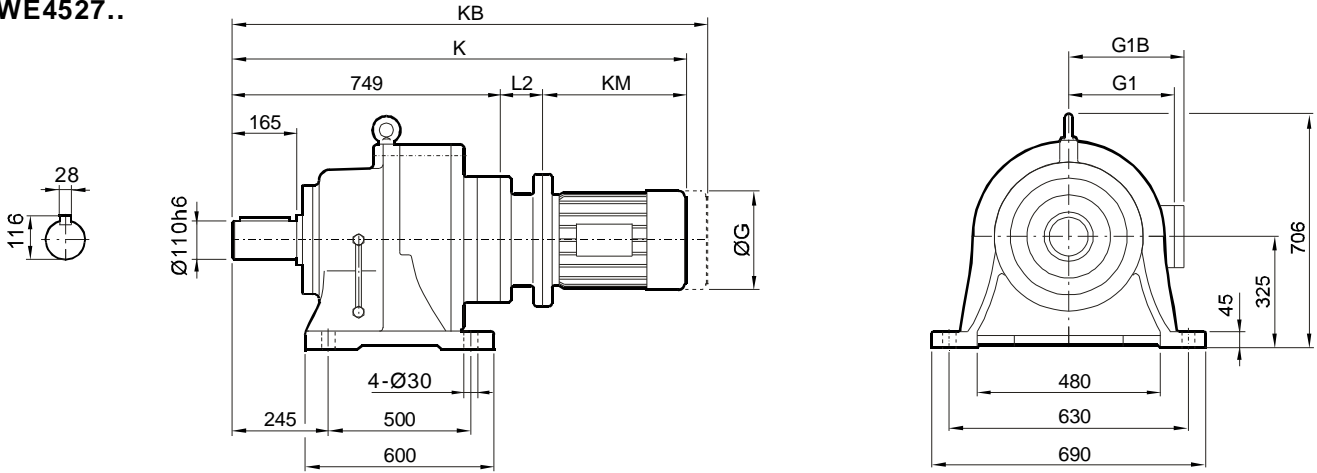

**BLE4527..**

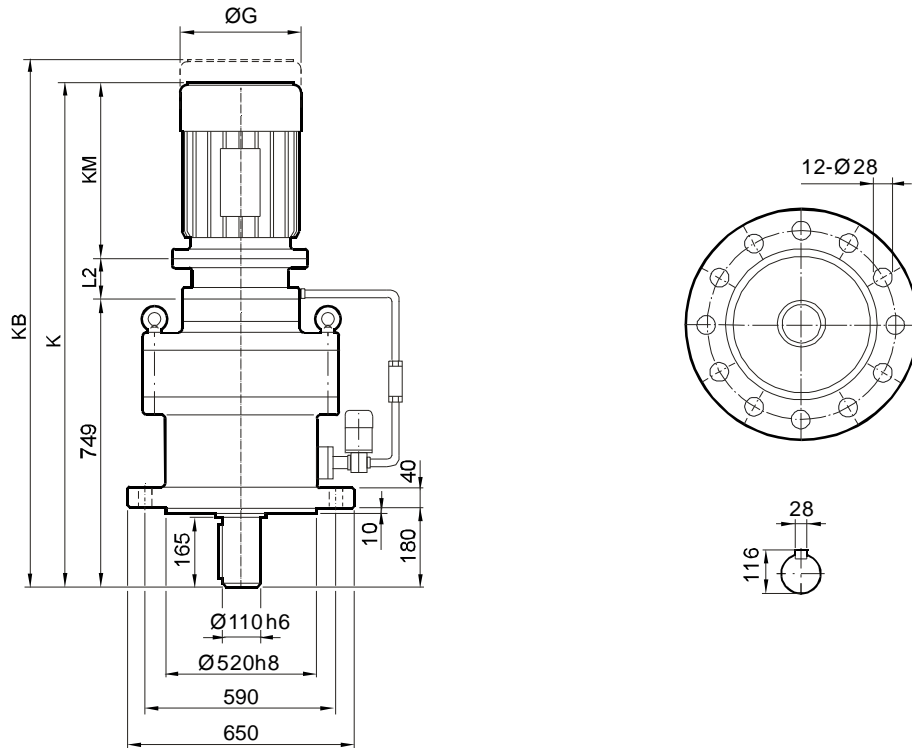

尺寸 Dimensions	电机规格 Motor frame										
	100	112	132S	132M	160M	160L					
<b>G</b>	215	240	275	275	330	330					
<b>G1</b>	175	185	205	205	255	255					
<b>G1B</b>	180	190	230	230	280	280					
<b>K</b>	1203	1207	1303	1303	1400	1455					
<b>KB</b>	1300	1307	1421	1421	1556	1609					
<b>KM</b>	341	345	412	412	472	527					
<b>L2</b>	113	113	142	142	179	179					

尺寸说明

以上尺寸为直联普通电机和制动电机尺寸；  
KB为制动电机尺寸,其余为普通电机尺寸；  
防爆电机，变频电机等须加过渡法兰，见171,172页。

**ATTENTION**

Dimensions of universal and brake motor shown in upon table,  
the others like explosion, inverter motor coupled by adaptor,  
the dimensions on page 171,172.



安装尺寸

Mounting Dimensions

**XWE116..**

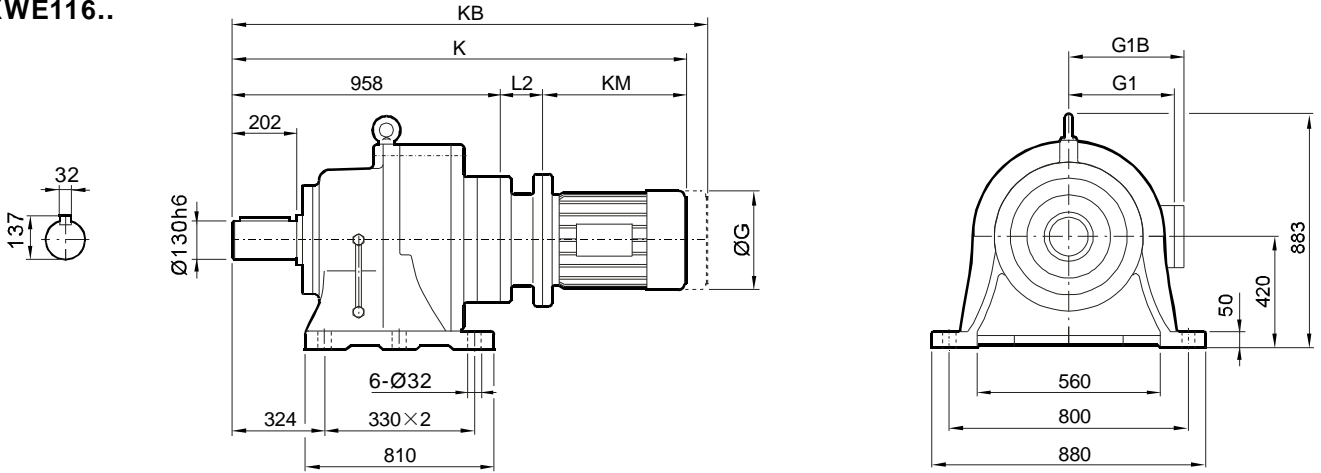

**XLE116..**

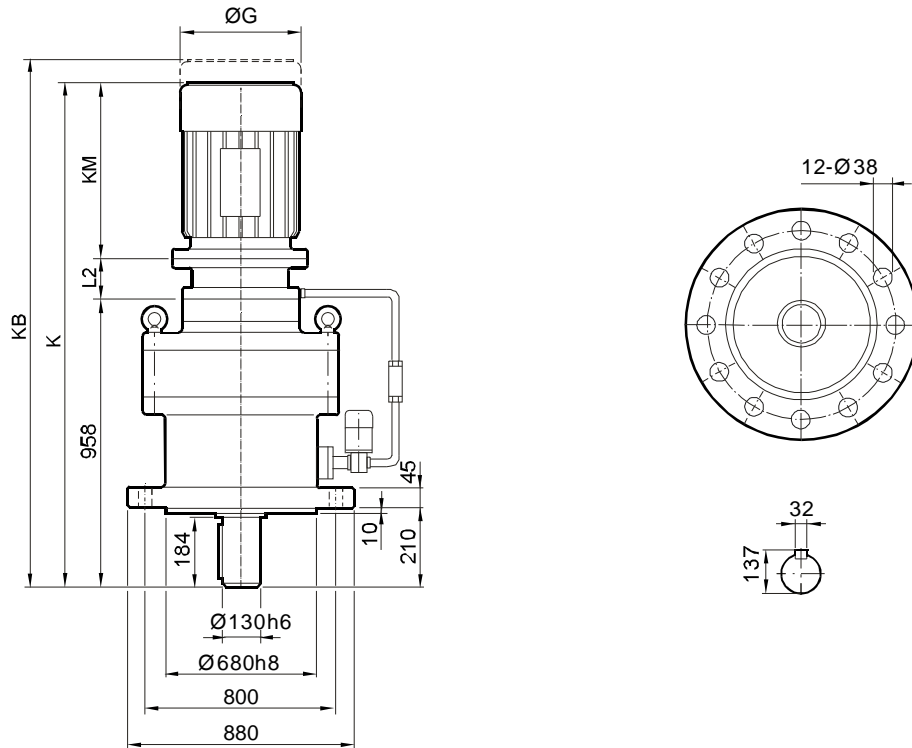

尺寸 Dimensions	电机规格 Motor frame										
	100	112	132S	132M	160M	160L					
<b>G</b>	215	240	275	275	330	330					
<b>G1</b>	175	185	205	205	255	255					
<b>G1B</b>	180	190	230	230	280	280					
<b>K</b>	1412	1416	1512	1512	1609	1664					
<b>KB</b>	1509	1516	1630	1630	1763	1818					
<b>KM</b>	341	345	412	412	472	527					
<b>L2</b>	113	113	142	142	179	179					

尺寸说明

以上尺寸为直联普通电机和制动电机尺寸；  
KB为制动电机尺寸,其余为普通电机尺寸；  
防爆电机，变频电机等须加过渡法兰，见171,172页。

**ATTENTION**

Dimensions of universal and brake motor shown in upon table,  
the others like explosion, inverter motor coupled by adaptor,  
the dimensions on page 171,172.



安装尺寸

Mounting Dimensions

**BWE5527..**

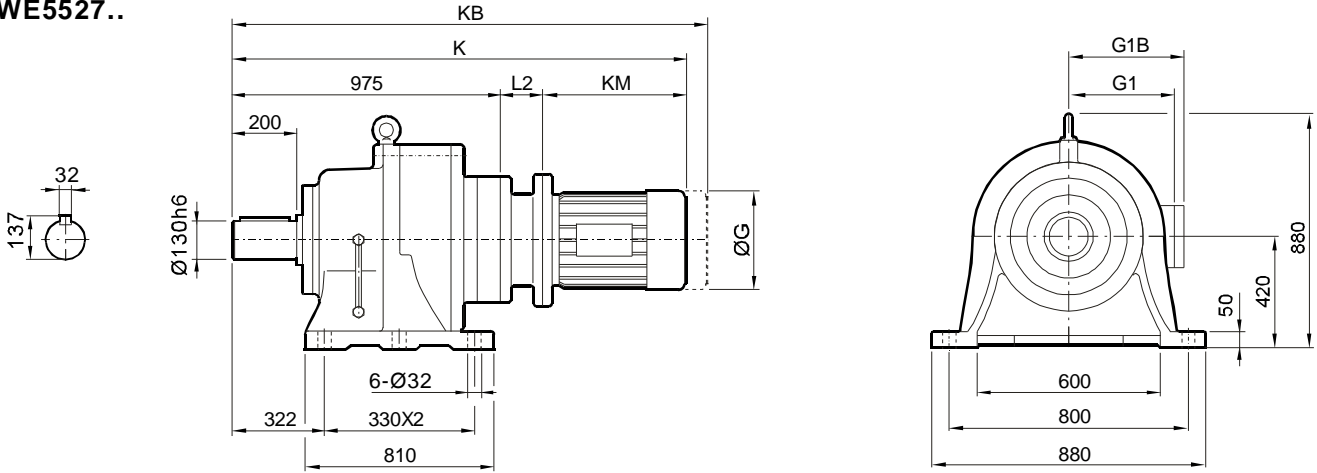

**BLE5527..**

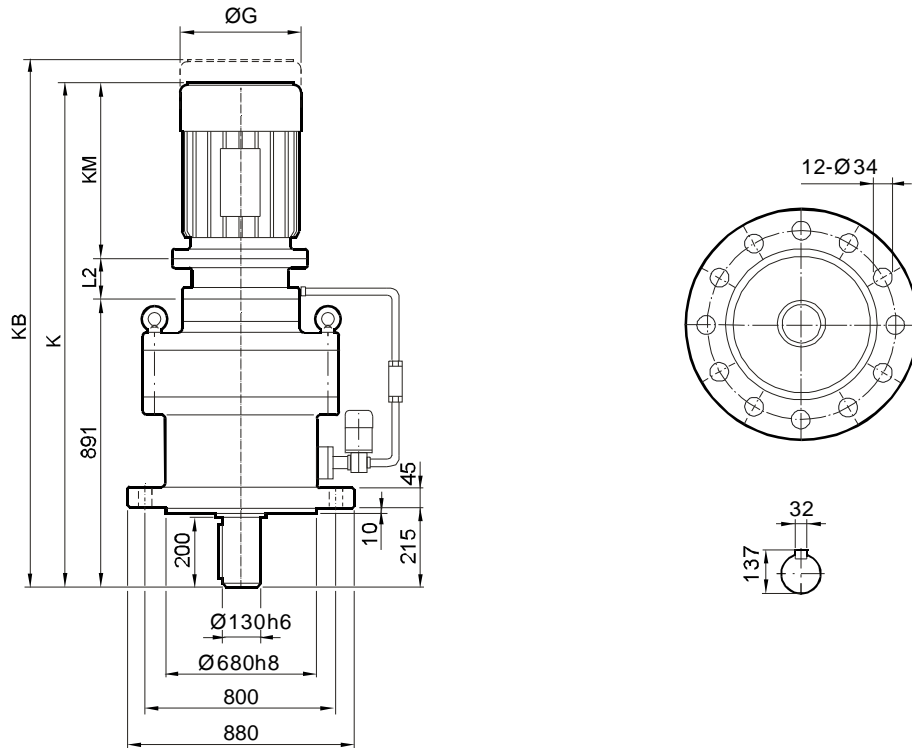

尺寸 Dimensions	电机规格 Motor frame										
	100	112	132S	132M	160M	160L					
<b>G</b>	215	240	275	275	330	330					
<b>G1</b>	175	185	205	205	255	255					
<b>G1B</b>	180	190	230	230	280	280					
<b>K</b>	1429	1433	1529	1529	1626	1681					
<b>KB</b>	1526	1533	1647	1647	1780	1835					
<b>KM</b>	341	345	412	412	472	527					
<b>L2</b>	113	113	142	142	179	179					

尺寸说明

以上尺寸为直联普通电机和制动电机尺寸；  
KB为制动电机尺寸,其余为普通电机尺寸；  
防爆电机，变频电机等须加过渡法兰，见171,172页。

**ATTENTION**

Dimensions of universal and brake motor shown in upon table,  
the others like explosion, inverter motor coupled by adaptor,  
the dimensions on page 171,172.



安装尺寸

Mounting Dimensions

**XWE117..**

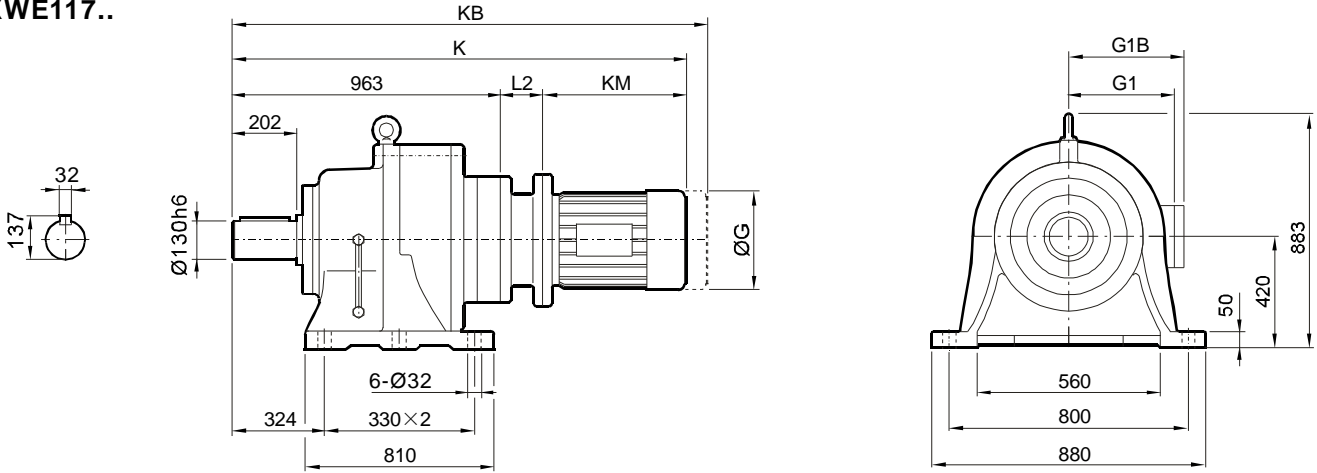

**XLE117..**

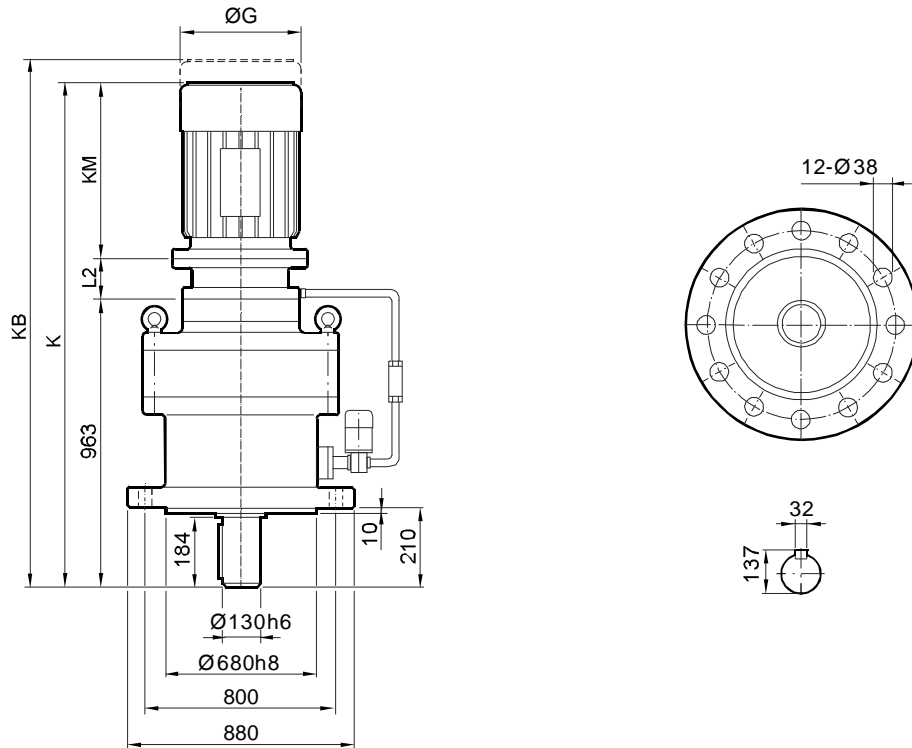

尺寸 Dimensions	电机规格 Motor frame										
	100	112	132S	132M	160M	160L					
<b>G</b>	215	240	275	275	330	330					
<b>G1</b>	175	185	205	205	255	255					
<b>G1B</b>	180	190	230	230	280	280					
<b>K</b>	1417	1421	1517	1517	1614	1669					
<b>KB</b>	1514	1521	1635	1635	1768	1823					
<b>KM</b>	341	345	412	412	472	527					
<b>L2</b>	113	113	142	142	179	179					

尺寸说明

以上尺寸为直联普通电机和制动电机尺寸；  
KB为制动电机尺寸,其余为普通电机尺寸；  
防爆电机，变频电机等须加过渡法兰，见171,172页。

**ATTENTION**

Dimensions of universal and brake motor shown in upon table,  
the others like explosion, inverter motor coupled by adaptor,  
the dimensions on page 171,172.



安装尺寸

Mounting Dimensions

联结法兰尺寸

Adapter dimensions

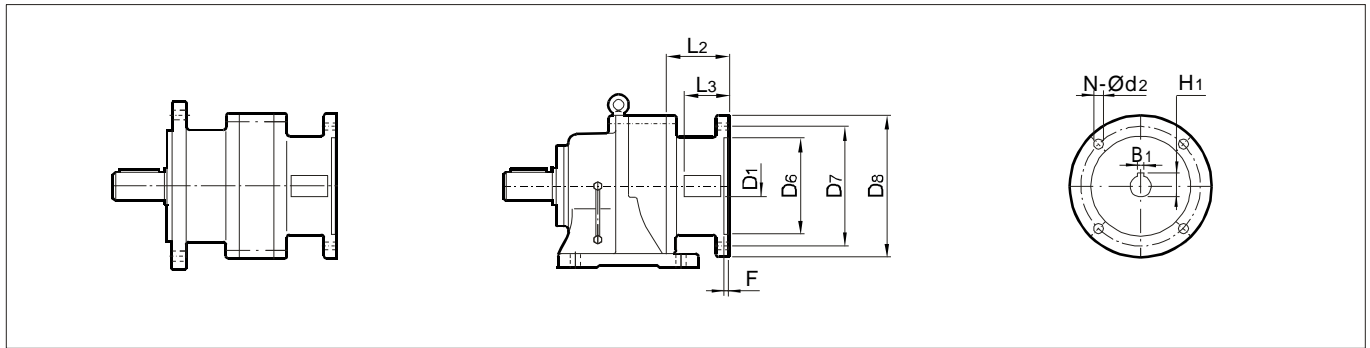

减速机型号 Gear unit size	法兰规格 Motor frame	D <sub>1</sub>	H <sub>1</sub>	B <sub>1</sub>	F	L <sub>2</sub>	L <sub>3</sub>	D <sub>6</sub>	D <sub>7</sub>	D <sub>8</sub>	N	d <sub>2</sub>
X..1	71B5	14F7	16.3	5	4	70	30	110H8	130	160	4	10
	80B5	19F7	21.8	6	4	77	40	130H8	165	200	4	12
X..1 B..12	71B5	14F7	16.3	5	4	70	30	110H8	130	160	4	10
	80B5	19F7	21.8	6	4	77	40	130H8	165	200	4	12
	90B5	24F7	27.3	8	4	95	50	130H8	165	200	4	12
X..3 B..15	71B5	14F7	16.3	5	4	70	30	110H8	130	160	4	10
	80B5	19F7	21.8	6	4	77	40	130H8	165	200	4	12
	90B5	24F7	27.3	8	4	95	50	130H8	165	200	4	12
	100B5	28F7	31.3	8	5	100	59	180H8	215	250	4	15
X..4 B..18	80B5	19F7	21.8	6	4	88	40	130H8	165	200	4	12
	90B5	24F7	27.3	8	4	95	49	130H8	165	200	4	12
	100B5	28F7	31.3	8	5	112	60	180H8	215	250	4	15
	112B5	28F7	31.3	8	5	112	60	180H8	215	250	4	15
	132B5	38F7	41.3	10	5	141	80	230H8	265	300	4	15
X..5 B..22	90B5	24F7	27.3	8	4	101	49	130H8	165	200	4	12
	100B5	28F7	31.3	8	5	117	60	180H8	215	250	4	15
	112B5	28F7	31.3	8	5	117	60	180H8	215	250	4	15
	132B5	38F7	41.3	10	5	140	80	230H8	265	300	4	15
	160B5	42F7	45.3	12	6	170	110	250G8	300	350	4	19
X..6 B..27	100B5	28F7	31.3	8	5	113	60	180H8	215	250	4	15
	112B5	28F7	31.3	8	5	113	60	180H8	215	250	4	15
	132B5	38F7	41.3	10	5	142	80	230H8	265	300	4	15
	160B5	42F7	45.3	12	6	179	110	250G8	300	350	4	19
X..7	112B5	28F7	31.3	8	5	113	60	180H8	215	250	4	15
	132B5	38F7	41.3	10	5	142	80	230H8	265	300	4	15
	160B5	42F7	45.3	12	6	179	110	250G8	300	350	4	19

注意!

- 1 选用底脚安装减速机时, 尺寸ØD8可能会超过底脚安装面, 请注意校核。
- 2 适配电机参照IEC B5法兰规格,其它未注尺寸请参考相关机型号。

Attention!

- 1 Dimension ØD8 may protrude past foot mounting surface if selecting foot-mounted type.
- 2 the motor flange perform IEC B5 type, dimensions is not indicated, please refer to correlative gear unit size



安装尺寸

Mounting Dimensions

联结法兰尺寸

Adapter dimensions

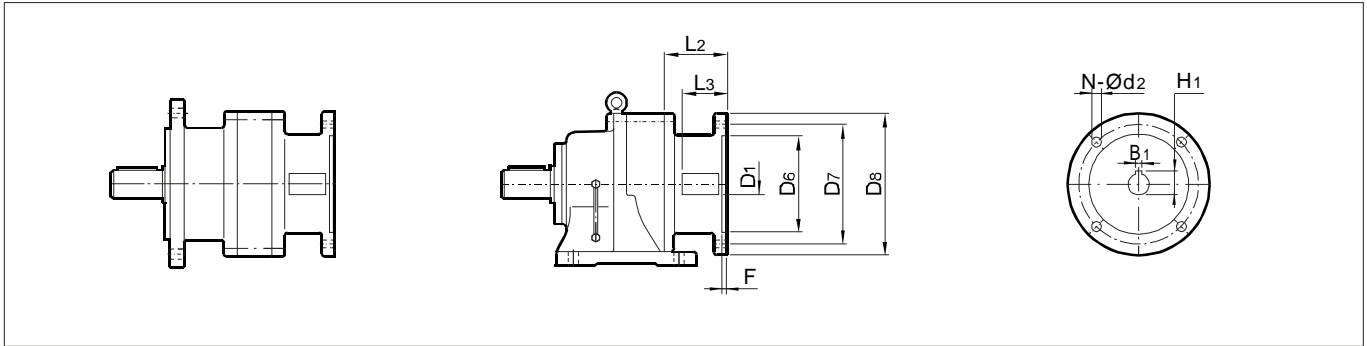

减速机型号 Gear unit size	法兰规格 Motor frame	D <sub>1</sub>	H <sub>1</sub>	B <sub>1</sub>	F	L <sub>2</sub>	L <sub>3</sub>	D <sub>6</sub>	D <sub>7</sub>	D <sub>8</sub>	N	d <sub>2</sub>
<b>X..8 B..33</b>	112B5	28F7	31.3	8	5	113	60	180H8	215	250	4	15
	132B5	38F7	41.3	10	5	142	80	230H8	265	300	4	15
	160B5	42F7	45.3	12	6	193	110	250G8	300	350	4	19
	180B5	48F7	48.8	14	6	193	110	250G8	300	350	4	19
	200B5	55E7	59.3	16	6	182	110	300G8	350	400	4	19
<b>X..9 B..39</b>	112B5	28F7	31.3	8	5	113	60	180H8	215	250	4	15
	132B5	38F7	41.3	10	5	142	80	230H8	265	300	4	15
	160B5	42F7	45.3	12	6	193	110	250G8	300	350	4	19
	180B5	48F7	48.8	14	6	193	110	250G8	300	350	4	19
	200B5	55E7	59.3	16	6	187	110	300G8	350	400	4	19
<b>X..10 B..45</b>	160B5	42F7	45.3	12	6	192	110	250G8	300	350	4	19
	160B5	48F7	48.8	14	6	192	110	250G8	300	350	4	19
	200B5	55E7	59.3	16	6	192	110	300G8	350	400	4	19
	225B5	60E7	64.4	18	6	192	140	350G8	400	450	8	19
	250B5	65E7	69.4	18	6	192	140	450G8	500	550	8	19
	280B5	75E7	79.9	20	6	192	140	450G8	500	550	8	19
<b>X..11 B..55</b>	160B5	42F7	45.3	12	6	192	110	250G8	300	350	4	19
	180B5	48F7	48.8	14	6	192	110	250G8	300	350	4	19
	200B5	55E7	59.3	16	6	192	110	300G8	350	400	4	19
	225B5	60E7	64.4	18	6	192	140	350G8	400	450	8	19
	250B5	65E7	69.4	18	6	192	140	450G8	500	550	8	19
	280B5	75E7	79.9	20	6	192	140	450G8	500	550	8	19

注意!

- 1 选用底脚安装减速机时, 尺寸ØD8可能会超过底脚安装面, 请注意校核。
- 2 适配电机参照IEC B5法兰规格,其它未注尺寸请参考相关机型号。

Attention!

- 1 Dimension ØD8 may protrude past foot mounting surface if selecting foot-mounted type.
- 2 the motor flange perform IEC B5 type, dimensions is not indicated, please refer to correlative gear unit size



安装尺寸

Mounting Dimensions

输入轴尺寸

With input shaft

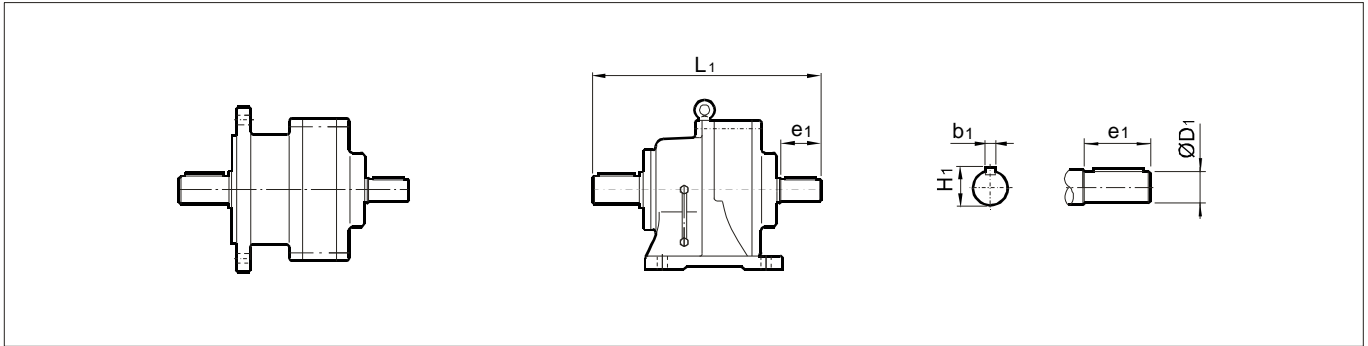

减速机型号 Gear unit size	L1	e1	b1	h1	D1
<b>X..1</b>	203	25	5	17	15h6
<b>X..2</b>	210	25	5	17	15h6
<b>X..3</b>	263	35	6	20.5	18h6
<b>X..4</b>	324	40	6	24.5	22h6
<b>X..5</b>	416	45	8	33	30h6
<b>X..6</b>	476	54	10	38	35h6
<b>X..7</b>	532	65	12	43	40h6
<b>X..8</b>	602	70	14	48.5	45h6
<b>X..9</b>	724	80	14	53.5	50h6
<b>X..10</b>	814	100	16	59	55h6
<b>X..11</b>	1065	120	20	74.5	70h6

减速机型号 Gear unit size	L1	e1	b1	h1	D1
<b>B..12</b>	215	25	5	17	30h6
<b>B..15</b>	282	25	6	20.5	35h6
<b>B..18</b>	352	40	6	24.5	45h6
<b>B..22</b>	422	45	8	33	55h6
<b>B..27</b>	490	54	10	38	70h6
<b>B..33</b>	629	70	14	48.5	90h6
<b>B..39</b>	730	80	14	53.5	100h6
<b>B..45</b>	783	100	16	59	110h6
<b>B..55</b>	966	120	20	74.5	130h6