

Desislava 20 Granulators Company

Bulgarian Chamber of Commerce and Industry

Registration Number: 1017244600 / 24.02.1992

www.desislava20granulators.com

VAT No.: BG040002183

Commercial Quotation 02-October-2007 GRANULATOR KOMPASS 800/1200 (CS)

Full protection at operation - Total stop before various accesses to the machine - Full automated control - Very strong frame - Strengthened design of the rotor and the cutting chamber - Easy change of the screen - **Hydraulic unit suitable for the opening of the screen cradle**: By this way the screen plate will be changed without the necessity to be move the Discharge system - Hydraulic unit for removing of the hopper - **Preventive Clutch between the shaft and the pulley for the rubber belts from the motor drive** - **Coated with Zinc before the painting** - Very low rate of the dust - Prolong term for a life of the knives before the changing for sharpening - Adjustable knives - A jig where the rotor knives can be pre-set outside of the machine so that you can change them quickly without adjusting them in the machine.

Purpose	DRY or WET GRINDING OF P.E.T. FLATTENED BOTTLES UP TO 1.2 – 2.0 METRIC TON PER HOUR AT SCREEN WITH DIAMETER OF THE HOLES 14 MM. MAX. SIZE OF THE BOTTLES: UP TO 10 LITRES		
Weight	12'500.00 kg		
Motors	132 kW / 1'500 rpm / 50 Hz / 400 V – Made in Germany 1.5 kW for the hydraulic unit for the opening of the machine 1.5 kW for the hydraulic unit of the screen cradle 3.0 kW for the Dehydrating unit		
Dehydrating unit (DU)	Ø 300 mm X L 3000 mm (made from Stainless steel)		
Rotor	Straight: 5 ROWS X 2 knives on each row Cutting Cylinder of the Rotor 800 mm X 1200 mm		
Knives	10 pcs. Fly knives X 600 mm 4 pcs. Bed knives X 600 mm (slant)		
Steel	X153CrMoV12 = D2 = 1.2379		
Screen holes	12 mm up to 16 mm		
Bearings	SKF		
Motor control	Will be manufactured with units from Telemecanique or Square - D		
Additional Parts	Knives set	10 fly knives + 4 bed knives	
Prices Ex Works	Screen	14 mm	
Prices Ex Works	Granulator	1 Piece	
	DU	1 Piece	
	DPS	1 Piece	
	FBC	1 Piece	
Terms of Payment	40 % with the order 60 % when the machine is ready for shipment (Before Shipment)		
Way of Payment	By Free Bank Remittance		
Manufacturing time	About 65 working days		
Validity of the Offer	30 working days		
Warranty	12 months from the date of delivery (the warranty doesn't include the cutting instruments, screen and the servicing). If it is needed to be sent spare parts the warranty terms cover the cost of the spare parts only Ex Works (the cost of the transport of the spare parts is not included in the warranty terms).		
Notes	§ If the grinding is WET, the machine should be working about 23-24 hours per day. If the working hours are 16 or less, the machine should be dried by hot air after the end of each working day. § CS = Carbon Steel.		

DISCHARGE PNEUMATIC SYSTEM (DPS) / (CS)

Purpose	The purpose of the DPS is to discharge the granulator and make the separation of the dust from the ground material.
Motor	7.5 kW / 1'500 rpm / 50 Hz / 400 V
Freight cost	The equipment will be sent together with the granulator
Terms of Payment	40 % with the order 60 % when the machine is ready for shipment (Before Shipment)
Way of Payment	By Free Bank Remittance
Manufacturing time	About 65 working days
Warranty	12 months from the date of delivery (the warranty doesn't include the servicing). If it is needed to be sent spare parts the warranty terms cover the cost of the spare parts only Ex Works. The cost of the transport of the spare parts is not included in the warranty terms.
Notes	§ The DPS contain: fan - working pipes - cyclone – stand for the cyclone - dust collection system and stand for this system. § CS = Carbon Steel

FEEDING BELT CONVEYOR (FBC) 1000 x 7000 / (CS)

a) Sizes:

- effective width – 1000 mm
- Height of the axis of the charge shaft – 1000 mm
- Height of the axis of the discharge shaft– 3100 mm
- distance between the shafts – 7000 mm

b) Leading:

- side of assembly – left in the direction of the belt motion
- Ø pushing drum – 320 mm
- Ø pulling drum – 320 mm
- el. motor – 2,2 kW/400 V/50 Hz/1500 rpm /4 pol.

c) Rubber belt:

- with increased performance for hardness of cutting and strokes
- thickness – 8 mm
- vulcanizing way of connection
- cleats – height 20 mm, width 2 x 350 mm, distance 500 mm

d) Legs:

- regulation +/- 150 mm
- 4 pieces. / 2 pieces with interlock/, Ø wheels 150 mm
- paint:
body blue - Blu Ral 5002
guard - yellow Ral 1003

Possibility for assembly of metal detector (Fe).
Possibility for assembly of metal separator (Fe).

Desislava 20 Granulators Company

If you require any further information, please contact us and we will be pleased to supply it.

We look forward to hearing from you,

Sincerely Yours,

Konstantin Tomov,
President of Desislava 20 Granulators Company

Tel./fax: +359 2 870 3295
Mobile: +359 896 872 859
Mobile: +359 886 010 842

E-mails:
info@desislava20granulators.com
support@desislava20granulators.com
desislava20@fastbg.net
ktomov@usa.com

Desislava 20 Granulators Company wishes you successful business!

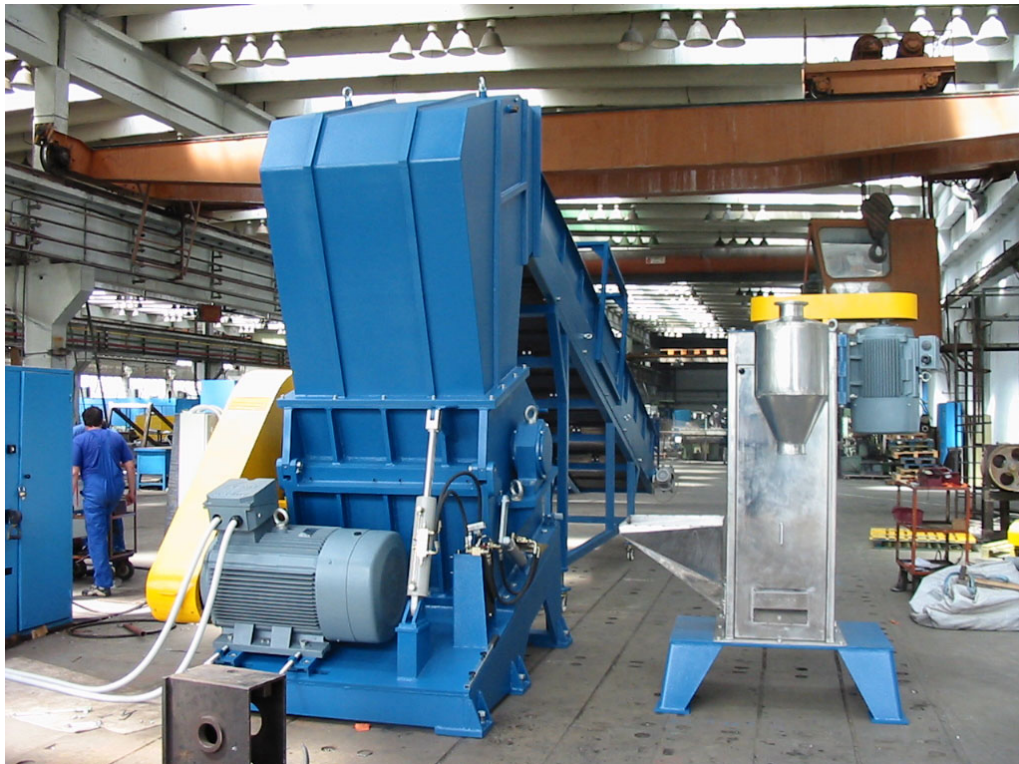

Desislava 20 Granulators Company



Desislava 20 Granulators Company

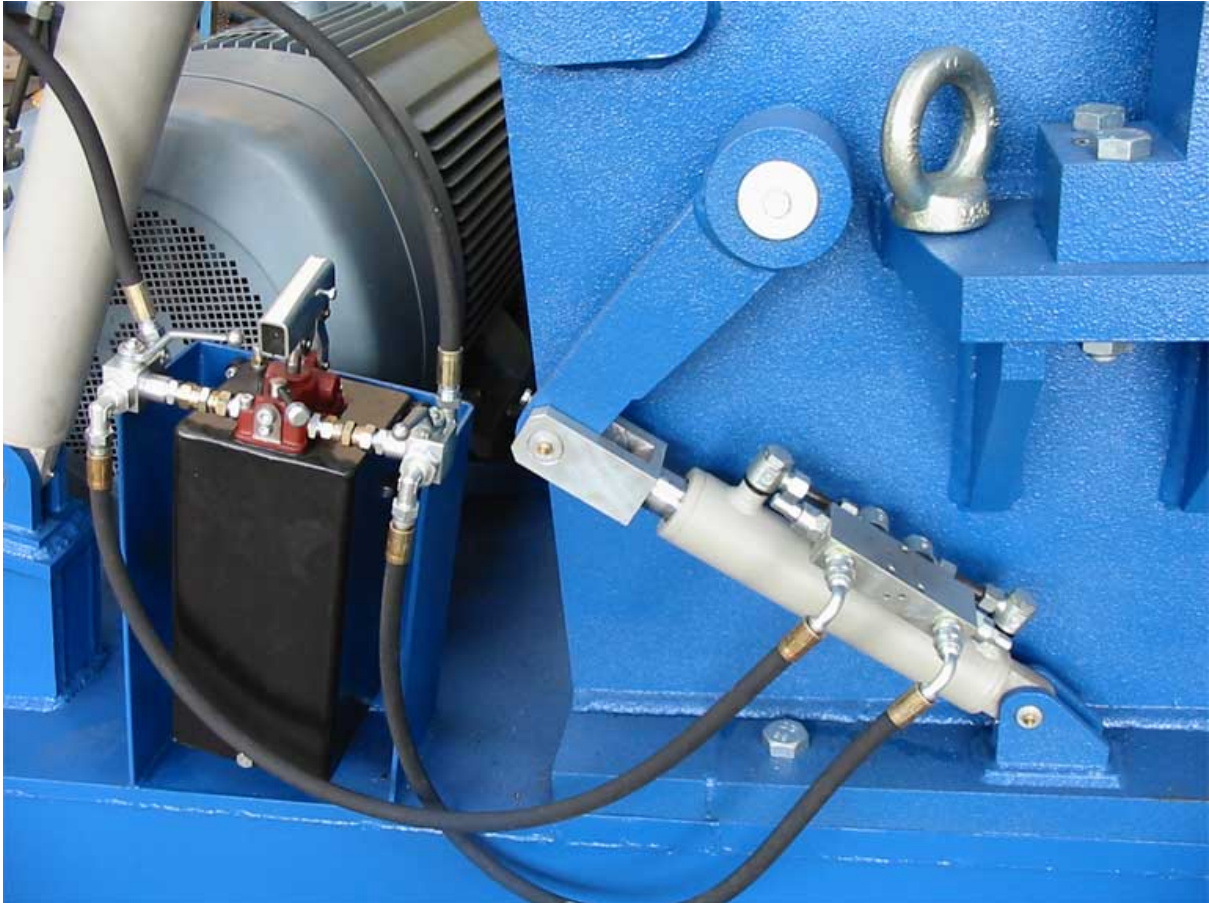

Desislava 20 Granulators Company

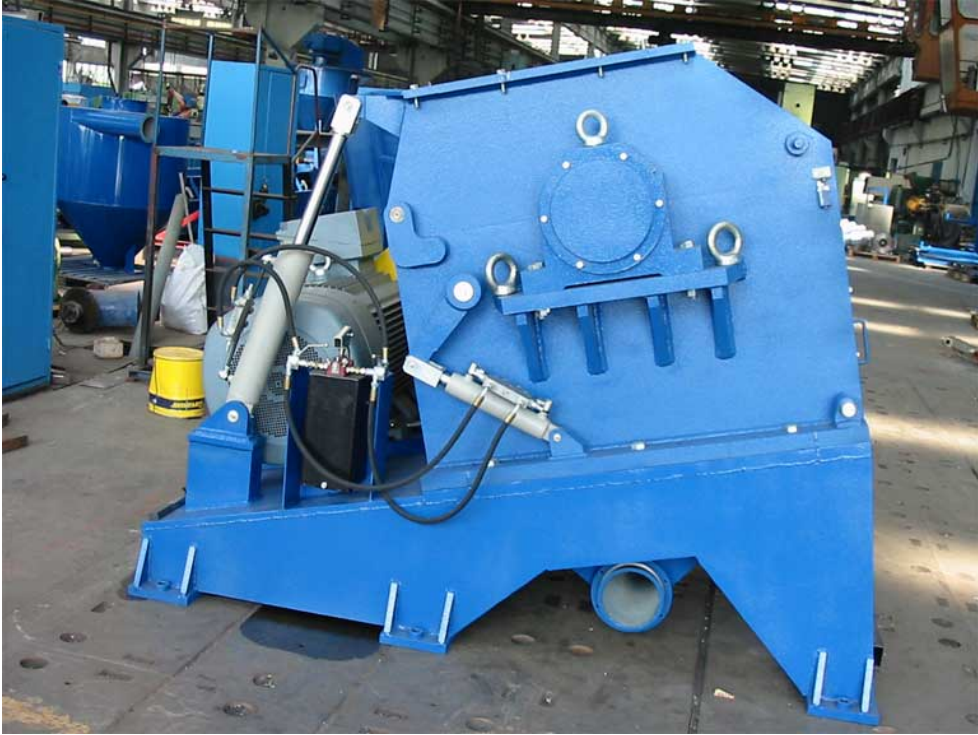

Desislava 20 Granulators Company



Desislava 20 Granulators Company



Granulator Kompass 800/1200 P.E.T. Design & DPS

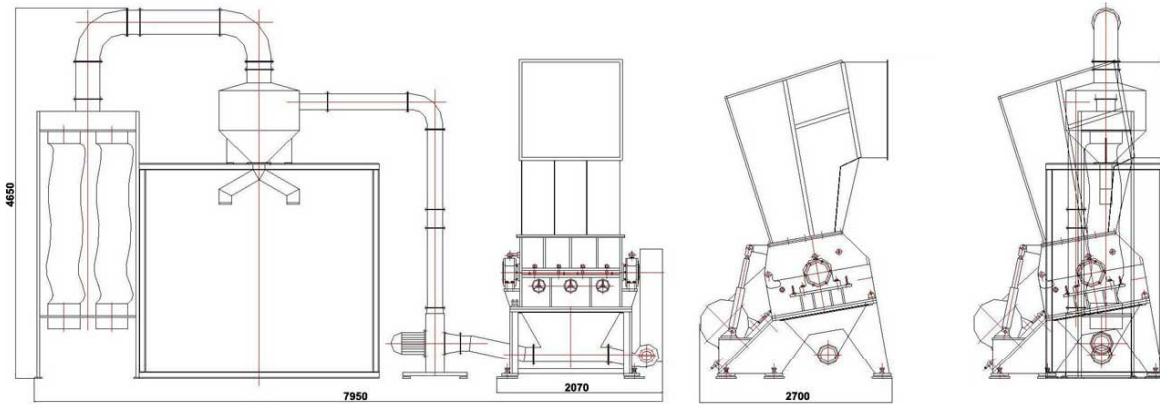

Granulator Kompass 800/1200 P.E.T. Design & Dehydrating screw

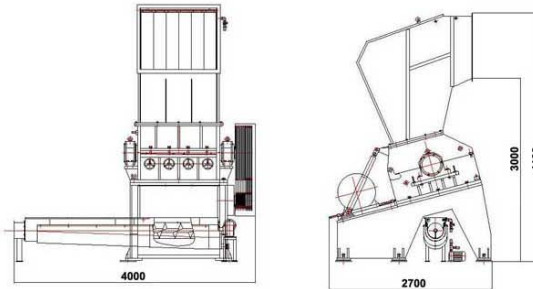

Desislava 20 Granulators Company

www.desislava20granulators.com

