

Features:

- Tank constructed of type 316L Stainless Steel with tolerance for high temperatures. Superior resistance to corrosion.
- High output heat exchanger for both the boiler back up heat exchanger and solar heat exchanger
- Environmentally safe CFC free water blown, extra thick foam insulation allows less than 1/2 degree F per hour heat loss, the best in the industry
- Outer shell constructed of silver finished durable plastic for rust and impact resistance
- Limited lifetime warranty - 7 year commercial and lifetime residential
- Easy to install and maintain
- Factory supplied Temperature and Pressure Relief Valve
- SRCC OG300 Certified Listing pending - applies to Federal Tax Credit when connected to a solar panel

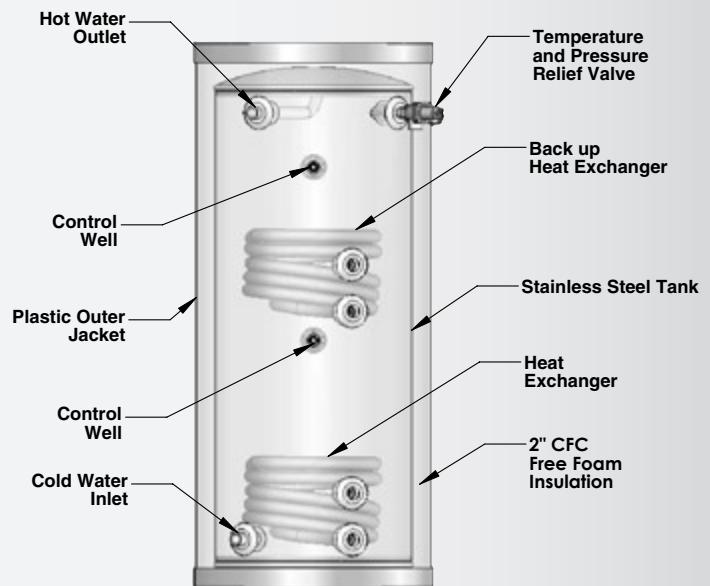
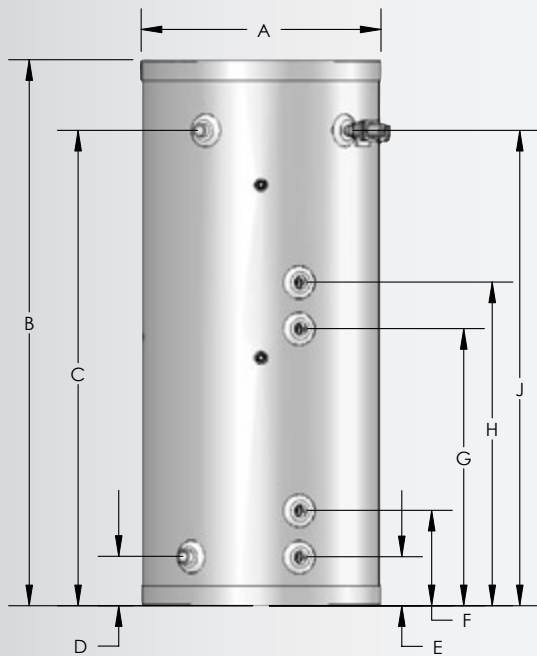

SUPERSTOR SOLAR WATER HEATER DIMENSIONS										
MODEL #	GAL.	DIMENSIONS								
		A	B	C	D	E	F	G	H	J
SSU-60SB	60	23"	52"	46"	5"	4-3/4"	9"	26-1/2"	31"	46"
SSU-80SB	80	23"	72"	64"	6"	5-1/2"	9"	35-3/4"	40-1/4"	64-3/4"
SSU-119SB	119	27"	74"	64"	6"	5-1/2"	9"	35-3/4"	40-1/4"	66"

SUPERSTOR SOLAR WATER HEATER SPECS				
MODEL #	GAL.	HEAT EXCHANGER OUTLET SIZE	INLET/OUTLET SIZE	SHIPPING WEIGHT (lbs)
SSU-60SB	60	1" NPT	1" NPT	120
SSU-80SB	80	1" NPT	1" NPT	151
SSU-119SB	119	1" NPT	1" NPT	220

SUPERSTOR SOLAR SB SERIES								
MODEL	HX VOLUME GALLONS		HEATED WATER VOLUME OF BACK UP	RECOVERY OF BACK UP IN MINUTES		BOILER OUTPUT FOR TEST RECOVERY	FIRST DRAW *	
	SOLAR	BOILER		65° RISE	90° RISE		65° RISE	90° RISE
SSU-60SB	1 GAL	1 GAL	35 GAL	74 MIN	102 MIN	104,000 BTU/HR	40 GAL	28 GAL
SSU-80SB	1 GAL	1 GAL	49 GAL	104 MIN	143 MIN	114,000 BTU/HR	60 GAL	40 GAL
SSU-119B	1 GAL	1 GAL	64 GAL	135 MIN	187 MIN	121,000 BTU/HR	90 GAL	60 GAL

* AMOUNT OF WATER DRAWN OUT OF STORAGE TANK WITHOUT ANY ENERGY INPUT

LP-196
06/22/07

Heat Transfer reserves the right to make product changes or updates without notice. Heat Transfer will not be held liable for typographical errors in literature. For questions, please consult the factory.



Solar Water Heater Specifications

This solar hot water storage tank shall be designed for production of domestic hot water from either a solar panel or a boiler. This tank shall be equipped with two heat exchangers to transfer heat from either heat source. The solar heat exchanger shall be located on the bottom section of the tank to heat the entire water volume of the storage tank. The boiler heat exchanger shall be located on the upper section of the storage tank providing back up heat if the solar panel is not providing enough heat to maintain the upper operating set point of the tank. This storage tank shall have a

capacity of _____ gallons.

This solar hot water storage tank will be equipped with a stainless steel control well to insert a sensor into the tank to control the operation of the solar heat exchanger. This storage tank will also have an additional control well located in the upper portion of the tank to insert a control, which will monitor and control the operation of the boiler back up heat source to maintain the desired hot water temperature.

This tank will be constructed of 316L Stainless

Steel. Both heat exchangers will be integral finned tube design constructed of 90/10 CU/Ni.

The outer tank shell shall be constructed of high density polyethylene plastic with 2" of CFC free polyurethane foam insulation.

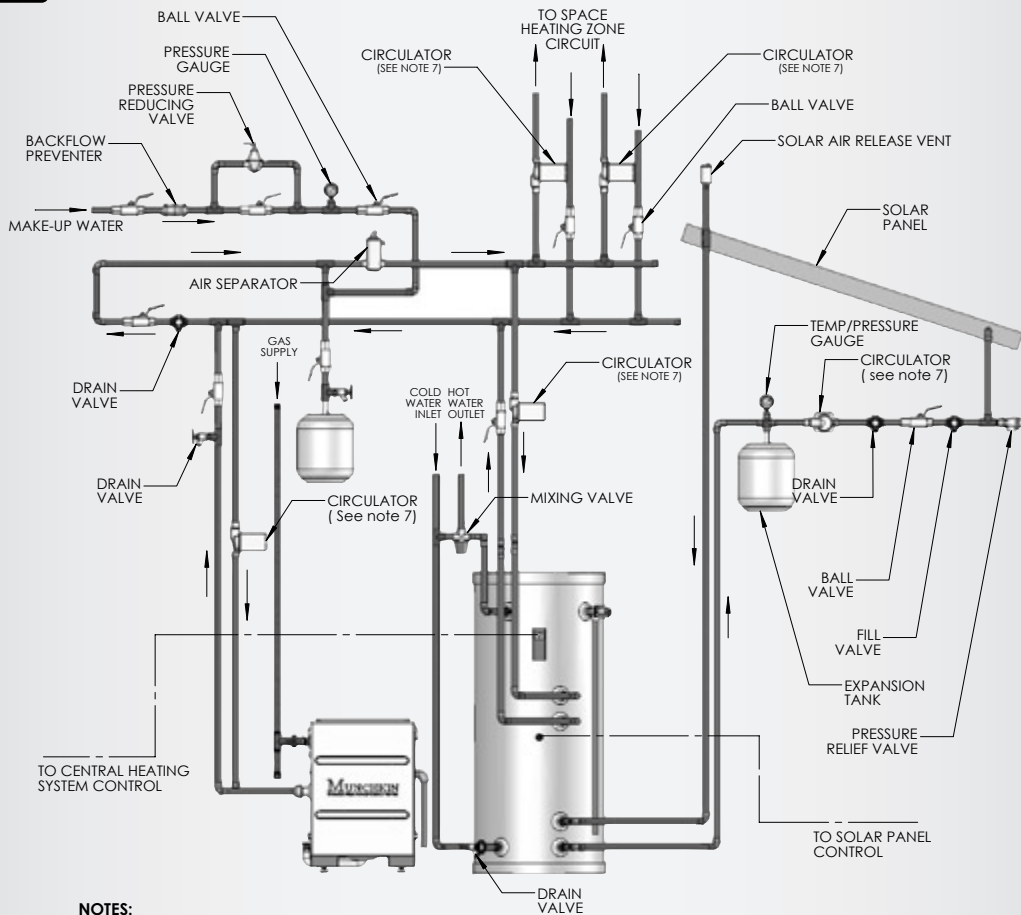

NOTES:

1. THIS DRAWING IS MEANT TO SHOW A SYSTEM PIPING CONCEPT ONLY. THE INSTALLER IS RESPONSIBLE FOR ALL EQUIPMENT AND DETAILING BY LOCAL CODES.
2. * ANTI-FREEZE, NON- POTABLE HEAT TRANSFER FLUID SHALL BE USED FOR THE SOLAR HEAT EXCHANGER CIRCUIT ONLY. NEVER INTRODUCE ANTI-FREEZE SOLUTION TO ANY OTHER CONNECTION OTHER THAN THE SOLAR HEAT EXCHANGER.
3. IF THERE IS A CHECK VALVE ON THE COLD WATER FEED LINE, A THERMAL EXPANSION TANK SUITABLE FOR POTABLE WATER MUST BE SIZED AND INSTALLED WITHIN THIS PIPING SYSTEM BETWEEN THE CHECK VALVE AND THE COLD WATER INLET OF THE SOLAR WATER HEATER. REFER TO FIG. 3-1
4. AN ANTI-SCALD MIXING VALVE IS RECOMMENDED IF THE DOMESTIC HOT WATER SETTING IS ABOVE 120F.
5. A MINIMUM OF 12 DIAMETERS OF STRAIGHT PIPE MUST BE INSTALLED UPSTREAM OF ALL CIRCULATORS.
6. **FOR ALL SE MODELS,** MAKE SURE TANK IS FULLY PURGED OF AIR BEFORE POWER IS TURNED ON TO THE ELECTRIC ELEMENT.
7. ALL CIRCULATORS SHOWN ABOVE SHOULD HAVE INTEGRAL FLOW CHECK.

LP-199-B Rev. 6/28/07