

Mig-29 Fulcrum

Dear customer,

congratulations on your purchase of our model of the famous **MiG-29 Fulcrum** fighter. Before commencing its building, please study the assembly instructions carefully and make sure you understand its sequence. If need be, contact the manufacturer or your dealer.

List of parts:

Name of part	Pcs.	Name of part	Pcs.
Fuselage of EPP	1	Elevator safety ring	2
Elevator control rods	2	Elevator axis (carbon 5x100 mm)	2
Wing of EPP	2	Elevator lever	2
Elevator of EPP	2	Instructions	1
Vertical tail of EPP	2	Self-adhesive sticker set	1
Engine nacelles	2	Wing spars (carbon 500x1mm)	2
Elevator axis bushing	4	Fuselage central panel of EPP	1
Engine bulkhead	1	Doubler of the fuselage motor section (Al 1,6x100)	2

You will need also the:

CA glue, CA glue activator, sharp (modelling) knife, 150 mm extension cable for servo???. To complete the model you will need: a receiver (MZK), servos (Wipont W-060), a controller (TMM-1210-3 or Jeti 12), an accumulator battery (3 LiPol cells of 640-1200 mAh), a motor (HCS-80/2E or similar of about 80 W output).

Description of the model:|

The model is completely made of EPP and has some carbon components. With its weight beginning at 250 grams it is an ideal model for flying in any suitable spot (e.g. a school playground or in the street). It is intended not only for experienced pilots, but also for the advanced modellers. To power it you may use a motor from our production, e.g. the HCS-80/2E, and three Lithium Polymer cells. Thanks to a well thought-out design the construction would take only about 90 minutes.

Building process:

Unless otherwise stated, all joints should be glued with the rapid CA glue. Start the building by assembling the engine nacelles (Fig. 1). Then glue the wings to the fuselage central part, and, using a sharp modelling knife, cut a 1-2 mm deep slit into the wing from both upper and lower side. Press the carbon rod into the slit and glue there from both sides, using the thin CA glue (Fig. 2). Work on a flat surface to ensure the complete assembly is not distorted. Insert the carbon tube through the location grooves and slide onto it the elevator lever, then the two securing rings from each side, respectively (Fig. 3). In the engine nacelles, cut the grooves for the elevator axis bushings. Move the securing rings to their extreme positions to eliminate any play in the carbon tube. Then carefully glue the rings, ensuring at the same time the freedom of movement of the carbon tube. Using the Fig. 4 as a guide, glue in place the bushings for the slab elevator. Pierce/drill a hole through a cube of EPP and slide it onto the control rod, to serve as the control rod guide. Glue the elevator servo in place (Fig. 5), setting the correct distance according to the position of the cut-out in the nacelle and install the elevator control rods (Fig. 6).

Check the neutral position of the servo and glue the respective halves of the elevator (Fig. 7). Ensure their planes are parallel and that they are at the same angle relative to the wings. Glue the engine nacelles to the fuselage (Fig. 8). Glue the fuselage main part (Fig. 9) and the vertical tail surfaces (Fig. 10). Using the Fig. 11 as a guide, glue the motor bulkhead and the rear fuselage aluminium doubler, screw-on the motor bearers (Fig. 12) and secure the motor.

Place the speed controller as per Fig. 13. Glue the engine nacelle upper part in place (Fig. 14). The location of the accumulator battery is shown of the Fig. 15. Using a hand-held soldering gun, cut a hole for the receiver into the fuselage (so that the servo cables would reach it). If the controller servo cable is long enough, we need not to use the extension servo cable. Connect cable extensions to the controller power cables, or cut the original cables shorter and splice them with new cables long as necessary. The model is now ready for balancing. By shifting the batteries, set the position of the centre of gravity to some 320 mm from the motor bulkhead. Then cut, using a soldering gun, an opening for the battery pack; the dimensions of the battery opening shall be some 2 to 3 mm less than the outer dimensions of the battery pack, so that the batteries would hold in place without any extra fixation.

Now the model is complete; for the first flight set the deflection of the controls to the half of their travel. As the model, thanks to the propeller torque, tends to roll to the left, set the trailing edge of the right half of the elevator some 4 mm up. The model has specific flight characteristics – thanks to its layout it can fly not only fast, but also very slow. Bear in mind that the propeller torque effect is much more pronounced during slow flight, especially after the launch, and the model rolls slightly to left.

This model is no toy – therefore avoid flying in crowded or such places where health or property not only of yourselves, but also of third persons could be jeopardised..

Many happy landings wishes FreeAir.

Pictures

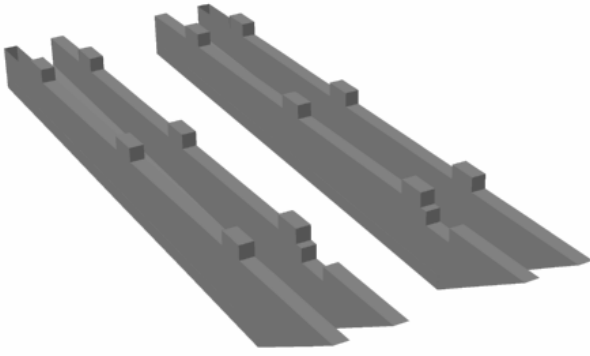

1

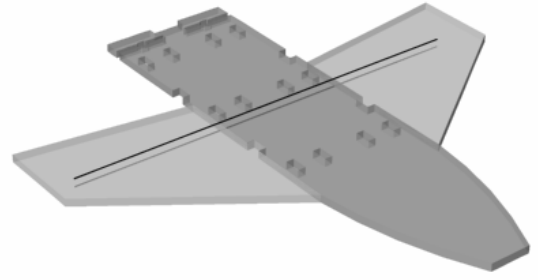

2

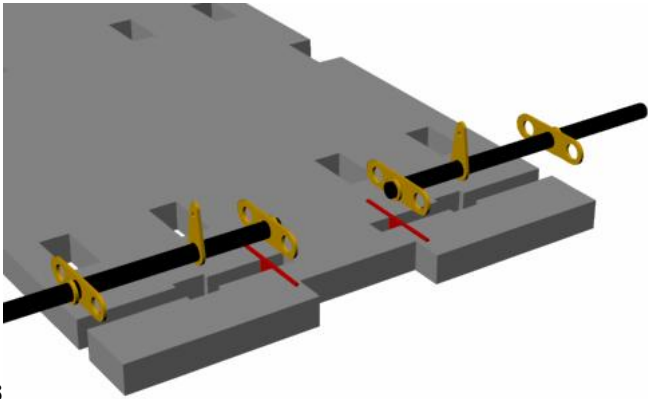

3

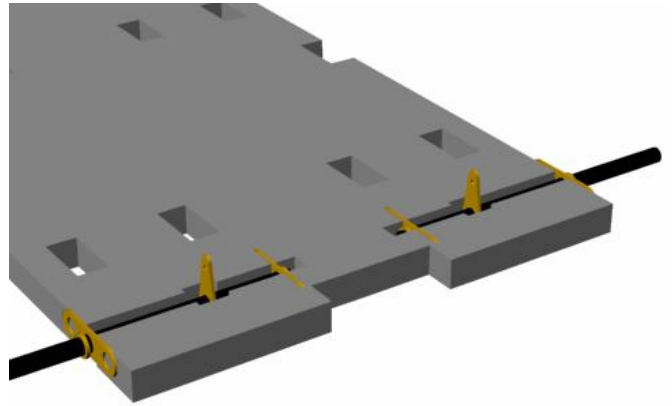

4

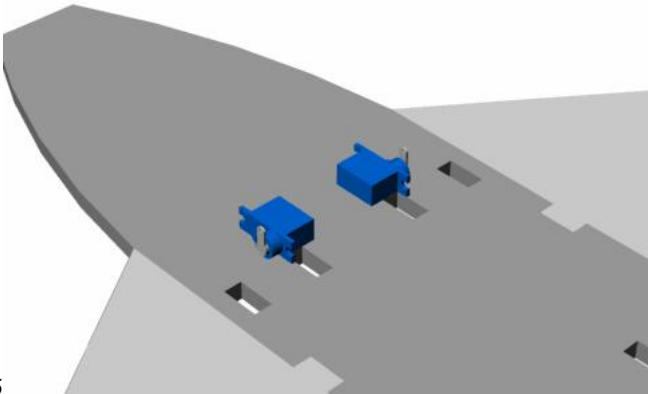

5

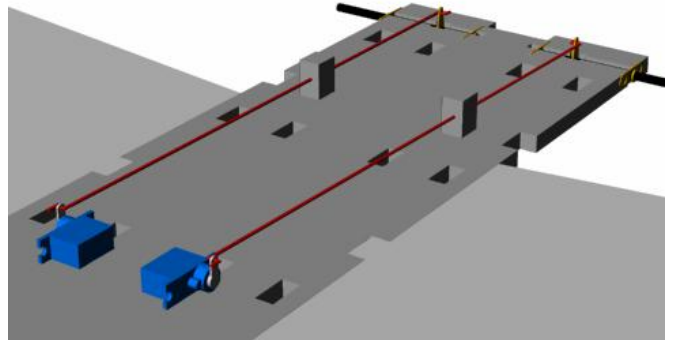

6

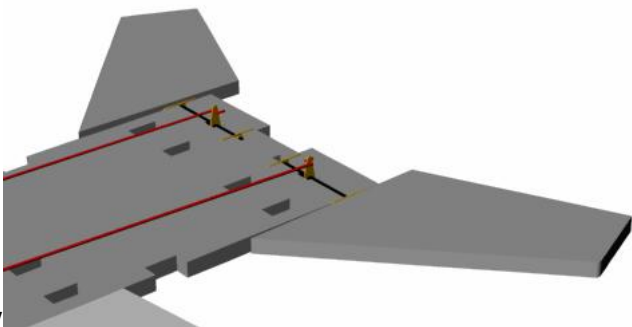

7

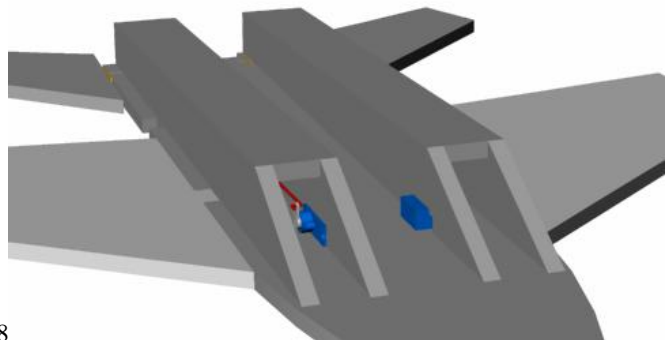

8

Pictures

