



TONNEAU INSTALLATION GUIDE

Warranty, Care & Maintenance

Model 4060 Toyota Tacoma Access/Quad Cab Long Bed (6 ft) 2005–Current **With Multi-Track System**



EASY AS 1-2-3! NORMAL INSTALLATION TIME



MINUTES

FORM # IG4060
Modified August 2006

(866) 900-8800 www.undercoverinfo.com

PRE-INSTALLATION NOTES

- 1** Be sure to use only cleaners, waxes, etc., which are labeled 'Safe for Plastics'. Make sure that chemicals or substances, which are not labeled 'safe for plastics', do not come in contact with your Undercover. Failure to do so could cause discoloration and/or structural damage to your Undercover and will void your warranty.
- 2** Paint rubbing of the truck is normally not a problem, but is always a possibility with any tonneau. To ensure less chance of possible paint rubbing of the truck, it is suggested to install a tailgate protector and adhere Cab Skin®, Scotch Cal®, or similar product to the truck bed. These products can provide added assurance against paint rubbing.
- 3** Undercover Tonneaus are designed from trucks that do not have a bed liner (spray-in bed liners pose no problem). Trucks that do have under-the-rail or over-the-rail bed liners will require some minor trimming of the bed liner to ensure proper placement of the mounting brackets. Due to the wide variety of bed liner manufacturers, the modifications will vary slightly between different brands. Any modifications must be made to the bed liner and NOT to the Undercover mounting hardware. Modifications to the mounting hardware will result in improper installation and will void your warranty.

INSTALLATION KIT CHECKLIST

- A: Hydraulic Struts
- B: J-Hooks & Wall Mounting Screws
- C: 6 UtiliTrac Flat Clamps
- D: Stainless Steel Bolts 5/16" x 1"
- E: Spiral Rings
- F: Stainless Steel Washers 5/16"
- G: Stainless Steel Lock Washers 5/16"
- H: Ball Stud Bracket
- I: Forward Mounting Brackets
- J: Rear Mounting Brackets

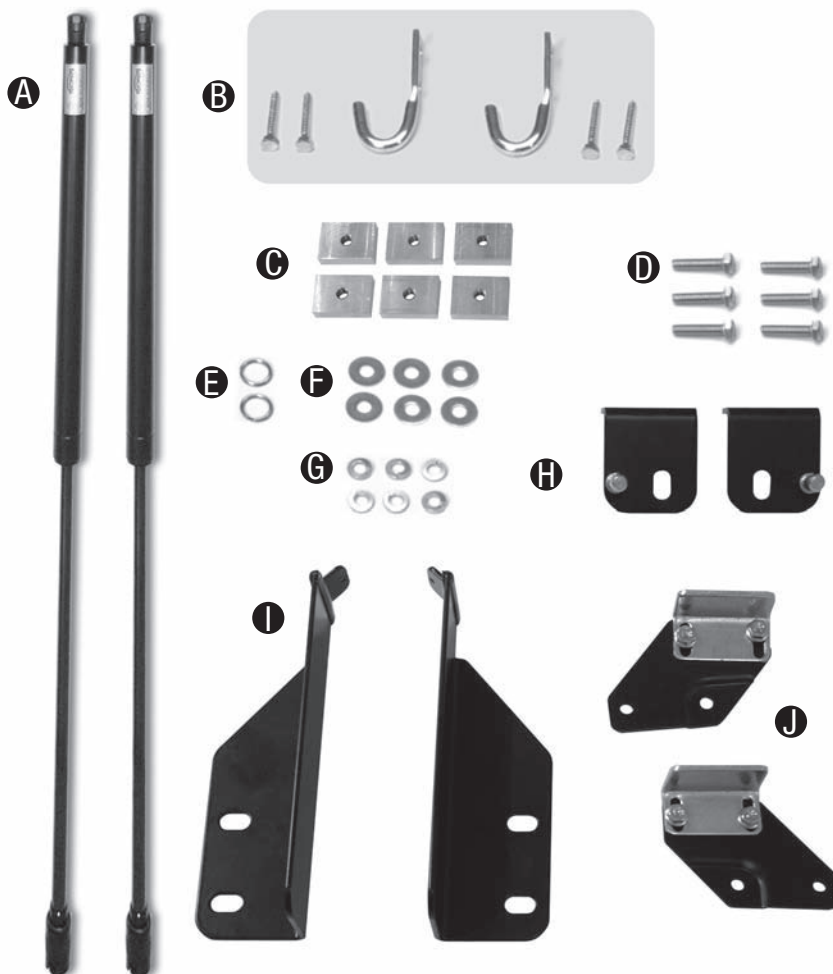
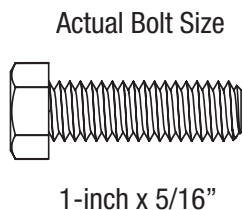

UNDERCOVER INSTALLATION TOOLS NEEDED

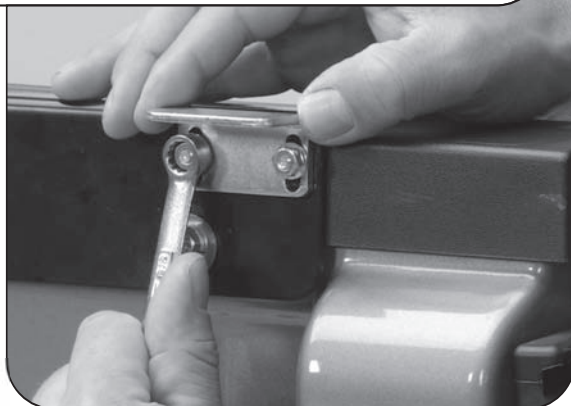

3/8"
WRENCH OR SOCKET



1/2"
WRENCH OR SOCKET



NORMAL INSTALLATION TIME



MINUTES

QUICK REMOVAL & REINSTALL REVIEW

Note: If your Tonneau has already been installed, skip to Page 9 for removal and reinstall instructions.

Off your truck and on your wall in less than one minute!

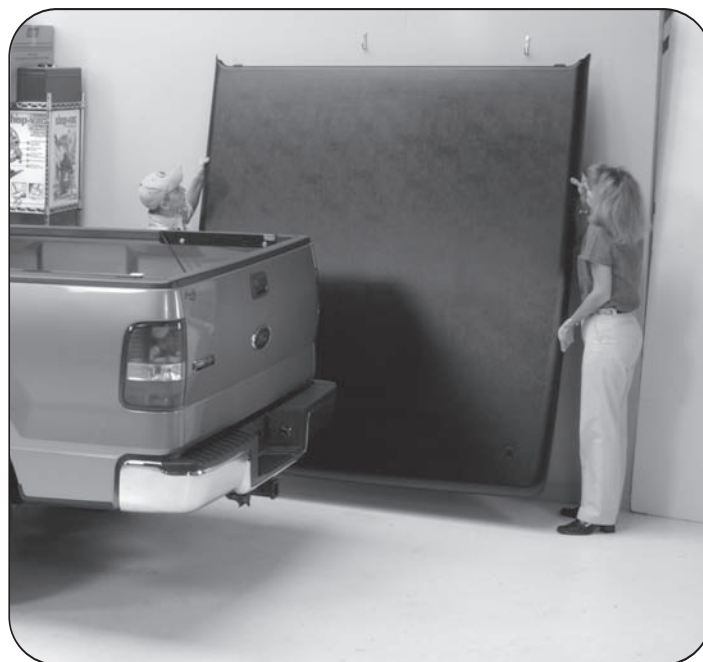

EASY AS 1-2-3

UNDERCOVER INSTALLATION INSTRUCTIONS



FACT:
Undercover is the lightest hardshell tonneau in the industry. Only 58-pounds for full size trucks.



NOTE: Before you can begin installing the mounting system, you must first remove the Multi-Track cleats. The MultiTrack cleats cannot be used while the cover is mounted. Cleats can only be used while the cover is uninstalled **Page 4, Picture A.**



Insert 5/16 Lock Washer & 5/16" Washer onto 1" bolt and thread through two holes on front bracket **Page 4, Figure 1, Picture B.**



Slightly screw-on two Multi-Track Clamps before mounting onto to Multi-Track System **Page 4, Figure 1, offset picture B.** Slide bracket forward to front of bulkhead **Page 4, Figure 2, Picture C.**



Before tightening two Multi-Track Clamps, you must first set the bracket into its proper starting position. (Remember, this position can change based on the square of the bed. See adjustment instructions in Step 3). To set the proper position, you must first measure 7 1/2" from OUTSIDE the bulkhead to the end of the bracket **Page 4, Figure 3, Picture D.**



Tighten down two Multi-Track Clamps using a 1/2" wrench or socket while holding bracket down tightly against the truckbed, so as to not let the front bracket slide out of position **Page 4, offset Picture D.**



Repeat steps A –thru– D for opposite side.



WARNING! Bolts must be tightened to the correct torque (20 in. lbs) to prevent any movement of the bracket on the truck bed. Bolts must be re-checked for tightness periodically. Failure to do so could cause serious damage to both the truck and/or your Undercover.

UNDERCOVER INSTALLATION INSTRUCTIONS



Figure 1

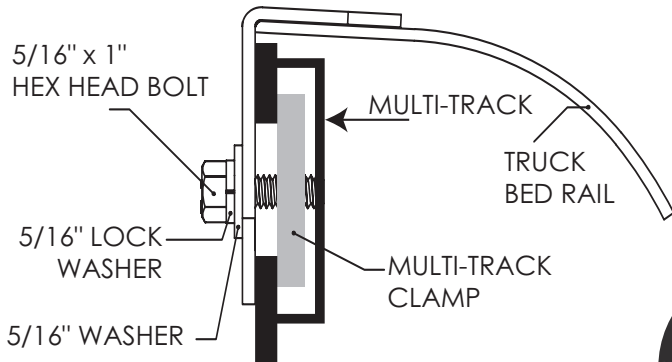

Figure 2

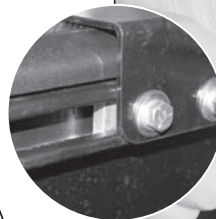
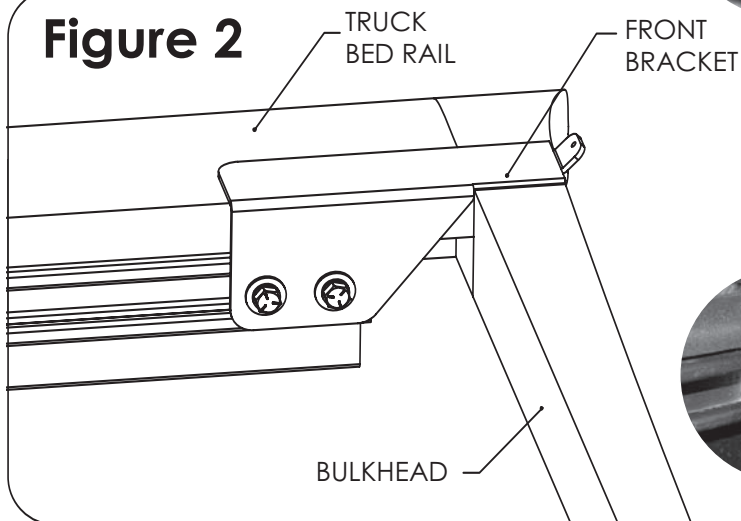
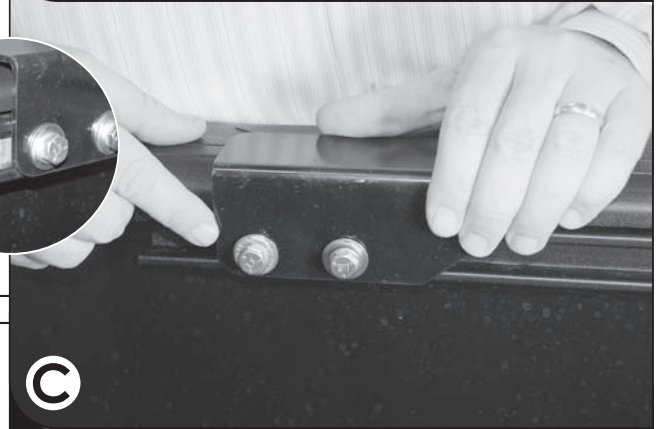
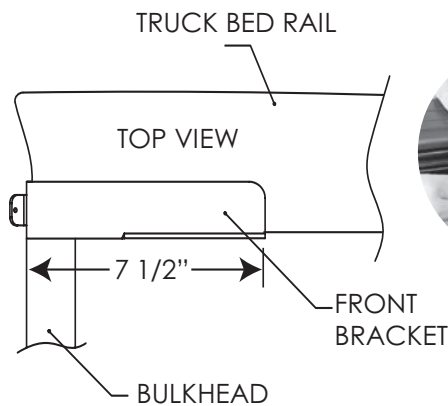

Figure 3



EASY AS 1-2-3

UNDERCOVER INSTALLATION INSTRUCTIONS



FACT:
Undercover's
ABS-Composite
material makes
it the strongest
and most
durable tonneau
on the market.



A For the Multi-Track system there are 2 brackets per side, for the rear mounting system. A Strut-Mounting bracket and a Rear-Mounting bracket. You must first install the Strut-Mounting Bracket before installing the final Rear-Mounting Bracket. Insert a 5/16" lock washer and a 5/16" washer on to a 5/16"x 1" bolt and thread through the single hole in the Strut-Mounting Bracket. Slightly screw on the Multi-Track Flat Clamp before mounting on to the Multi-Track system **Page 6, Fig. 4, offset Picture A.**

B Slide the Strut Mounting Bracket onto the Multi-Track System **Page 6, Picture A.** You will have to slide the Strut-Mounting Bracket into the proper position **Page 6, Figure 5, Picture B.** From outside the bulk head of the truck bed measure 51-inches to the center of the ball stud. Tighten down the bolt using a 1/2" wrench or socket.

C You are ready now to install the final bracket for the Rear-Mounting System. It is very important to realize that the Rear-Mounting Bracket uses 2 bolts already provided by Toyota that are used to hold in place the rear light well portion of the bed **Page 6, Picture C.** Thread the bolts through the two holes on the Rear-Mounting Bracket and tighten the two bolts into the light well portion of the bed. **Page 6, Figure 6, Picture D.**

D Repeat steps A –thru– C for the opposite side.



NOTE: Remember that the two bolts needed to install the rear bracket are the same bolts already used by Toyota to hold the rear light well portion of the bed.

UNDERCOVER INSTALLATION INSTRUCTIONS

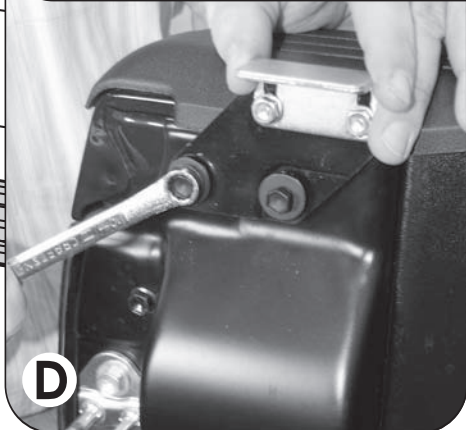
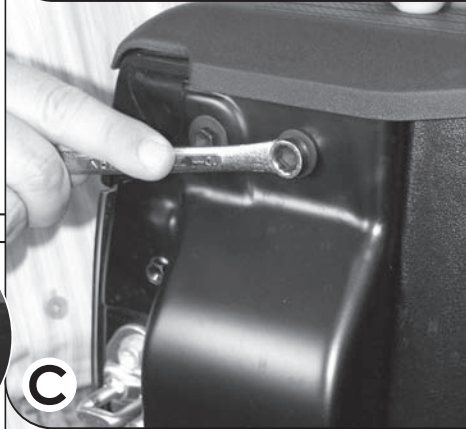
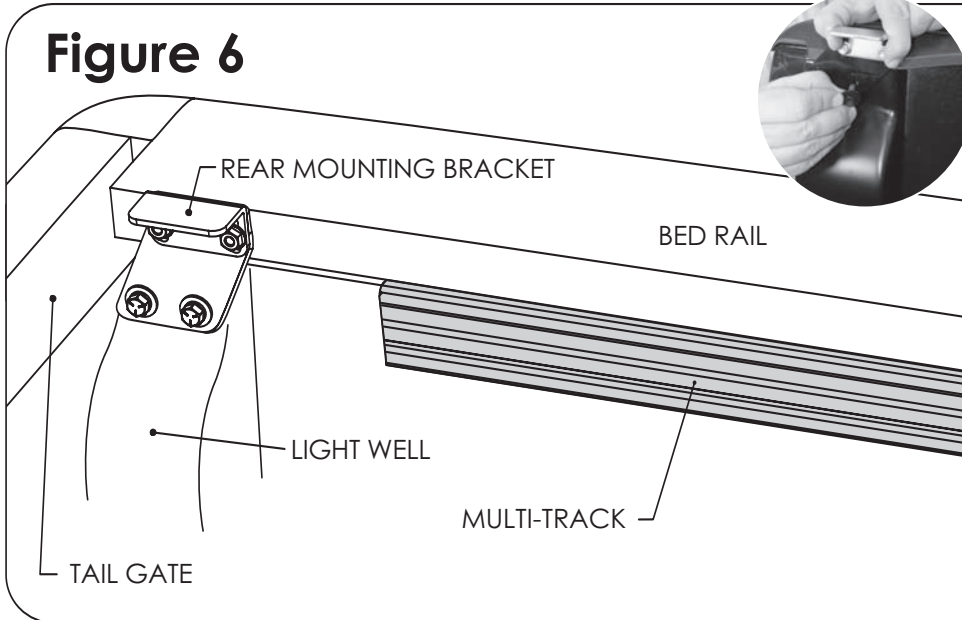
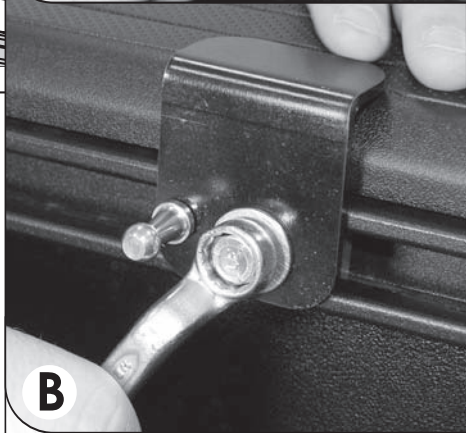
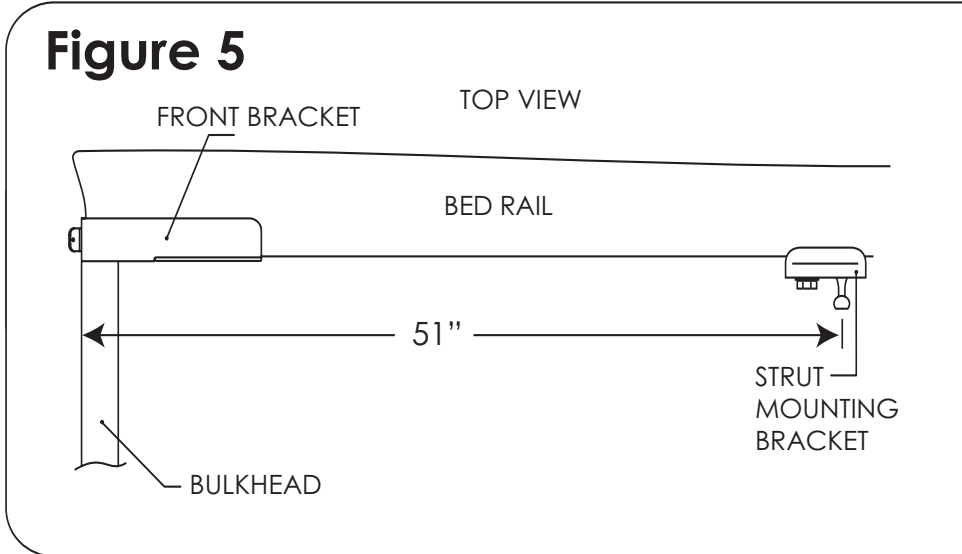
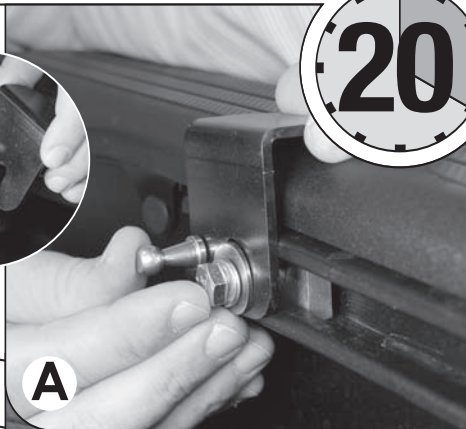
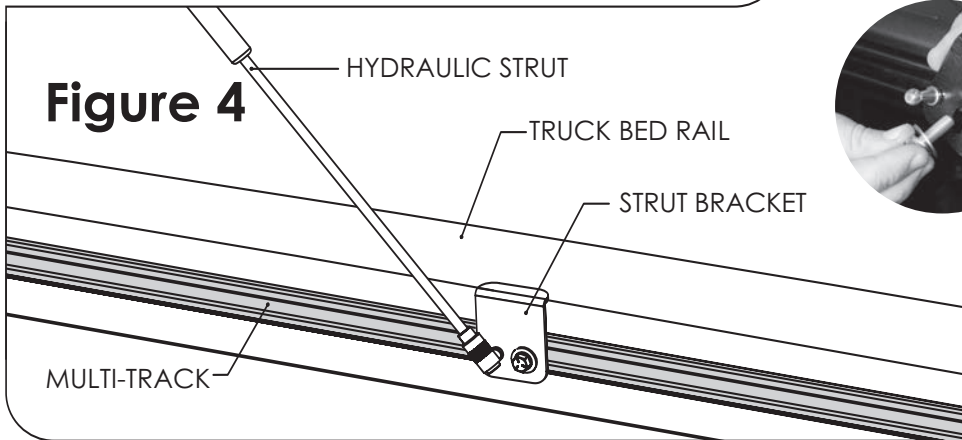

EASY AS 1-2-3

UNDERCOVER INSTALLATION INSTRUCTIONS



FACT:

In less than one minute, you can both take on and off the Undercover tonneau. Fastest removal system in the industry.

- A** Install hydraulic struts making sure LARGE end of strut is attached to the tonneau, and SMALL or rod end is attached to the ball stud on rear center strut bracket **Page 8, Figure 7, Picture A.**
- B** Be sure that the front flap seal hangs over the bulkhead of the truck and is not rolled under the tonneau after installation. If flap seal is rolled under the tonneau, open the tonneau and from the inside use a yardstick or something similar to push the flap seal out from under the tonneau and over the bulkhead **Page 8, Figure 8, Picture B.**
- C** Close tonneau and check length on the truck. There should be 1/8" -to- 3/8" gap between the tailgate and the tonneau. If this is not correct, adjust by moving front brackets forward or back to achieve correct length. Front brackets may also have to be adjusted independently to "square-up" tonneau on some truck beds.
- D** Adjust lock strikes **Page 8, Picture C.** When adjusted properly you should be able to turn the key to the locked position without having to push down on the tonneau. There should be a very slight amount of play between the lock cam and lock strike. A good rule of thumb is to adjust the lock to have approximately 1/8" gap between the cam and lock strike with the truck tailgate down. This usually gives you the proper adjustment after the tailgate is shut **Page 8, Figure 9, Picture D.**



WARNING: It is very important to be able to turn the key without any resistance. Do not try to force the lock cam to turn if you encounter resistance. This could result in a broken key or broken lock. Adjustment may be necessary to the lock strike plate to achieve a smooth turn without any resistance.

UNDERCOVER INSTALLATION INSTRUCTIONS

30

Figure 7

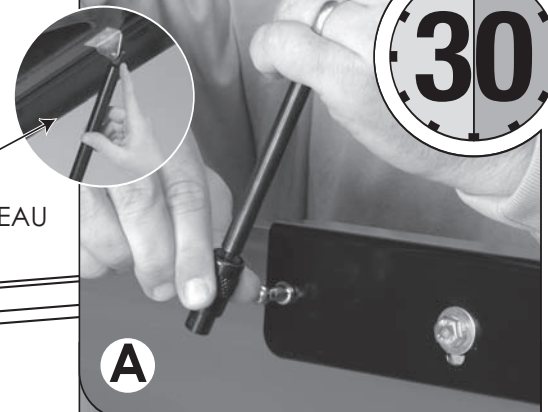
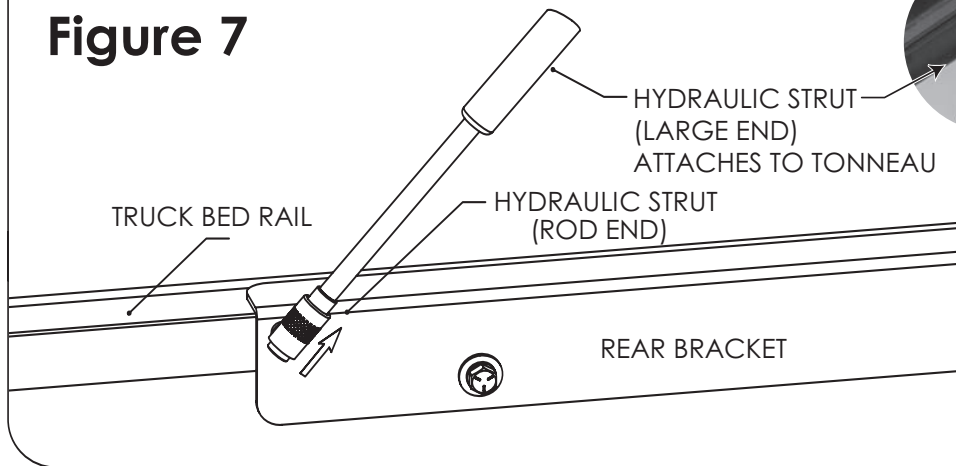

Figure 8

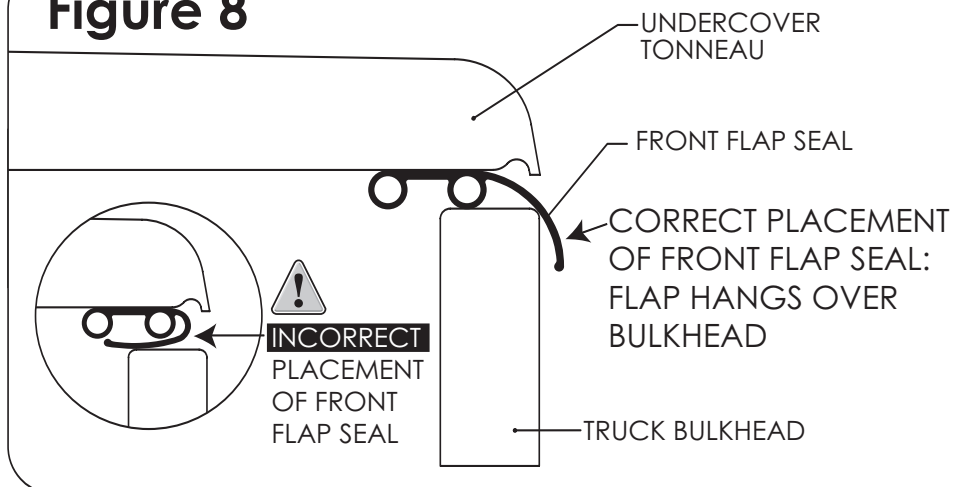
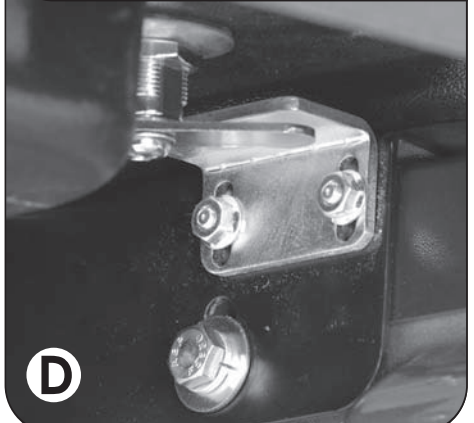
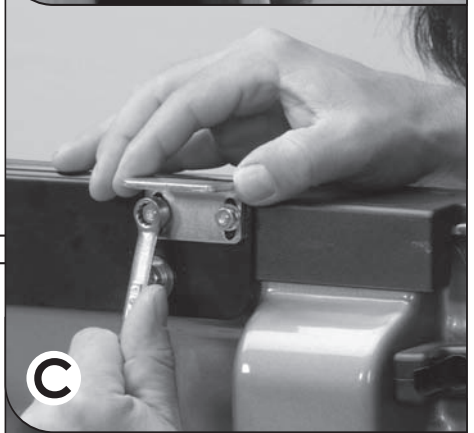
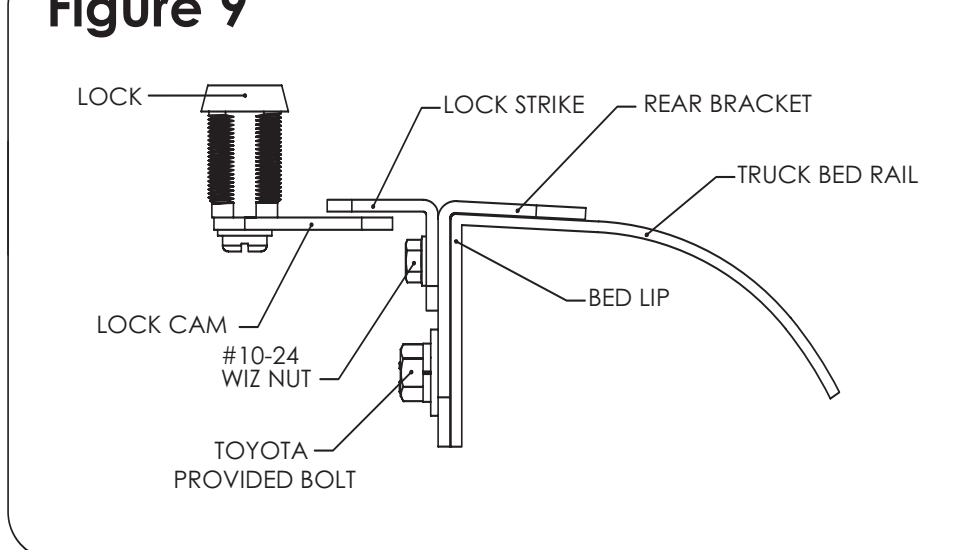

Figure 9



Congratulations! Your 30-minute installation job is now complete. Now, in less than one minute, you will be able to put on and take off your tonneau cover.

UNDERCOVER REMOVAL & REINSTALLATION INSTRUCTIONS

1 Minute Removal

Step 1 Release strut off of ball stud. Holding tonneau up with one hand, place loose end of strut on storage clip. Repeat for the other side **Picture A & B**.

Step 2 With cover closed, remove spiral rings at the front of the tonneau. BE SURE TO HAVE STEP 1 COMPLETED FIRST **Picture C**.

Step 3 Now carefully remove the tonneau off of the truck bed **Picture G**.

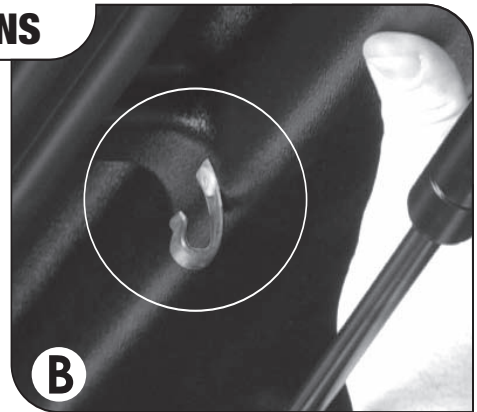

1 Minute Re-Install

Step 1 Place tonneau on the truck bed positioning hinges over front bracket tangs **Picture D**.

Step 2 Install spiral rings on tangs to secure cover **Picture C**. Open tonneau and attach strut to ball stud **Picture A & B**.

Step 3 Be sure that the front flap seal is hanging over the bulkhead, not rolled under the tonneau after installation **Picture E & F**.

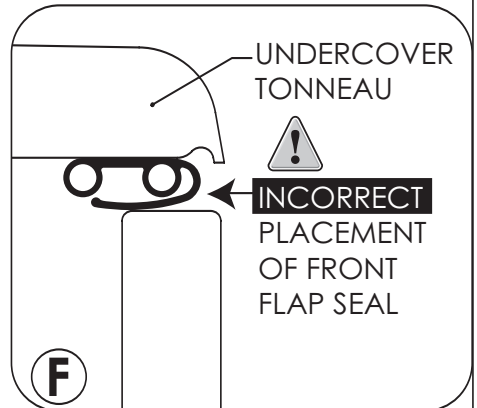

UNDERCOVER WALL HANGING INSTRUCTIONS

Step 1 Prior to removing the tonneau, mount the two J-Hooks provided on the garage wall. The hooks must have a minimum height from the floor of 70", and be 32" on center horizontally apart **Picture A & B**.

Step 2 Remove your tonneau from the truck bed according to instructions on page 9, 1-Minute Removal.

Step 3 Hang tonneau vertically on the wall-mounted J-Hooks, with the underside against the wall inserting J-Hooks into the holes provided in **Picture C**.

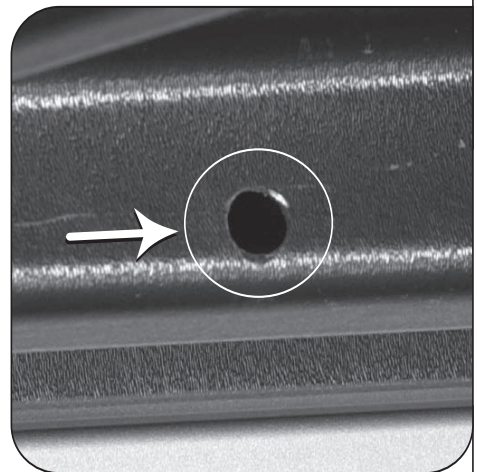
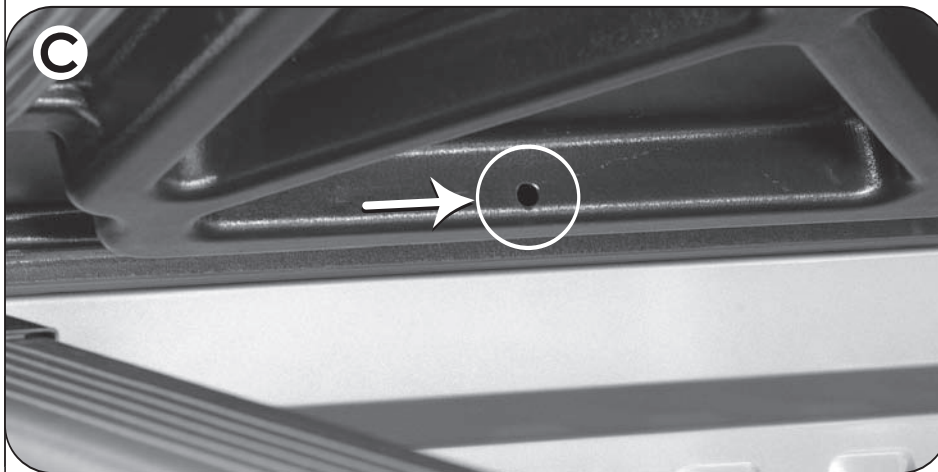
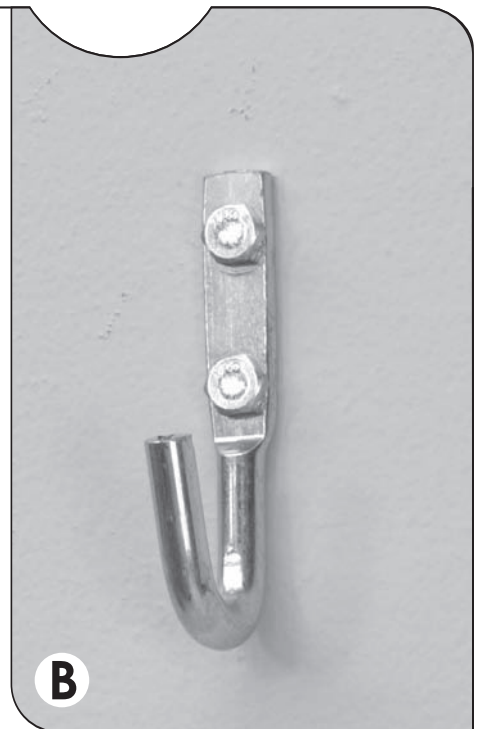
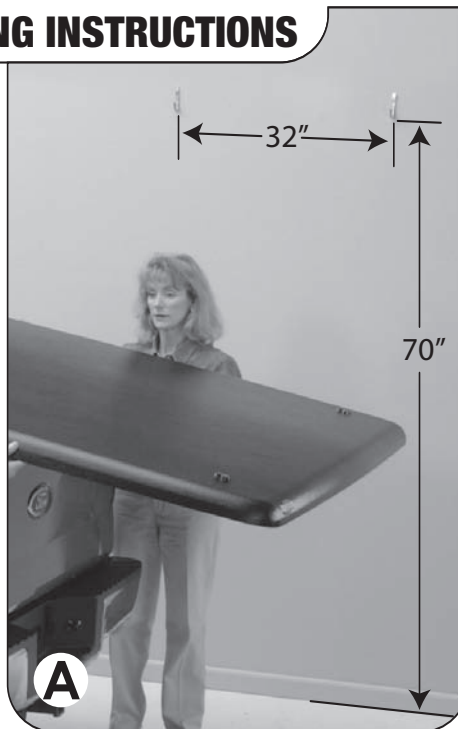



TONNEAU INSTALLATION GUIDE

Model 4060 Toyota Tacoma Access/Quad Cab Long Bed (6 ft) 2005–Current w/Multi-Track System

UNDERCOVER SERIAL NUMBER LOCATION

The Serial Number sticker is located on the left rear of the tonneau, just under the back overhang.

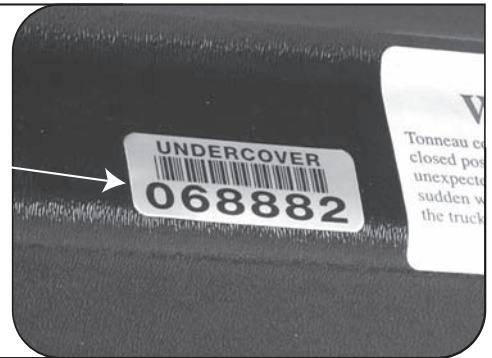
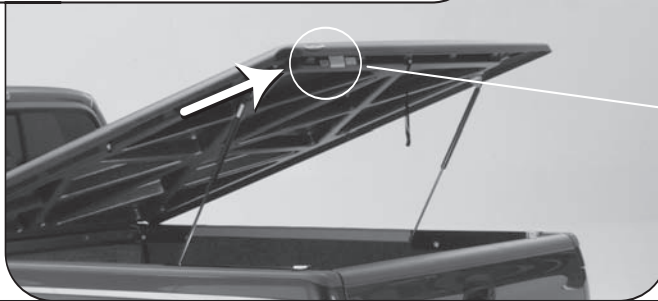

THANK YOU!

Congratulations! You've just installed the fastest-selling, highest-quality tonneau in the industry. Thank you very much for your purchase of UnderCover!

Steve Brallier

**Steve Brallier
President
E.D. Industries/UnderCover**



E.D. Industries/UnderCover
P.O. Box 620
Rogersville, MO 65742
(417) 753-8000
(866) 900-8800
www.undercoverinfo.com
sales@undercoverinfo.com



© 2006 E.D. Industries, Inc.
All rights reserved.