



www.undercoverinfo.com

TONNEAU INSTALLATION GUIDE

Warranty, Care & Maintenance

Model 2110 Ford Sport Trac 2007



EASY AS 1-2-3!

NORMAL INSTALLATION TIME

30

MINUTES

FORM # IG2110

Modified January 2007

For Warranty Issues, Contact Undercover Directly
(866) 900-8800 www.undercoverinfo.com

PRE-INSTALLATION NOTES

- 1** Be sure to use only cleaners, waxes, etc., which are labeled 'Safe for Plastics'. Make sure that chemicals or substances, which are not labeled 'safe for plastics', do not come in contact with your Undercover. Failure to do so could cause discoloration and/or structural damage to your Undercover and will void your warranty.
- 2** Paint rubbing of the truck is normally not a problem, but is always a possibility with any tonneau. To ensure less chance of possible paint rubbing of the truck, it is suggested to install a tailgate protector and adhere Cab Skin®, Scotch Cal®, or similar product to the truck bed. These products can provide added assurance against paint rubbing.
- 3** Undercover Tonneaus are designed from trucks that do not have a bed liner (spray-in bed liners pose no problem). Trucks that do have under-the-rail or over-the-rail bed liners will require some minor trimming of the bed liner to ensure proper placement of the mounting brackets. Due to the wide variety of bed liner manufacturers, the modifications will vary slightly between different brands. Any modifications must be made to the bed liner and NOT to the Undercover mounting hardware. Modifications to the mounting hardware will result in improper installation and will void your warranty.

INSTALLATION KIT CHECKLIST

- A: Hydraulic Struts
- B: Front Mounting Brackets
(mounted to Bedrail)
- C: 4-Bar Hinge with Twist Knobs
(mounted to the Cover)
- D: Ball Studs
- E: J-Hook Wood Screws
- F: Rear Mounting Bracket
- G: Wall-Mounting J-Hooks
- H: 6mm Bolts
- I: Lock Washers
- J: Washers



UNDERCOVER INSTALLATION TOOLS NEEDED



10mm WRENCH OR SOCKET, TORX BIT T-30, NEEDLE-NOSE PLIERS, 1/2-INCH WRENCH.

NORMAL INSTALLATION TIME



MINUTES

QUICK REMOVAL & REINSTALL REVIEW

Note: If your Tonneau has already been installed, skip to Page 9 for removal and reinstall instructions.

Off your truck and on your wall in less than one minute!



EASY AS 1-2-3

UNDERCOVER INSTALLATION INSTRUCTIONS



FACT:
Undercover is the lightest hardshell tonneau in the industry. Only 58-pounds for full size trucks.



A Installing your Ford Sport Trac hardware is very simple and easy to do. The Sport Trac comes with the mounting holes already in place. Our hardware mounts right to the existing holes. **Page 4, Picture A** is what the final rear bracket will look like once it is installed.

B Remove the plastic plugs with a pair of needle-nose pliers. Save these in a plastic bag for future use if you ever remove the bracket system. **Page 4, Picture B.**

C Take your rear-mounting bracket and thread your 6mm bolts and washers through the bracket into the preset threads. It will take two bolts and a set of washers. See **Page 4 Picture C.** Once you have hand-tightened down the bolts use a 10mm wrench to firmly secure the bolts to the bed. **BE SURE AND DO NOT OVER TIGHTEN, YOU COULD SHEAR-OFF THE BOLT HEAD.** See **Page 4 Picture D.**

D To adjust this bracket so that the lock cams will slide under the lock plate, there are two slots that will allow the rear bracket to slide up or down. The best position to start with is the bracket in its highest position. If necessary you can adjust after you mount the cover to the bed. See **Page 4, Picture E.**

E Repeat steps A through D for the other side.



WARNING! Be sure and do not over-tighten the rear-mounting bolts. Doing so can shear-off the bolt heads, creating a difficult procedure to remove the remaining thread.

UNDERCOVER INSTALLATION INSTRUCTIONS



A



B



C

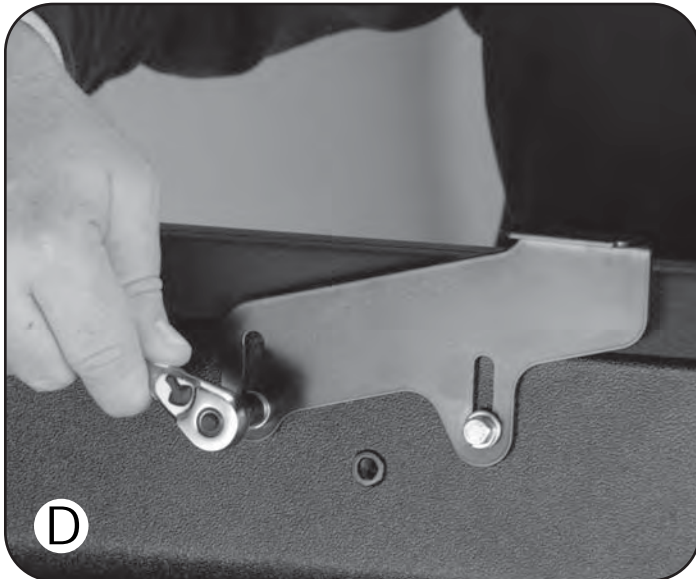

D

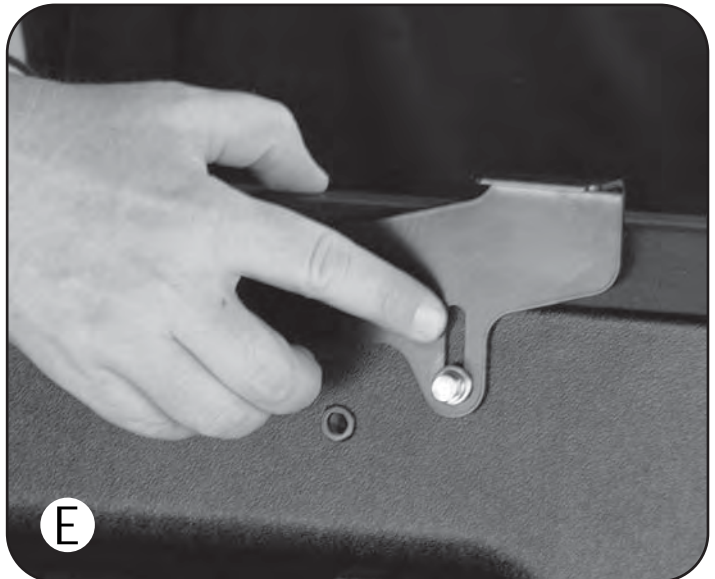

E

EASY AS 1-2-3

UNDERCOVER INSTALLATION INSTRUCTIONS



A Mounting the Ball Stud for your hydraulic strut is simple and easy. **Page 6 Picture A** demonstrates what the finished hook-up will look like.

B In the center of the bed is a Torx Bolt # T-30. You will need a Torx T-30 to remove this bolt. Again, like the plastic tabs from the rear mounting bracket you should save this bolt for future needs. See **Page 6, Picture B**.

C Once you have removed the Torx Bolt you can now hand thread the Ball Stud included with your hardware. Secure the Ball Stud with a 1/2" wrench or socket set. **BE SURE AND DO NOT OVER-TIGHTEN DOWN. DOING SO CAN SHEAR-OFF THE BALL STUD AND CAUSE SERIOUS DIFFICULTY CORRECTING.**

D Once your UnderCover is installed you will be able to lift the cover up and clip on the strut and mount it to the ball stud. See **Page 6, Picture C**.



WARNING! Be sure and do not over-tighten the rear-mounting bolts. Doing so can shear-off the bolt heads, creating a difficult procedure to remove the remaining thread.

UNDERCOVER INSTALLATION INSTRUCTIONS

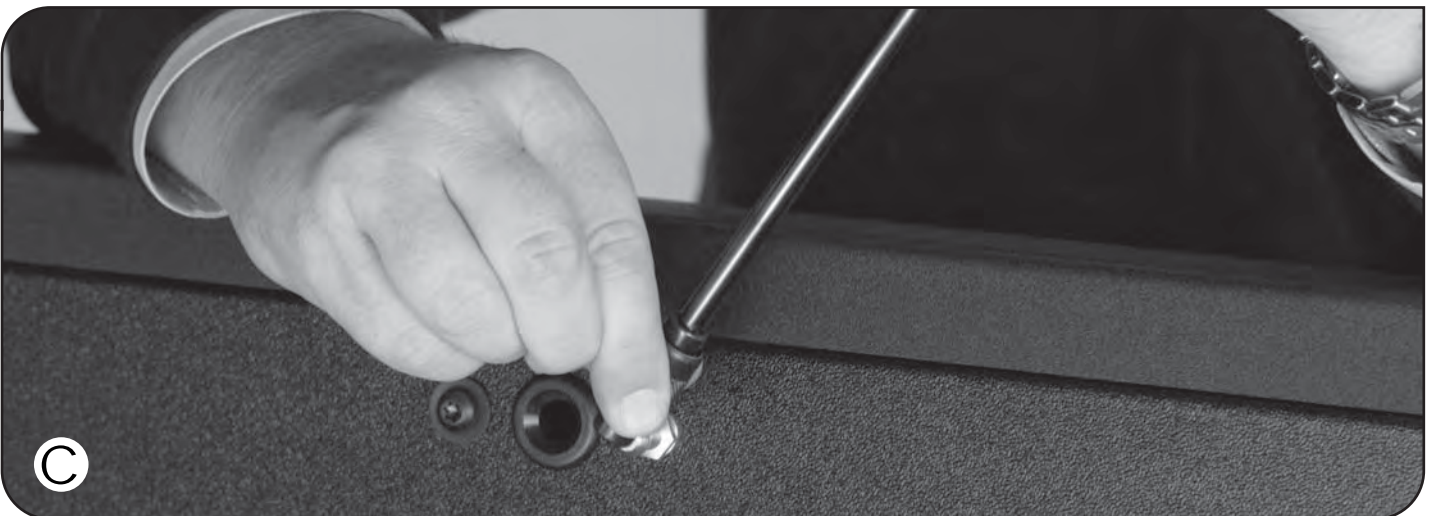
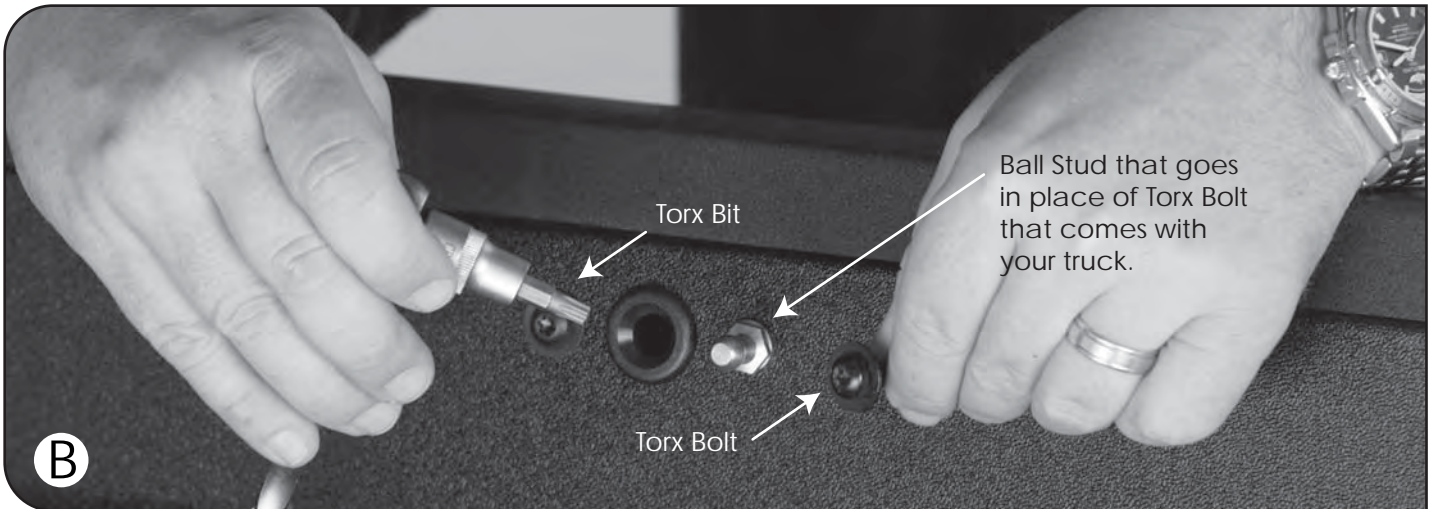

EASY AS 1-2-3

UNDERCOVER INSTALLATION INSTRUCTIONS



FACT:
Undercover's
ABS-Composite
material makes
it the strongest
and most
durable tonneau
on the market.



A Like the rear-mounting bracket installing the front bracket is much the same. Remove the plastic studs exposing the 3 preset bolt holes located at the front of the bed. **See Page 8, Picture A** for a complete look at how the front bracket will look when completely installed.

B Place the front bracket included in your hardware kit in place over the 3 preset bolt holes. See Figure 1. Hand screw in three 6mm bolts with washers. Tighten down using 10mm socket or wrench. **BE SURE TO NOT OVER-TIGHTEN OR YOU COULD SHEAR-OFF THE BOLT HEAD CAUSING A SERIOUS REPAIR ISSUE TO REMOVE THE REMAINING THREAD. See Page 8 Picture B.** On **Page 8 Figure 2** shows how your 4-bar hinge will fit on the bracket you just installed.

C Repeat this process on the opposite side. Once completed you will have the front mounting bracket firmly in place and ready to install the cover.

D Now you are ready to set your cover on the truck. Look at **Page 9 Picture F**. You must slide the 4-Bar Hinge Bracket attached to the cover over the mounting post. Look again at **Page 8 Figure 2**, as to how the 4-Bar Hinge fits over the post.

E With the hinge slot sitting over the post the cover will be sitting about 1-inch over the tailgate **Page 9 Picture F**. From this position you can now push the cover firmly into position securing the 4-Bar Hinge to the post. See **Page 9 Picture G**.

F Now with someone assisting, lift cover up keeping the pressure pushing the cover forward. Reach inside the cover and screw in the 2 fastening knobs. Only hand tighten down. **See Page 9, Picture H.**

G Your cover is now ready for Step 4.

UNDERCOVER INSTALLATION INSTRUCTIONS

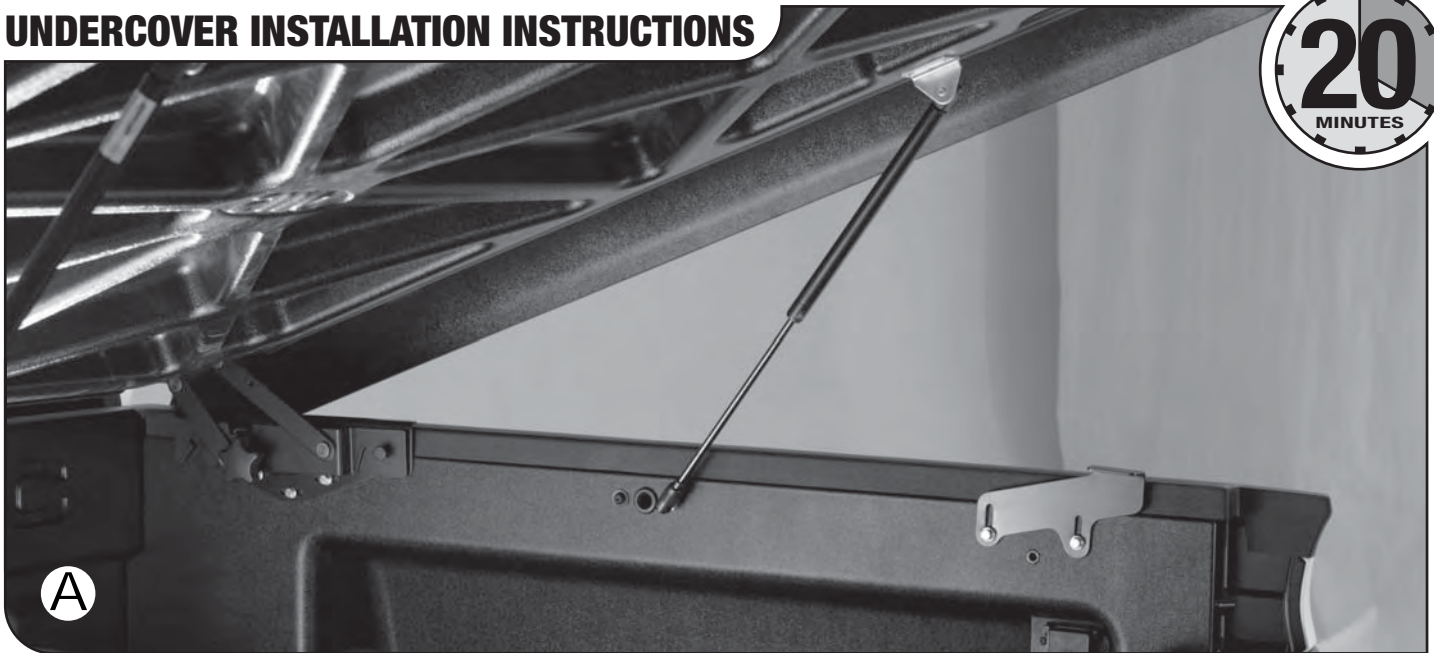

A

Figure 1

FRONT BRACKET

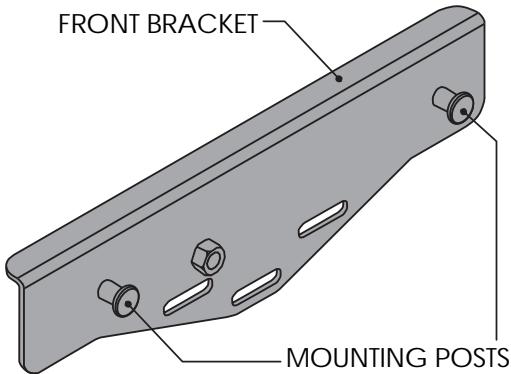

MOUNTING POSTS



B



C

Figure 2

FRONT BRACKET
MOUNTED TO BED RAIL

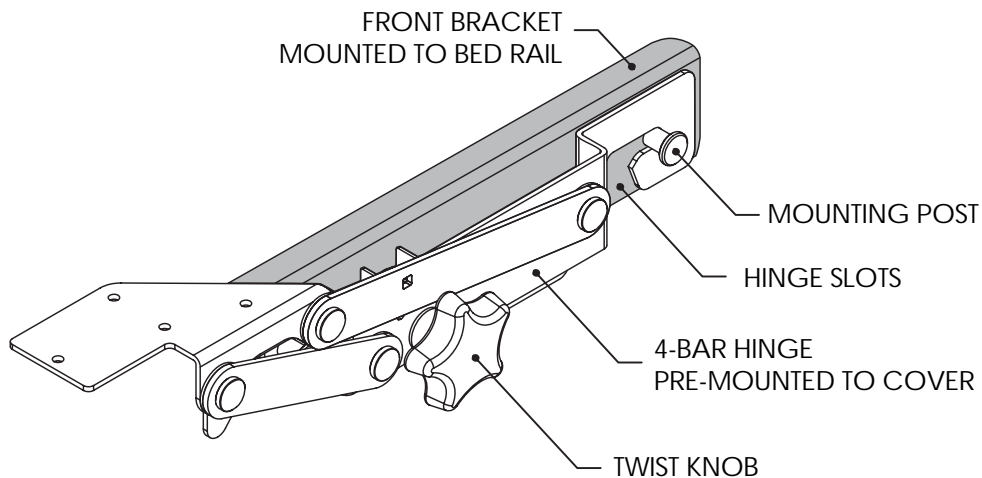

MOUNTING POST

HINGE SLOTS

4-BAR HINGE
PRE-MOUNTED TO COVER

TWIST KNOB

UNDERCOVER INSTALLATION INSTRUCTIONS



Slots on 4 bar hinge should be sitting on mounting post ready to be pushed into position.



**TEST FIT COVER PROPERLY BEFORE FINAL
SECURING OF KNOBS AND CLAMPS.**



With your cover installed, including Hydraulic Struts (see Step 4) leave your tailgate open and cover closed. Check locks to see if they line-up properly and the strike cams slide under lock plate without any resistance. If there is resistance, you can adjust lock plate with 10mm wrench.

If your cover is not square with the bed, the locks will look out of position with each other. If this is the case you will need to adjust only the front brackets.

Depending on which side is not hitting the lock plate properly, you will need to slide that side's Front Bracket either forward or backward slightly, to bring the cam into proper position with the lock plate. If this does not work, go to the opposite side and move front bracket back until the lock lines up.

Any questions you can call tech assistance Monday through Friday, 8 a.m. – 5 p.m. (866) 900.8800.

Once locks line-up properly, close tailgate. You can then feel around the outer edge of the cover, as it should have a similar gap all the way around your truck and should **NOT** be touching anywhere. If this is good, go back and tighten all clamps and knobs.



Very Important: Periodically check your truck for rubbing. Make slight adjustments when necessary. More information on Step 4.

If you have any Warranty questions, call: 866-900-8800.

EASY AS 1-2-3

UNDERCOVER INSTALLATION INSTRUCTIONS



FACT:

In less than one minute, you can both take on and off the Undercover tonneau. Fastest removal system in the industry.

A Install hydraulic struts making sure **LARGE** end of strut is attached to the tonneau, and **SMALL** or rod end is attached to the ball stud on rear bracket **Page 12, Figure 7, Picture A.**

B Be sure that the front flap seal hangs on the bulkhead plate and is not rolled under the tonneau after installation. If flap seal is rolled under the tonneau, open the tonneau and from the inside use a yardstick or something similar to push the flap seal out from under the tonneau and over the bulkhead.

C Close tonneau and check length on the truck. There should be 1/8" -to- 3/8" gap between the tailgate and the tonneau. If this is not correct, adjust by moving front brackets forward or back to achieve correct length. See **Page 10** for further instructions. Front brackets may also have to be adjusted independently to "square-up" tonneau on some truck beds.

D Adjust lock strikes **Page 12, Picture B.** When adjusted properly you should be able to turn the key to the locked position without having to push down on the tonneau. There should be a very slight amount of play between the lock cam and lock strike. A good rule of thumb is to adjust the lock to have approximately 1/8" gap between the cam and lock strike with the truck tailgate down. This usually gives you the proper adjustment after the tailgate is shut **Page 12, Figure 9, Picture C.**



WARNING: It is very important to be able to turn the key without any resistance. Do not try to force the lock cam to turn if you encounter resistance. This could result in a broken key or broken lock. Adjustment may be necessary to the lock strike plate to achieve a smooth turn without any resistance.

UNDERCOVER INSTALLATION INSTRUCTIONS



Figure 7

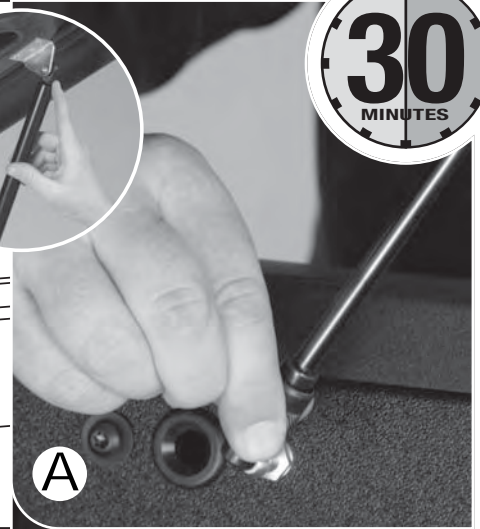
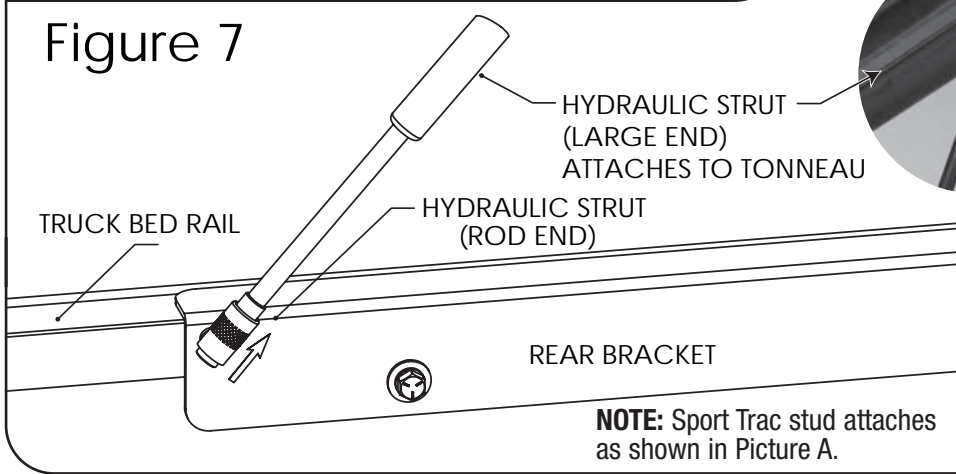

Figure 8

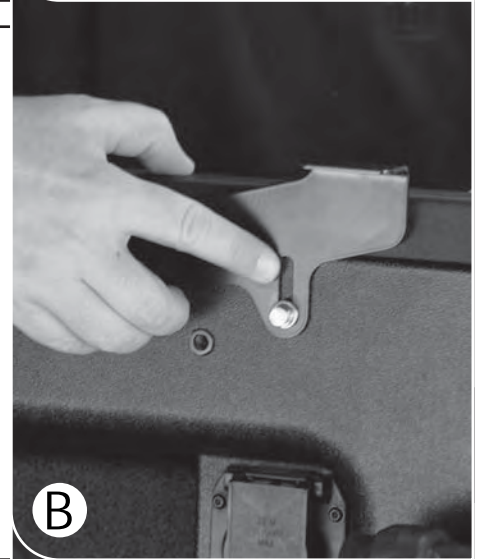
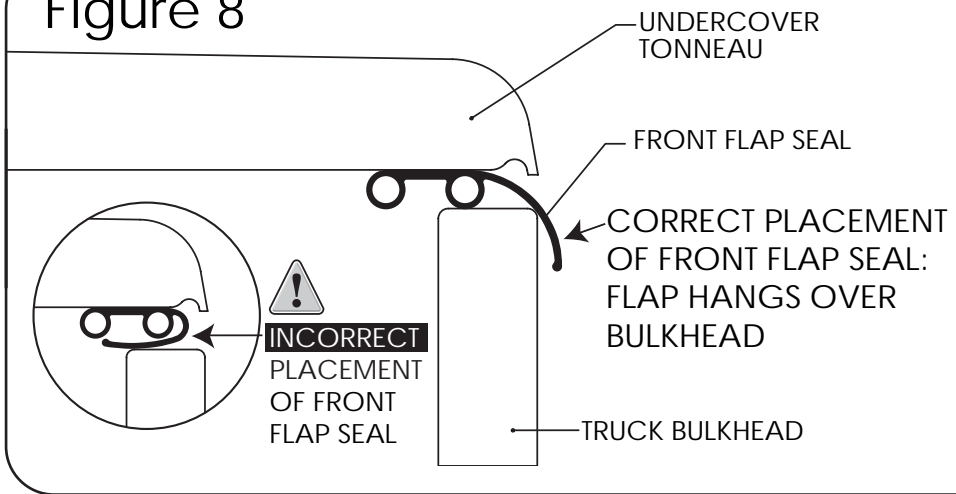
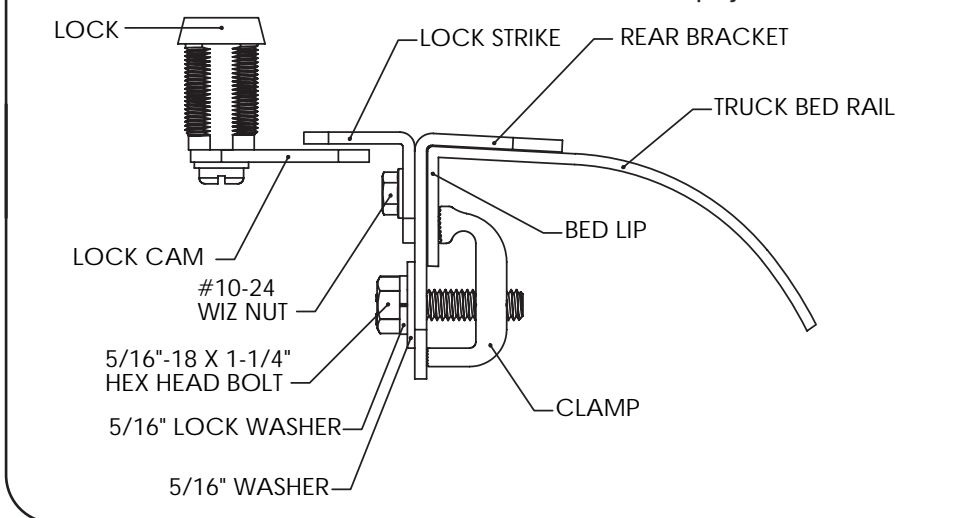

Figure 9

NOTE: Sport Trac Strike Plate is mounted to bracket as shown in Picture C. There is no clamp system.



Congratulations! Your 30-minute installation job is now complete. Now, in less than one minute, you will be able to put on and take off your tonneau cover.

UNDERCOVER REMOVAL & REINSTALLATION INSTRUCTIONS

1 Minute Removal

STEP 1 Release strut off of ball stud. Holding tonneau up with one hand, place loose end of strut on storage clip **Picture C**. Repeat for the other side **Picture A**.

STEP 2 Turn twist knobs until they release, **Picture B**.

STEP 3 Go to back of truck and pull Tonneau cover back, releasing the post from the hinge slot, **Picture D**. You are now ready to lift the cover off. Just pull the cover back releasing it from the mounting post.

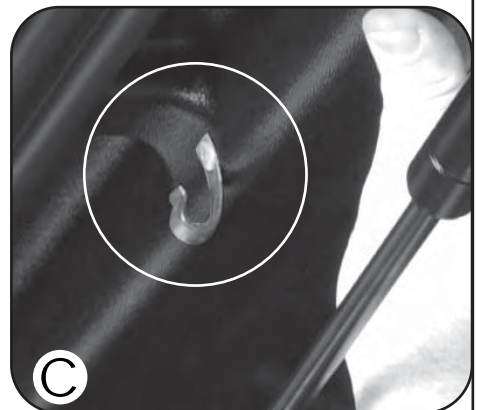
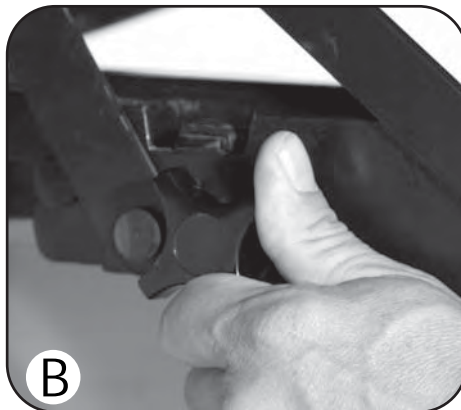
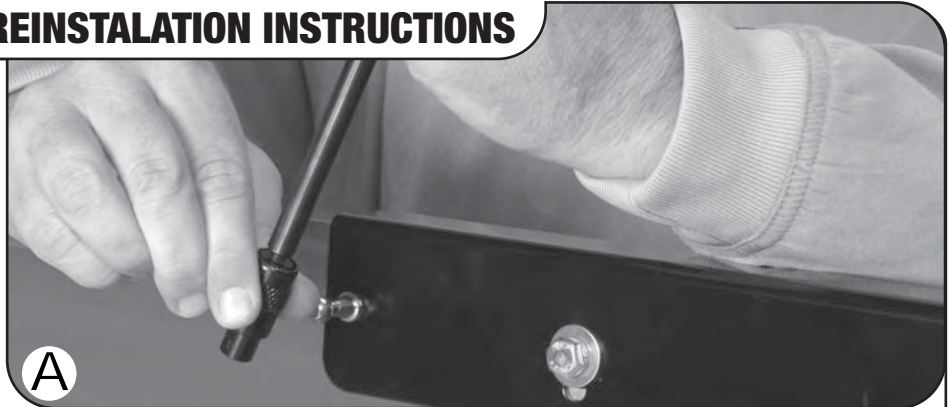

1 Minute Re-Install

STEP 1 Place tonneau on the truck. Follow instructions on Page 7, starting at **Section D**.

STEP 2 Be sure that the front flap seal is hanging over the bulkhead, not rolled under the tonneau after installation **Picture E**.

STEP 3 Reinstall struts **Page 11, Section A, Figure 7**, also **Page 13 Picture G**.

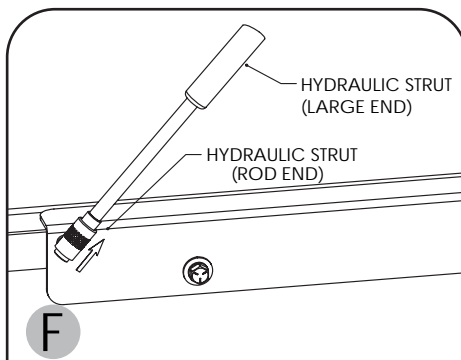
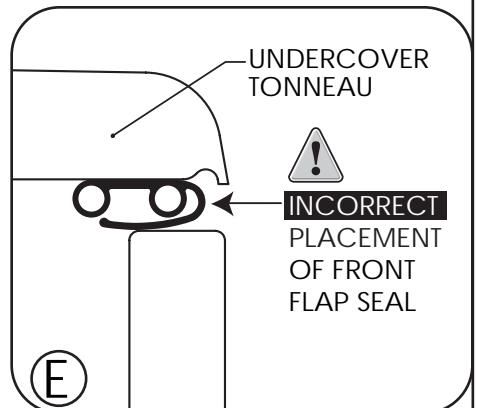

UNDERCOVER WALL HANGING INSTRUCTIONS

STEP 1 Prior to removing the tonneau, mount the two J-Hooks provided on the garage wall. The hooks must have a minimum height from the floor of 84", and be 32" on center horizontally apart **Picture A & B**. Mount hooks onto 2x4 board that is mounted into drywall studs.

STEP 2 Remove your tonneau from the truck bed according to instructions on page 9, 1-Minute Removal.

STEP 3 Hang tonneau vertically on the wall-mounted J-Hooks, with the underside against the wall inserting J-Hooks into the holes provided in **Picture C**.

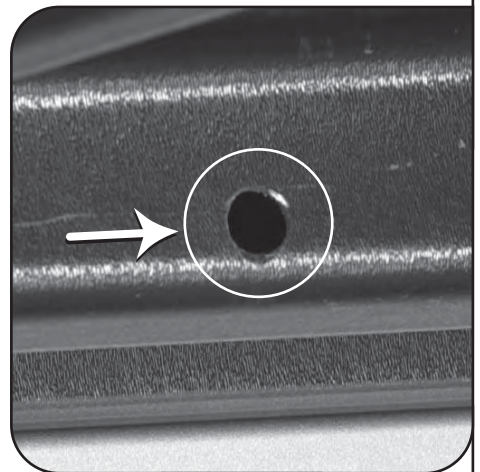
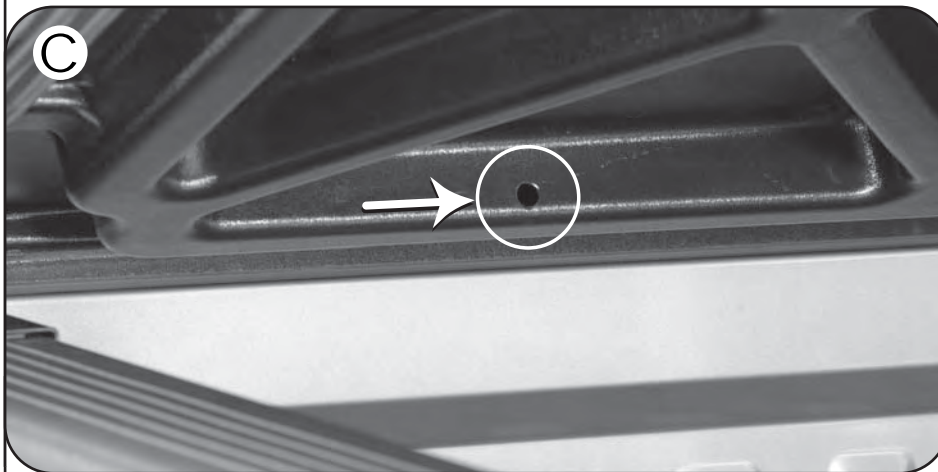
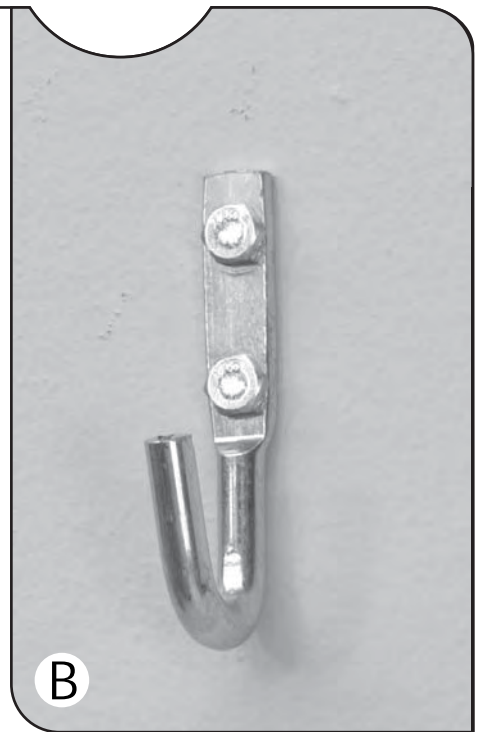
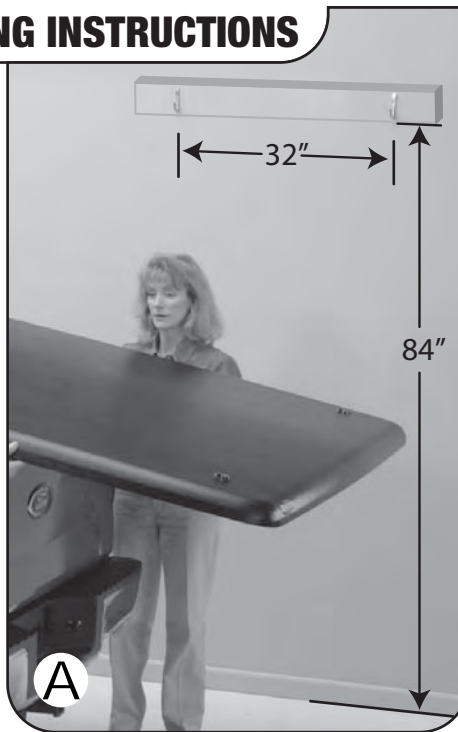

UNDERCOVER SERIAL NUMBER LOCATION

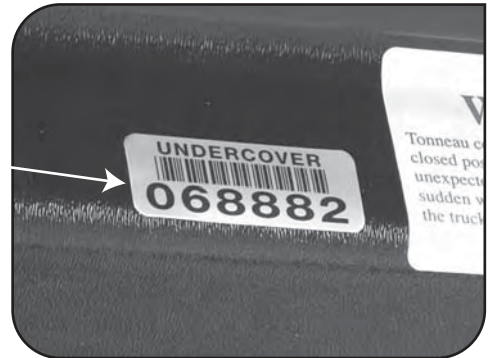
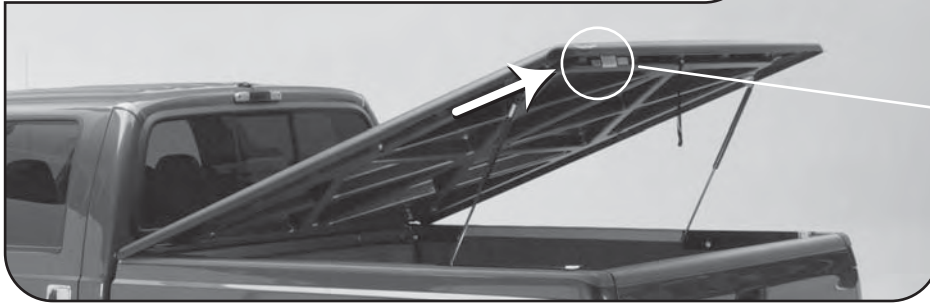

THANK YOU!

Congratulations! You've just installed the fastest-selling, highest-quality tonneau in the industry. Thank you very much for your purchase of UnderCover!

Steve Brallier

**Steve Brallier
President
E.D. Industries/UnderCover**



© 2007 E.D. Industries, Inc. All rights reserved.

E.D. Industries/UnderCover
P.O. Box 620
Rogersville, MO 65742
(417) 753-8000
(866) 900-8800
www.undercoverinfo.com
sales@undercoverinfo.com

For any Warranty issues, contact UnderCover Directly.

