

The ADAPT Toolkit: Implementing Interoperability in Precision Agriculture



Interoperability has been a formidable hurdle to the use of precision ag technologies. ADAPT provides an easy-to-use industry framework, with the tools to simplify communication between growers, their machines, and their partners.

"The as-is state of precision ag data management is frustrating to say the least... Widespread acceptance and use of the new ADAPT framework will reduce our effort and frustration greatly."

– Luke Lightfoot, Ag Technology Manager at Co-Alliance, LLP, an Indiana ag cooperative



Adopt ADAPT! (Here's why...)

Different brands of farm equipment and software currently collect and consume data in a variety of proprietary file formats. While this is a natural consequence of how the industry has grown, it makes it hard for end-users to "connect the dots" and extract value from the data.

The promise of seamless interoperability among precision ag systems – regardless of the system manufacturer – has entered an exciting new stage with AgGateway's ADAPT framework. ADAPT (Agricultural Data Application Programming Toolkit) eliminates this barrier to the broad use of precision agriculture data, by easily enabling interoperability between different software and hardware applications.

ADAPT contains:

- A common object model for field operations.
- A set of data conversion plug-ins (both open source and proprietary).
- A plug-in management framework (a software development kit) that enables all the parts to work together.

Development of plug-ins will enable ADAPT's broad adoption. A major goal of the ADAPT team (which is governed by AgGateway's ADAPT Committee) is to reach the point where plug-ins exist to convert between the common object model and all the formats of interest to the industry. The ADAPT team is writing some fundamental plug-ins (one for ISO11783 files, another for the serialization of ADAPT for FMIS-to-FMIS communication). Manufacturers and third parties are encouraged to write plug-ins for their formats of interest; the ADAPT team is creating a variety of support documents and tools to make this easier.

ADAPT is an open-source project, allowing stakeholders worldwide to use the software and to contribute to its continued development. The toolkit has been developed over several years by a large, collaborative group of AgGateway members from a variety of manufacturer and farm management information system (FMIS) software companies, who all recognized that the grower and other agricultural users have a critical need to use data from multiple sources in field operations decision-making. ADAPT's open-source structure now encourages participation by everyone – AgGateway members and non-members alike.

More ADAPT Features

- **Simple to use:** A common object model that you can use in your farm management software. Plug-in libraries that allow the farm management software to convert to and from the common object model and different file formats.
- **Eclipse Public License 1.0:** The open-source license allows you to include ADAPT in your software and modify it if needed.
- **Plug-ins are licensed by their developer:** Anyone can build a plug-in for ADAPT; the developer is free to license their plug-in based on their business needs.
- **Farm Management Information System (FMIS) companies** are responsible for the implementation of reading and writing to/from the object model.
- **Cross platform:** ADAPT can run on Windows, Mac or Linux if your platform runs the .NET Framework or Mono.
- **Strong support for different geographies, languages and geopolitical contexts.**

The ADAPT Toolkit

[continued]



ADAPT's Mission

To support the ongoing process of providing open-source solutions to enhance interoperability between systems that create and manage agricultural data.

The ADAPT Committee is composed of two teams, Business and Technical.

ADAPT Members

As of July 18, 2016

Ag Connections, Ag Leader, AGCO, Agrian, CNH Industrial, Central Valley Ag Coop, CLAAS, Independent Data Management, John Deere, Land O' Lakes, Monsanto, Premier Crop Systems, ProAg, Raven Industries, Software Solutions Integrated, SST Software, Syngenta, Topcon Precision Agriculture, Trimble, Uptake and ZedX

Questions?

Email us at:

Adapt.Feedback@AgGateway.org

For more information, including materials for joining ADAPT, visit:

<http://www.AdaptFramework.org>

www.AgGateway.org

Member.Services@AgGateway.org

Phone: (+1) 866.251.8618

Twitter: @AgGateway

How ADAPT works to enable data conversion

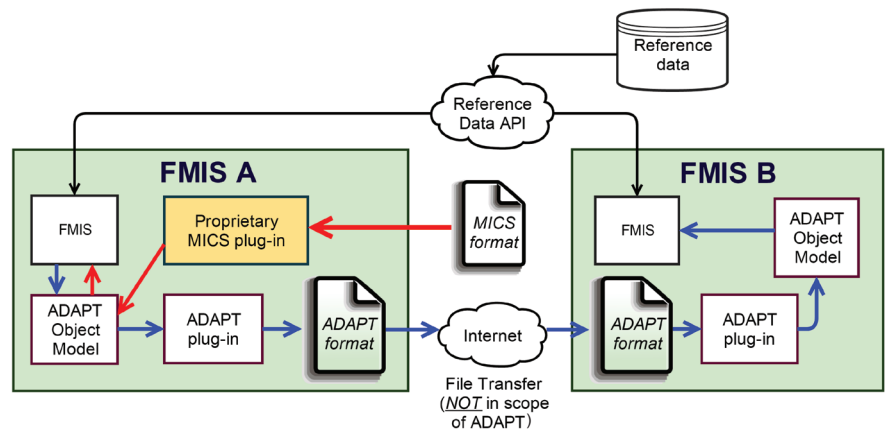

The figure above shows two examples of data conversions and flows.

Incoming data from a Machine and Implement Control System (MICS, i.e., the controller in the cab.

Data flow shown in red: A proprietary-format data file coming from a controller in the field is converted by a manufacturer-specific plug-in into an instance of the object model; a Farm Management Information System ("FMIS A") consumes the data.

Communication between Farm Management Information Systems (FMIS, i.e., farm management software. Data flow shown in blue): FMIS A creates an instance of the object model, populates it with the data it wants to transmit, and uses the ADAPT plug-in to serialize it to a file. This ADAPT-formatted file is transmitted to another FMIS using the Internet or another means. (File transport is out of scope of ADAPT, accommodating different solutions available in the industry.) FMIS B uses the ADAPT plug-in to convert the ADAPT-formatted file to an instance of the object model, and then consumes the data.

Note how FMIS A and FMIS B are both supported by Reference Data, a distributed system of common unique identifiers for products to be shared across the industry by manufacturers and third-party data providers.

A Robust, Open-Source Project

The ADAPT team is working in the context of the continuing cooperation between AgGateway and relevant standards organizations such as the **Agricultural Industry Electronic Foundation (AEF)**, which implements the **ISO 11783 standard**.

ADAPT has received the bulk of its requirements from AgGateway's SPADE (<http://bit.ly/26vg7ry>) and PAIL (<http://bit.ly/1S269kR>) projects.

Remember: You can contribute to ADAPT without being an AgGateway member!

How you can get involved

Go to www.ADAPTFramework.org to review the ADAPT model and to access a growing set of resources to help with implementation!