

MAIN OFFICE

INTERNATIONAL TOOL MANUFACTURING
71-08 51ST. AVENUE, WOODSIDE, NY 11377
(718) 446-0711 • (800) 247-5696 • FAX (718) 899-6553

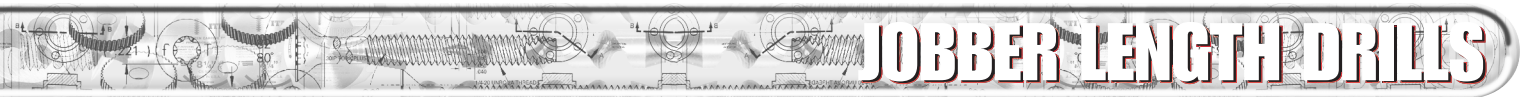

INTERNATIONAL TOOL MANUFACTURING
675-E-PROGRESS CENTER AVE., LAWRENCEVILLE, GA 30043
(770) 962-5454 • (800) 229-1776 • FAX (770) 962-5869



GENERAL PURPOSE DRILLS HSS

**118°
POINT**



SERIES 200HS FRACTIONAL SIZES

TWO TONE FINISH

PART NUMBER	DRILL SIZE	DEC. EQUIV.	O/A LENGTH	FLUTE LENGTH	PRICE EACH
200HS0464	1/16"	.0625	1-7/8"	7/8"	\$0.73
200HS0564	5/64"	.0781	2"	1"	\$0.73
200HS0664	3/32"	.0938	2-1/4"	1-1/4"	\$0.73
200HS0764	7/64"	.1094	2-5/8"	1-1/2"	\$0.73
200HS0864	1/8"	.1250	2-3/4"	1-5/8"	\$0.73
200HS0964	9/64"	.1406	2-7/8"	1-3/4"	\$0.79
200HS1064	5/32"	.1562	3-1/8"	2"	\$0.82
200HS1164	11/64"	.1719	3-1/4"	2-1/8"	\$0.91
200HS1264	3/16"	.1875	3-1/2"	2-5/16"	\$1.01
200HS1364	13/64"	.2031	3-5/8"	2-7/16"	\$1.17
200HS1464	7/32"	.2188	3-3/4"	2-1/2"	\$1.28
200HS1564	15/64"	.2344	3-7/8"	2-5/8"	\$1.50
200HS1664	1/4"	.2500	4"	2-3/4"	\$1.68
200HS1764	17/64"	.2656	4-1/8"	2-7/8"	\$2.11
200HS1864	9/32"	.2812	4-1/4"	2-15/16"	\$2.40

PART NUMBER	DRILL SIZE	DEC. EQUIV.	O/A LENGTH	FLUTE LENGTH	PRICE EACH
200HS1964	19/64"	.2969	4-3/8"	3-1/16"	\$2.59
200HS2064	5/16"	.3125	4-1/2"	3-3/16"	\$2.65
200HS2164	21/64"	.3281	4-5/8"	3-5/16"	\$3.00
200HS2264	11/32"	.3438	4-3/4"	3-7/16"	\$3.47
200HS2364	23/64"	.3594	4-7/8"	3-1/2"	\$3.91
200HS2464	3/8"	.3750	5"	3-5/8"	\$4.02
200HS2564	25/64"	.3906	5-1/8"	3-3/4"	\$4.35
200HS2664	13/32"	.4062	5-1/4"	3-1/8"	\$4.47
200HS2764	27/64"	.4219	5-3/8"	3-15/16"	\$4.95
200HS2864	7/16"	.4375	5-1/2"	4-1/16"	\$5.32
200HS2964	29/64"	.4531	5-5/8"	4-3/16"	\$6.27
200HS3064	15/32"	.4688	5-3/4"	4-5/16"	\$6.38
200HS3164	31/64"	.4844	5-7/8"	4-3/8"	\$6.74
200HS3264	1/2"	.5000	6"	4-1/2"	\$6.85

- Jobber Length
- Straight Shank
- Bright Shank
- Black Flute
- Roll Forged
- M2 High Speed Steel
- Suitable for
 - Cast Iron
 - Steel
 - Steel Forging
 - Other Work Materials

IMPORTED

SIZES THROUGH 5/16" ARE PACKAGED 12/ PACK. SIZES 21/64" → 1/2" ARE PACKAGED 6/ PACK.



GENERAL PURPOSE DRILLS HSS

**118°
POINT**



SERIES 200BF FRACTIONAL SIZES

BLACK FINISH

PART NUMBER	DRILL SIZE	DEC. EQUIV.	O/A LENGTH	FLUTE LENGTH	PRICE EACH
200BF0464	1/16"	.0625	1-7/8"	7/8"	\$0.64
200BF0564	5/64"	.0781	2"	1"	\$0.64
200BF0664	3/32"	.0938	2-1/4"	1-1/4"	\$0.64
200BF0764	7/64"	.1094	2-5/8"	1-1/2"	\$0.64
200BF0864	1/8"	.1250	2-3/4"	1-5/8"	\$0.64
200BF0964	9/64"	.1406	2-7/8"	1-3/4"	\$0.70
200BF1064	5/32"	.1562	3-1/8"	2"	\$0.72
200BF1164	11/64"	.1719	3-1/4"	2-1/8"	\$0.81
200BF1264	3/16"	.1875	3-1/2"	2-5/16"	\$0.89
200BF1364	13/64"	.2031	3-5/8"	2-7/16"	\$1.03
200BF1464	7/32"	.2188	3-3/4"	2-1/2"	\$1.13
200BF1564	15/64"	.2344	3-7/8"	2-5/8"	\$1.32
200BF1664	1/4"	.2500	4"	2-3/4"	\$1.48
200BF1764	17/64"	.2656	4-1/8"	2-7/8"	\$1.86
200BF1864	9/32"	.2812	4-1/4"	2-15/16"	\$2.12

PART NUMBER	DRILL SIZE	DEC. EQUIV.	O/A LENGTH	FLUTE LENGTH	PRICE EACH
200BF1964	19/64"	.2969	4-3/8"	3-1/16"	\$2.29
200BF2064	5/16"	.3125	4-1/2"	3-3/16"	\$2.34
200BF2164	21/64"	.3281	4-5/8"	3-5/16"	\$2.65
200BF2264	11/32"	.3438	4-3/4"	3-7/16"	\$3.07
200BF2364	23/64"	.3594	4-7/8"	3-1/2"	\$3.45
200BF2464	3/8"	.3750	5"	3-5/8"	\$3.55
200BF2564	25/64"	.3906	5-1/8"	3-3/4"	\$3.84
200BF2664	13/32"	.4062	5-1/4"	3-7/8"	\$3.95
200BF2764	27/64"	.4219	5-3/8"	3-15/16"	\$4.38
200BF2864	7/16"	.4375	5-1/2"	4-1/16"	\$4.69
200BF2964	29/64"	.4531	5-5/8"	4-3/16"	\$5.53
200BF3064	15/32"	.4688	5-3/4"	4-5/16"	\$5.63
200BF3164	31/64"	.4844	5-7/8"	4-3/8"	\$5.95
200BF3264	1/2"	.5000	6"	4-1/2"	\$6.05

- Jobber Length
- Straight Shank
- Black Shank
- Black Flute
- Roll Forged
- M2 High Speed Steel
- Suitable for
 - Cast Iron
 - Steel
 - Steel Forging
 - Other Work Materials

IMPORTED

i GENERAL PURPOSE JOBBER DRILL SETS AVAILABLE ON PAGE 22 → 25. REDUCED SHANK DRILL BITS AVAILABLE ON PAGE 13.

MAIN OFFICE

INTERNATIONAL TOOL MANUFACTURING
71-08 51ST. AVENUE, WOODSIDE, NY 11377
(718) 446-0711 • (800) 247-5696 • FAX (718) 899-6553



INTERNATIONAL TOOL MANUFACTURING
675-E-PROGRESS CENTER AVE., LAWRENCEVILLE, GA 30043
(770) 962-5454 • (800) 229-1776 • FAX (770) 962-5869

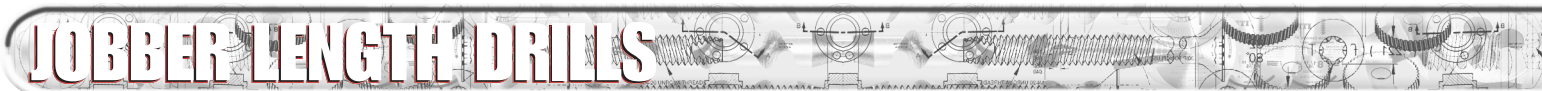

**118°
POINT**

GENERAL PURPOSE DRILLS HSS

SERIES 250US FRACTIONAL SIZES

BRIGHT FINISH

PART NUMBER	DRILL SIZE	DEC. EQUIV.	O/A LENGTH	FLUTE LENGTH	PRICE EACH
250US0164	1/64"	.0156	3/4"	3/16"	\$1.39
250US0264	1/32"	.0312	1-3/8"	1/2"	\$1.39
250US0364	3/64"	.0469	1-3/4"	3/4"	\$1.39
250US0464	1/16"	.0625	1-7/8"	7/8"	\$0.84
250US0564	5/64"	.0781	2"	1"	\$0.90
250US0664	3/32"	.0938	2-1/4"	1-1/4"	\$0.90
250US0764	7/64"	.1094	2-5/8"	1-1/2"	\$0.90
250US0864	1/8"	.1250	2-3/4"	1-5/8"	\$0.90
250US0964	9/64"	.1406	2-7/8"	1-3/4"	\$1.00
250US1064	5/32"	.1562	3-1/8"	2"	\$1.04
250US1164	11/64"	.1719	3-1/4"	2-1/8"	\$1.14
250US1264	3/16"	.1875	3-1/2"	2-5/16"	\$1.26
250US1364	13/64"	.2031	3-5/8"	2-7/16"	\$1.46
250US1464	7/32"	.2188	3-3/4"	2-1/2"	\$1.63
250US1564	15/64"	.2344	3-7/8"	2-5/8"	\$1.87
250US1664	1/4"	.2500	4"	2-3/4"	\$2.11

PART NUMBER	DRILL SIZE	DEC. EQUIV.	O/A LENGTH	FLUTE LENGTH	PRICE EACH
250US1764	17/64"	.2656	4-1/8"	2-7/8"	\$2.63
250US1864	9/32"	.2812	4-1/4"	2-15/16"	\$3.00
250US1964	19/64"	.2969	4-3/8"	3-1/16"	\$3.23
250US2064	5/16"	.3125	4-1/2"	3-3/16"	\$3.33
250US2164	21/64"	.3281	4-5/8"	3-5/16"	\$3.75
250US2264	11/32"	.3438	4-3/4"	3-7/16"	\$4.27
250US2364	23/64"	.3594	4-7/8"	3-1/2"	\$4.88
250US2464	3/8"	.3750	5"	3-5/8"	\$5.03
250US2564	25/64"	.3906	5-1/8"	3-3/4"	\$5.45
250US2664	13/32"	.4062	5-1/4"	3-1/8"	\$5.60
250US2764	27/64"	.4219	5-3/8"	3-15/16"	\$6.20
250US2864	7/16"	.4375	5-1/2"	4-1/16"	\$6.64
250US2964	29/64"	.4531	5-5/8"	4-3/16"	\$7.83
250US3064	15/32"	.4688	5-3/4"	4-5/16"	\$7.96
250US3164	31/64"	.4844	5-7/8"	4-3/8"	\$8.46
250US3264	1/2"	.5000	6"	4-1/2"	\$8.56

- Jobber Length
- Straight Shank
- Ground Flute
- M2 High Speed Steel
- Suitable for
 - Cast Iron
 - Steel
 - Steel Forging
 - Other Work Materials

MADE IN U.S.A.

SIZES THROUGH 5/16" ARE PACKAGED 12/ PACK.
SIZES 21/64" → 1/2" ARE PACKAGED 6/ PACK.



**135°
SPLIT
POINT**

TRITON HEAVY DUTY DRILLS SUPER HSS

SERIES 206SP FRACTIONAL SIZES

BLACK OXIDE FINISH

PART NUMBER	DRILL SIZE	DEC. EQUIV.	O/A LENGTH	FLUTE LENGTH	PRICE EACH
206SP0464	1/16"	.0625	1-7/8"	7/8"	\$1.06
206SP0564	5/64"	.0781	2"	1"	\$1.06
206SP0664	3/32"	.0938	2-1/4"	1-1/4"	\$1.06
206SP0764	7/64"	.1094	2-5/8"	1-1/2"	\$1.06
206SP0864	1/8"	.1250	2-3/4"	1-5/8"	\$1.18
206SP0964	9/64"	.1406	2-7/8"	1-3/4"	\$1.26
206SP1064	5/32"	.1562	3-1/8"	2"	\$1.32
206SP1164	11/64"	.1719	3-1/4"	2-1/8"	\$1.49
206SP1264	3/16"	.1875	3-1/2"	2-5/16"	\$1.61
206SP1364	13/64"	.2031	3-5/8"	2-7/16"	\$1.92
206SP1464	7/32"	.2188	3-3/4"	2-1/2"	\$1.95
206SP1564	15/64"	.2344	3-7/8"	2-5/8"	\$2.24
206SP1664	1/4"	.2500	4"	2-3/4"	\$2.55
206SP1764	17/64"	.2656	4-1/8"	2-7/8"	\$2.82
206SP1864	9/32"	.2812	4-1/4"	2-15/16"	\$3.49

PART NUMBER	DRILL SIZE	DEC. EQUIV.	O/A LENGTH	FLUTE LENGTH	PRICE EACH
206SP1964	19/64"	.2969	4-3/8"	3-1/16"	\$3.77
206SP2064	5/16"	.3125	4-1/2"	3-3/16"	\$3.91
206SP2164	21/64"	.3281	4-5/8"	3-5/16"	\$4.31
206SP2264	11/32"	.3438	4-3/4"	3-7/16"	\$4.83
206SP2364	23/64"	.3594	4-7/8"	3-1/2"	\$5.48
206SP2464	3/8"	.3750	5"	3-5/8"	\$5.52
206SP2564	25/64"	.3906	5-1/8"	3-3/4"	\$6.36
206SP2664	13/32"	.4062	5-1/4"	3-7/8"	\$6.45
206SP2764	27/64"	.4219	5-3/8"	3-15/16"	\$7.11
206SP2864	7/16"	.4375	5-1/2"	4-1/16"	\$7.57
206SP2964	29/64"	.4531	5-5/8"	4-3/16"	\$8.86
206SP3064	15/32"	.4688	5-3/4"	4-5/16"	\$8.90
206SP3164	31/64"	.4844	5-7/8"	4-3/8"	\$9.36
206SP3264	1/2"	.5000	6"	4-1/2"	\$9.45

- Jobber Length
- Straight Shank
- Thicker Web to Provide Extra Strength & Rigidity
- Ground Flute
- M2 High Speed Steel
- Suitable for
 - Cast Iron
 - Steel
 - Steel Forging
 - Stainless Steel

IMPORTED



BRIGHT FINISH & TRITON HEAVY DUTY JOBBER DRILL SETS AVAILABLE ON PAGES 22 → 23. REDUCED SHANK DRILL BITS AVAILABLE ON PAGES 13.



JOBBER LENGTH DRILLS



**MADE
 IN THE
 USA**

SUPERBA HEAVY DUTY DRILLS SUPER HSS

**135°
 SPLIT
 POINT**



SERIES 206US FRACTIONAL SIZES

BLACK OXIDE & GOLD FINISH

PART NUMBER	DRILL SIZE	DEC. EQUIV.	O/A LENGTH	FLUTE LENGTH	PRICE EACH
206US0464	1/16"	.0625	1-7/8"	7/8"	\$1.39
206US0564	5/64"	.0781	2"	1"	\$1.39
206US0664	3/32"	.0938	2-1/4"	1-1/4"	\$1.39
206US0764	7/64"	.1094	2-5/8"	1-1/2"	\$1.39
206US0864	1/8"	.1250	2-3/4"	1-5/8"	\$1.55
206US0964	9/64"	.1406	2-7/8"	1-3/4"	\$1.66
206US1064	5/32"	.1562	3-1/8"	2"	\$1.74
206US1164	11/64"	.1719	3-1/4"	2-1/8"	\$1.97
206US1264	3/16"	.1875	3-1/2"	2-5/16"	\$2.14
206US1364	13/64"	.2031	3-5/8"	2-7/16"	\$2.53
206US1464	7/32"	.2188	3-3/4"	2-1/2"	\$2.58
206US1564	15/64"	.2344	3-7/8"	2-5/8"	\$2.94
206US1664	1/4"	.2500	4"	2-3/4"	\$3.37
206US1764	17/64"	.2656	4-1/8"	2-7/8"	\$3.71
206US1864	9/32"	.2812	4-1/4"	2-15/16"	\$4.59

PART NUMBER	DRILL SIZE	DEC. EQUIV.	O/A LENGTH	FLUTE LENGTH	PRICE EACH
206US1964	19/64"	.2969	4-3/8"	3-1/16"	\$4.96
206US2064	5/16"	.3125	4-1/2"	3-3/16"	\$5.14
206US2164	21/64"	.3281	4-5/8"	3-5/16"	\$5.67
206US2264	11/32"	.3438	4-3/4"	3-7/16"	\$6.35
206US2364	23/64"	.3594	4-7/8"	3-1/2"	\$7.22
206US2464	3/8"	.3750	5"	3-5/8"	\$7.26
206US2564	25/64"	.3906	5-1/8"	3-3/4"	\$8.37
206US2664	13/32"	.4062	5-1/4"	3-7/8"	\$8.49
206US2764	27/64"	.4219	5-3/8"	3-15/16"	\$9.35
206US2864	7/16"	.4375	5-1/2"	4-1/16"	\$9.95
206US2964	29/64"	.4531	5-5/8"	4-3/16"	\$11.66
206US3064	15/32"	.4688	5-3/4"	4-5/16"	\$11.72
206US3164	31/64"	.4844	5-7/8"	4-3/8"	\$12.32
206US3264	1/2"	.5000	6"	4-1/2"	\$12.41

- Jobber Length
- Straight Shank
- Gold & Black Oxide Finish
- Thicker Web to Provide Extra Strength & Rigidity
- M7 High Speed Steel
- Suitable for
 - Cast Iron
 - Steel
 - Steel Forging
 - Stainless Steel

MADE IN U.S.A.

SIZES THROUGH 5/16"
 ARE PACKAGED 12/ PACK.
 SIZES 21/64" → 1/2" ARE
 PACKAGED 6/ PACK.

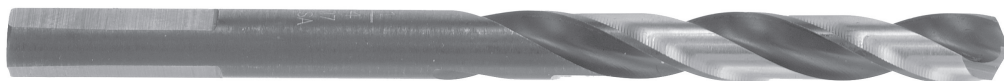

SUPERBA (MECHANICS) SUPER HSS

SERIES 208MC FRACTIONAL SIZES

BLACK OXIDE & GOLD FINISH

PART NUMBER	DRILL SIZE	DEC. EQUIV.	O/A LENGTH	FLUTE LENGTH	PRICE EACH
208MC0464	1/16"	.0625	1 7/8"	7/8"	\$1.05
208MC0564	5/64"	.0781	2"	1"	\$1.05
208MC0664	3/32"	.0938	2 1/4"	1-1/4"	\$1.21
208MC0764	7/64"	.1094	2 3/8"	1-5/16"	\$1.23
208MC0864	1/8"	.1250	2 1/2"	1-7/16"	\$1.36
208MC0964	9/64"	.1406	2 5/8"	1-9/16"	\$1.43
208MC1064	5/32"	.1562	2 3/4"	1-11/16"	\$1.75
208MC1164	11/64"	.1719	2 7/8"	1-13/16"	\$1.85
208MC1264	3/16"	.1875	3"	1-7/8"	\$2.31
208MC1364	13/64"	.2031	3 1/8"	1-15/16"	\$2.46
208MC1464	7/32"	.2188	3 1/4"	2"	\$2.74
208MC1564	15/64"	.2344	3 3/8"	2-1/16"	\$2.97
208MC1664	1/4"	.2500	3 1/2"	2"	\$3.12
208MC1764	17/64"	.2656	3 5/8"	2-1/8"	\$3.89
208MC1864	9/32"	.2812	3 3/4"	2-1/4"	\$4.13

PART NUMBER	DRILL SIZE	DEC. EQUIV.	O/A LENGTH	FLUTE LENGTH	PRICE EACH
208MC1964	19/64"	.2969	3 7/8"	2-3/8"	\$4.60
208MC2064	5/16"	.3125	4"	2-1/2"	\$4.96
208MC2164	21/64"	.3281	4 1/16"	2-9/16"	\$5.26
208MC2264	11/32"	.3438	4 1/8"	2-5/8"	\$5.72
208MC2364	23/64"	.3594	4 3/16"	2-11/16"	\$6.10
208MC2464	3/8"	.3750	4 1/4"	2-11/16"	\$6.47
208MC2564	25/64"	.3906	4 5/16"	2-3/4"	\$6.90
208MC2664	13/32"	.4062	4 3/8"	2-13/16"	\$7.44
208MC2764	27/64"	.4219	4 7/16"	2-7/8"	\$7.62
208MC2864	7/16"	.4375	4 1/2"	2-15/16"	\$8.43
208MC2964	29/64"	.4531	4 5/8"	3"	\$8.80
208MC3064	15/32"	.4688	4 3/4"	3-1/8"	\$9.63
208MC3164	31/64"	.4844	4 7/8"	3-1/4"	\$10.10
208MC3264	1/2"	.5000	5"	3-3/8"	\$10.79

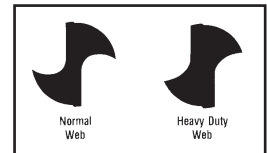

- Mechanics Length
- Sizes 3/16" → 1/2" have 3-Flat Shanks
- Gold & Black Oxide Finish
- Thicker Web to Provide Extra Strength & Rigidity
- M7 High Speed Steel
- Suitable for
 - Cast Iron
 - Steel
 - Steel Forging
 - Stainless Steel



SUPERBA HEAVY DUTY JOBBER DRILL SETS AVAILABLE ON PAGES 22 → 23.

MAIN OFFICE

INTERNATIONAL TOOL MANUFACTURING
71-08 51ST. AVENUE, WOODSIDE, NY 11377
(718) 446-0711 • (800) 247-5696 • FAX (718) 899-6553



INTERNATIONAL TOOL MANUFACTURING
675-E-PROGRESS CENTER AVE., LAWRENCEVILLE, GA 30043
(770) 962-5454 • (800) 229-1776 • FAX (770) 962-5869

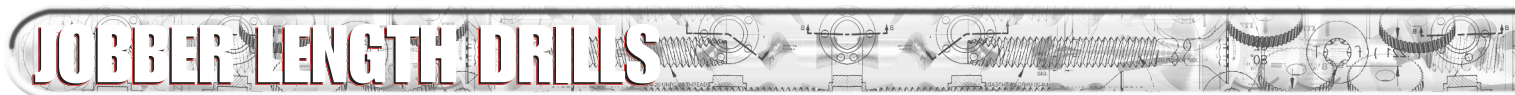

135°
SPLIT
POINT

COBALT STEEL DRILLS HSS

SERIES 219CO FRACTIONAL SIZES

GOLD FINISH

- Jobber Length
- Straight Shank
- M42 High Speed Steel
- Suitable for
 - Stainless Steel
 - Hardening Grade of Stainless Steel
 - High Temperature Alloys
 - Heat Treated Materials
 - Abrasive Plastics

PART NUMBER	DRILL SIZE	DEC. EQUIV.	O/A LENGTH	FLUTE LENGTH	PRICE EACH
219CO0464	1/16"	.0625	1-7/8"	7/8"	\$1.67
219CO0564	5/64"	.0781	2"	1"	\$1.85
219CO0664	3/32"	.0938	2-1/4"	1-1/4"	\$2.01
219CO0764	7/64"	.1094	2-5/8"	1-1/2"	\$2.13
219CO0864	1/8"	.1250	2-3/4"	1-5/8"	\$2.42
219CO0964	9/64"	.1406	2-7/8"	1-3/4"	\$2.59
219CO1064	5/32"	.1562	3-1/8"	2"	\$2.86
219CO1164	11/64"	.1719	3-1/4"	2-1/8"	\$3.03
219CO1264	3/16"	.1875	3-1/2"	2-5/16"	\$3.32
219CO1364	13/64"	.2031	3-5/8"	2-7/16"	\$4.39
219CO1464	7/32"	.2188	3-3/4"	2-1/2"	\$4.69
219CO1564	15/64"	.2344	3-7/8"	2-5/8"	\$5.16
219CO1664	1/4"	.2500	4"	2-3/4"	\$5.62
219CO1764	17/64"	.2656	4-1/8"	2-7/8"	\$6.05
219CO1864	9/32"	.2812	4-1/4"	2-15/16"	\$6.62

PART NUMBER	DRILL SIZE	DEC. EQUIV.	O/A LENGTH	FLUTE LENGTH	PRICE EACH
219CO1964	19/64"	.2969	4-3/8"	3-1/16"	\$7.63
219CO2064	5/16"	.3125	4-1/2"	3-3/16"	\$8.18
219CO2164	21/64"	.3281	4-5/8"	3-5/16"	\$8.98
219CO2264	11/32"	.3438	4-3/4"	3-7/16"	\$10.39
219CO2364	23/64"	.3594	4-7/8"	3-1/2"	\$11.81
219CO2464	3/8"	.3750	5"	3-5/8"	\$12.39
219CO2564	25/64"	.3906	5-1/8"	3-3/4"	\$13.06
219CO2664	13/32"	.4062	5-1/4"	3-7/8"	\$13.95
219CO2764	27/64"	.4219	5-3/8"	3-15/16"	\$14.75
219CO2864	7/16"	.4375	5-1/2"	4-1/16"	\$15.34
219CO2964	29/64"	.4531	5-5/8"	4-3/16"	\$18.31
219CO3064	15/32"	.4688	5-3/4"	4-5/16"	\$18.73
219CO3164	31/64"	.4844	5-7/8"	4-3/8"	\$19.17
219CO3264	1/2"	.5000	6"	4-1/2"	\$19.75

SIZES THROUGH 5/16" ARE PACKAGED 12/ PACK.
SIZES 21/64" → 1/2" ARE PACKAGED 6/ PACK.



135°
SPLIT
POINT

TITANIUM NITRIDE COATED DRILLS HSS

SERIES 255SP FRACTIONAL SIZES

BRIGHT GOLD FINISH

- Jobber Length
- Straight Shank
- Ground Flute
- Suitable for
 - Tool Steel
 - Alloys
 - Stainless Steel
 - Cast Iron
 - Hard To Machine Materials

PART NUMBER	DRILL SIZE	DEC. EQUIV.	O/A LENGTH	FLUTE LENGTH	PRICE EACH
255SP0464	1/16"	.0625	1-7/8"	7/8"	\$2.47
255SP0564	5/64"	.0781	2"	1"	\$2.47
255SP0664	3/32"	.0938	2-1/4"	1-1/4"	\$2.47
255SP0764	7/64"	.1094	2-5/8"	1-1/2"	\$2.47
255SP0864	1/8"	.1250	2-3/4"	1-5/8"	\$2.47
255SP0964	9/64"	.1406	2-7/8"	1-3/4"	\$2.51
255SP1064	5/32"	.1562	3-1/8"	2"	\$2.51
255SP1164	11/64"	.1719	3-1/4"	2-1/8"	\$2.70
255SP1264	3/16"	.1875	3-1/2"	2-5/16"	\$2.76
255SP1364	13/64"	.2031	3-5/8"	2-7/16"	\$4.94
255SP1464	7/32"	.2188	3-3/4"	2-1/2"	\$5.17
255SP1564	15/64"	.2344	3-7/8"	2-5/8"	\$5.23
255SP1664	1/4"	.2500	4"	2-3/4"	\$5.26
255SP1764	17/64"	.2656	4-1/8"	2-7/8"	\$7.88
255SP1864	9/32"	.2812	4-1/4"	2-15/16"	\$8.00

PART NUMBER	DRILL SIZE	DEC. EQUIV.	O/A LENGTH	FLUTE LENGTH	PRICE EACH
255SP1964	19/64"	.2969	4-3/8"	3-1/16"	\$8.47
255SP2064	5/16"	.3125	4-1/2"	3-3/16"	\$8.63
255SP2164	21/64"	.3281	4-5/8"	3-5/16"	\$8.98
255SP2264	11/32"	.3438	4-3/4"	3-7/16"	\$9.28
255SP2364	23/64"	.3594	4-7/8"	3-1/2"	\$12.65
255SP2464	3/8"	.3750	5"	3-5/8"	\$13.14
255SP2564	25/64"	.3906	5-1/8"	3-3/4"	\$15.37
255SP2664	13/32"	.4062	5-1/4"	3-7/8"	\$15.61
255SP2764	27/64"	.4219	5-3/8"	3-15/16"	\$16.20
255SP2864	7/16"	.4375	5-1/2"	4-1/16"	\$16.83
255SP2964	29/64"	.4531	5-5/8"	4-3/16"	\$17.41
255SP3064	15/32"	.4688	5-3/4"	4-5/16"	\$17.90
255SP3164	31/64"	.4844	5-7/8"	4-3/8"	\$18.33
255SP3264	1/2"	.5000	6"	4-1/2"	\$18.54

IMPORTED



TITANIUM NITRIDE & COBALT STEEL JOBBER DRILL SETS AVAILABLE ON PAGE 22 → 23. REDUCED SHANK DRILL BITS AVAILABLE ON PAGE 13.

MAIN OFFICE

INTERNATIONAL TOOL MANUFACTURING
71-08 51ST. AVENUE, WOODSIDE, NY 11377
(718) 446-0711 • (800) 247-5696 • FAX (718) 899-6553



INTERNATIONAL TOOL MANUFACTURING
675-E-PROGRESS CENTER AVE., LAWRENCEVILLE, GA 30043
(770) 962-5454 • (800) 229-1776 • FAX (770) 962-5869

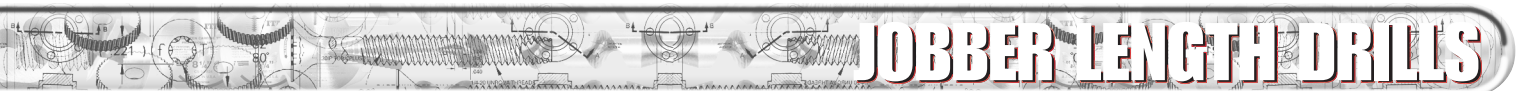

**1/4" SHANK 4" LENGTH
GENERAL PURPOSE HSS**

**SERIES 200L4 FRACTIONAL
TWO TONE FINISH 118° POINT**

PART NUMBER	DRILL SIZE	DEC. EQUIV.	O/A LENGTH	FLUTE LENGTH	PRICE EACH
200L42064	5/16"	.3125	4"	2-3/4"	\$3.65
200L42464	3/8"	.3750	4"	2-3/4"	\$5.08
200L42864	7/16"	.4375	4"	2-3/4"	\$6.51
200L43264	1/2"	.5000	4"	2-3/4"	\$8.07

**1/4" SHANK DRILLS
GENERAL PURPOSE HSS**

**SERIES 200R4 FRACTIONAL
TWO TONE FINISH 118° POINT**

PART NUMBER	DRILL SIZE	DEC. EQUIV.	O/A LENGTH	FLUTE LENGTH	PRICE EACH
200R41764	17/64"	.2656	4-1/8"	2-7/8"	\$3.30
200R41864	9/32"	.2812	4-1/4"	2-15/16"	\$3.95
200R41964	19/64"	.2969	4-3/8"	3-1/16"	\$4.17
200R42064	5/16"	.3125	4-1/2"	3-3/16"	\$4.24
200R42164	21/64"	.3281	4-5/8"	3-5/16"	\$4.59
200R42264	11/32"	.3438	4-3/4"	3-7/16"	\$5.14
200R42364	23/64"	.3594	4-7/8"	3-1/2"	\$5.63
200R42464	3/8"	.3750	5"	3-5/8"	\$5.74
200R42564	25/64"	.3906	5-1/8"	3-3/4"	\$6.11
200R42664	13/32"	.4062	5-1/4"	3-7/8"	\$6.24
200R42764	27/64"	.4219	5-3/8"	3-15/16"	\$6.78
200R42864	7/16"	.4375	5-1/2"	4-1/16"	\$7.18
200R42964	29/64"	.4531	5-5/8"	4-3/16"	\$8.23
200R43064	15/32"	.4688	5-3/4"	4-5/16"	\$8.59
200R43164	31/64"	.4844	5-3/4"	4-3/8"	\$8.73
200R43264	1/2"	.5000	6"	4-1/2"	\$8.83

**3/8" SHANK DRILLS
COBALT STEEL HSS**

**SERIES 219R8 FRACTIONAL
GOLD FINISH 135° POINT**

PART NUMBER	DRILL SIZE	DEC. EQUIV.	O/A LENGTH	FLUTE LENGTH	PRICE EACH
219R82564	25/64"	.3906	5-1/8"	3-3/4"	\$14.81
219R82664	13/32"	.4062	5-1/4"	3-7/8"	\$16.02
219R82764	27/64"	.4219	5-3/8"	3-15/16"	\$17.10
219R82864	7/16"	.4375	5-1/2"	4-1/16"	\$18.44
219R82964	29/64"	.4531	5-5/8"	4-3/16"	\$19.62
219R83064	15/32"	.4688	5-3/4"	4-5/16"	\$21.02
219R83164	31/64"	.4844	5-3/4"	4-3/8"	\$22.33
219R83264	1/2"	.5000	6"	4-1/2"	\$23.54

**3/8" SHANK DRILLS
GENERAL PURPOSE HSS**

**SERIES 200R8 FRACTIONAL
TWO TONE FINISH 118° POINT**

PART NUMBER	DRILL SIZE	DEC. EQUIV.	O/A LENGTH	FLUTE LENGTH	PRICE EACH
200R82564	25/64"	.3906	5-1/8"	3-3/4"	\$6.11
200R82664	13/32"	.4062	5-1/4"	3-7/8"	\$6.24
200R82764	27/64"	.4219	5-3/8"	3-15/16"	\$6.78
200R82864	7/16"	.4375	5-1/2"	4-1/16"	\$7.18
200R82964	29/64"	.4531	5-5/8"	4-3/16"	\$8.23
200R83064	15/32"	.4688	5-3/4"	4-5/16"	\$8.59
200R83164	31/64"	.4844	5-3/4"	4-3/8"	\$8.73
200R83264	1/2"	.5000	6"	4-1/2"	\$8.83

**3/8" SHANK DRILLS
TRITON HEAVY DUTY HSS**

**SERIES 206R8 FRACTIONAL
BLACK OXIDE FINISH 135° POINT**

PART NUMBER	DRILL SIZE	DEC. EQUIV.	O/A LENGTH	FLUTE LENGTH	PRICE EACH
206R82564	25/64"	.3906	5-1/8"	3-3/4"	\$9.83
206R82664	13/32"	.4062	5-1/4"	3-7/8"	\$10.15
206R82764	27/64"	.4219	5-3/8"	3-15/16"	\$10.65
206R82864	7/16"	.4375	5-1/2"	4-1/16"	\$11.44
206R82964	29/64"	.4531	5-5/8"	4-3/16"	\$12.69
206R83064	15/32"	.4688	5-3/4"	4-5/16"	\$13.02
206R83164	31/64"	.4844	5-3/4"	4-3/8"	\$13.05
206R83264	1/2"	.5000	6"	4-1/2"	\$14.04

**3/8" SHANK DRILLS
SUPERBA HEAVY DUTY HSS**

**SERIES 206U8 FRACTIONAL
BLACK OXIDE & GOLD FINISH 135° POINT**

PART NUMBER	DRILL SIZE	DEC. EQUIV.	O/A LENGTH	FLUTE LENGTH	PRICE EACH
206U82564	25/64"	.3906	5-1/8"	3-3/4"	\$10.82
206U82664	13/32"	.4062	5-1/4"	3-7/8"	\$11.16
206U82764	27/64"	.4219	5-3/8"	3-15/16"	\$11.72
206U82864	7/16"	.4375	5-1/2"	4-1/16"	\$12.58
206U82964	29/64"	.4531	5-5/8"	4-3/16"	\$13.96
206U83064	15/32"	.4688	5-3/4"	4-5/16"	\$14.32
206U83164	31/64"	.4844	5-3/4"	4-3/8"	\$14.36
206U83264	1/2"	.5000	6"	4-1/2"	\$15.44



- REDUCED SHANK
- Bright Shank
- Black Flute
- Roll Forged
- M2 High Speed Steel
- Suitable for
 - Cast Iron
 - Steel
 - Other Work Materials

IMPORTED

ALL DRILL BITS THIS PAGE PACKAGED 6 PER PACK



MADE IN THE USA



- REDUCED SHANK
- Ground Flute
- M2 High Speed Steel
- Thicker Web To Provide Extra Strength & Rigidity
- Suitable for
 - Medium Alloyed Materials
 - Stainless Steel

REDUCED SHANK JOBBER DRILL SETS AVAILABLE ON PAGES 24 → 27.

MAIN OFFICE

INTERNATIONAL TOOL MANUFACTURING
71-08 51ST. AVENUE, WOODSIDE, NY 11377
(718) 446-0711 • (800) 247-5696 • FAX (718) 899-6553



INTERNATIONAL TOOL MANUFACTURING
675-E-PROGRESS CENTER AVE., LAWRENCEVILLE, GA 30043
(770) 962-5454 • (800) 229-1776 • FAX (770) 962-5869

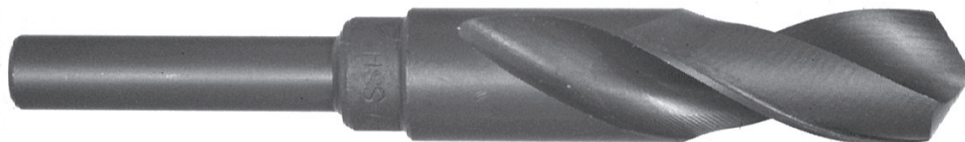
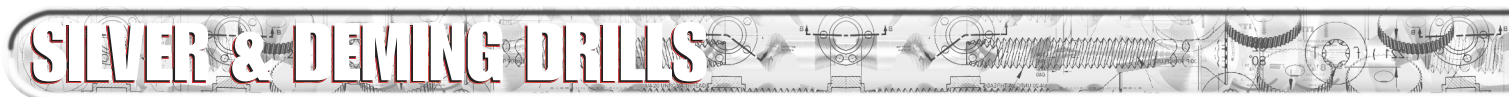

**118°
POINT**

1/2" SHANK 6" LONG SILVER & DEMING HSS

SERIES 201SD

BLACK OXIDE FINISH

- 6" Length
- 1/2" Shank
- M2 High Speed Steel
- Suitable for
 - Cast Iron
 - Steel
 - Steel Forging
 - Other Work Materials

PART NUMBER	DRILL SIZE	DEC. EQUIV.	O/A LENGTH	FLUTE LENGTH	PRICE EACH
201SD3364	33/64"	.5156	6"	2-3/4"	\$13.88
201SD3464	17/32"	.5312	6"	2-3/4"	\$14.11
201SD3564	35/64"	.5469	6"	2-3/4"	\$14.32
201SD3664	9/16"	.5625	6"	2-3/4"	\$14.32
201SD3764	37/64"	.5781	6"	2-3/4"	\$16.03
201SD3864	19/32"	.5938	6"	2-3/4"	\$16.03
201SD3964	39/64"	.6094	6"	2-3/4"	\$16.25
201SD4064	5/8"	.6250	6"	2-3/4"	\$16.25
201SD4164	41/64"	.6406	6"	2-3/4"	\$17.36
201SD4264	21/32"	.6562	6"	2-3/4"	\$17.36
201SD4364	43/64"	.6719	6"	2-3/4"	\$18.12
201SD4464	11/16"	.6875	6"	2-3/4"	\$18.12
201SD4564	45/64"	.7031	6"	2-3/4"	\$19.07
201SD4664	23/32"	.7188	6"	2-3/4"	\$19.07
201SD4764	47/64"	.7344	6"	2-3/4"	\$19.65
201SD4864	3/4"	.7500	6"	2-3/4"	\$19.65
201SD4964	49/64"	.7656	6"	2-3/4"	\$21.08
201SD5064	25/32"	.7812	6"	2-3/4"	\$21.08
201SD5164	51/64"	.7969	6"	2-3/4"	\$21.44
201SD5264	13/16"	.8125	6"	2-3/4"	\$21.44

PART NUMBER	DRILL SIZE	DEC. EQUIV.	O/A LENGTH	FLUTE LENGTH	PRICE EACH
201SD5364	53/64"	.8281	6"	2-3/4"	\$22.39
201SD5464	27/32"	.8438	6"	2-3/4"	\$22.60
201SD5564	55/64"	.8594	6"	2-3/4"	\$23.12
201SD5664	7/8"	.8750	6"	2-3/4"	\$23.12
201SD5764	57/64"	.8906	6"	2-3/4"	\$25.49
201SD5864	29/32"	.9062	6"	2-3/4"	\$25.49
201SD5964	59/64"	.9219	6"	2-3/4"	\$25.75
201SD6064	15/16"	.9375	6"	2-3/4"	\$25.75
201SD6164	61/64"	.9531	6"	2-3/4"	\$27.72
201SD6264	31/32"	.9688	6"	2-3/4"	\$27.72
201SD6364	63/64"	.9844	6"	2-3/4"	\$29.56
201SD6464	1"	1.0000	6"	2-3/4"	\$29.56
201SD6864	1-1/16"	1.0625	6"	2-3/4"	\$43.92
201SD7264	1-1/8"	1.1250	6"	2-3/4"	\$46.06
201SD7664	1-3/16"	1.1875	6"	2-3/4"	\$54.94
201SD8064	1-1/4"	1.2500	6"	2-3/4"	\$63.62
201SD8464	1-5/16"	1.3125	6"	2-3/4"	\$66.81
201SD8864	1-3/8"	1.3750	6"	2-3/4"	\$72.59
201SD9664	1-1/2"	1.5000	6"	2-3/4"	\$80.99

IMPORTED



BARCODED

ALL SILVER & DEMING DRILL BITS ARE SOLD INDIVIDUALLY. 1 PER TUBED.

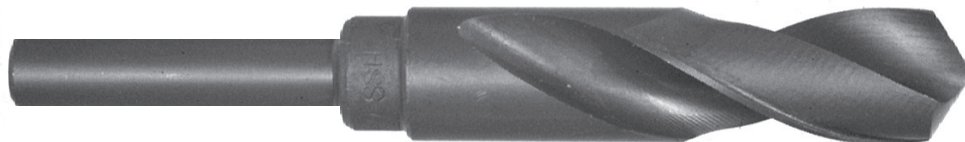

**118°
POINT**

3/8" SHANK 6" LONG SILVER & DEMING HSS

SERIES 201R8

BLACK OXIDE FINISH

- 6" Length
- 3/8" Shank
- M2 High Speed Steel
- Suitable for
 - Cast Iron
 - Steel
 - Steel Forging
 - Other Work Materials

PART NUMBER	DRILL SIZE	DEC. EQUIV.	O/A LENGTH	FLUTE LENGTH	PRICE EACH
201R83364	33/64"	.5156	6"	2-3/4"	\$11.54
201R83464	17/32"	.5312	6"	2-3/4"	\$12.67
201R83564	35/64"	.5469	6"	2-3/4"	\$16.58
201R83664	9/16"	.5625	6"	2-3/4"	\$16.58
201R83764	37/64"	.5781	6"	2-3/4"	\$19.29
201R83864	19/32"	.5938	6"	2-3/4"	\$18.29
201R83964	39/64"	.6094	6"	2-3/4"	\$18.29
201R84064	5/8"	.6250	6"	2-3/4"	\$18.29

PART NUMBER	DRILL SIZE	DEC. EQUIV.	O/A LENGTH	FLUTE LENGTH	PRICE EACH
201R84164	41/64"	.6406	6"	2-3/4"	\$19.90
201R84264	21/32"	.6562	6"	2-3/4"	\$19.90
201R84364	43/64"	.6719	6"	2-3/4"	\$19.90
201R84464	11/16"	.6875	6"	2-3/4"	\$19.90
201R84564	45/64"	.7031	6"	2-3/4"	\$20.68
201R84664	23/32"	.7188	6"	2-3/4"	\$20.68
201R84764	47/64"	.7344	6"	2-3/4"	\$21.71
201R84864	3/4"	.7500	6"	2-3/4"	\$21.71

IMPORTED



1/2" SHANK SILVER & DEMING DRILL SET AVAILABLE ON PAGE 23.

MAIN OFFICE

INTERNATIONAL TOOL MANUFACTURING
71-08 51ST. AVENUE, WOODSIDE, NY 11377
(718) 446-0711 • (800) 247-5696 • FAX (718) 899-6553



INTERNATIONAL TOOL MANUFACTURING
675-E-PROGRESS CENTER AVE., LAWRENCEVILLE, GA 30043
(770) 962-5454 • (800) 229-1776 • FAX (770) 962-5869

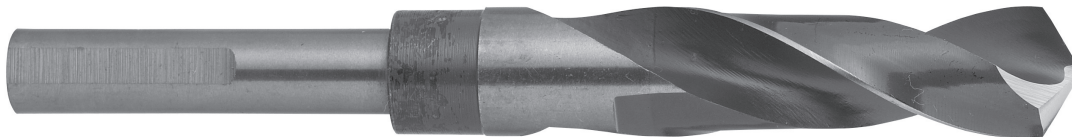
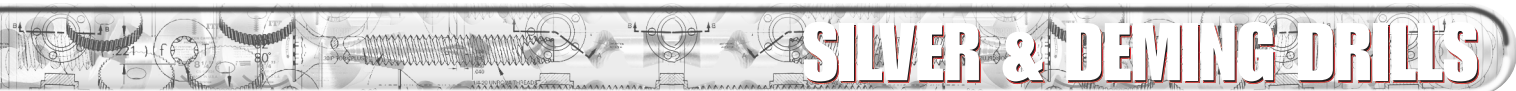

MADE IN THE USA

1/2" SHANK 6" LONG SUPERBA SILVER & DEMING HEAVY DUTY

118° SPLIT POINT



SERIES 201US

BLACK OXIDE & GOLD FINISH

PART NUMBER	DRILL SIZE	DEC. EQUIV.	O/A LENGTH	FLUTE LENGTH	PRICE EACH
201US3364	33/64"	.5156	6"	2-3/4"	\$17.24
201US3464	17/32"	.5312	6"	2-3/4"	\$17.24
201US3564	35/64"	.5469	6"	2-3/4"	\$17.92
201US3664	9/16"	.5625	6"	2-3/4"	\$17.92
201US3764	37/64"	.5781	6"	2-3/4"	\$18.44
201US3864	19/32"	.5938	6"	2-3/4"	\$18.44
201US3964	39/64"	.6094	6"	2-3/4"	\$18.72
201US4064	5/8"	.6250	6"	2-3/4"	\$18.72
201US4164	41/64"	.6406	6"	2-3/4"	\$19.64
201US4264	21/32"	.6562	6"	2-3/4"	\$19.64
201US4364	43/64"	.6719	6"	2-3/4"	\$20.32
201US4464	11/16"	.6875	6"	2-3/4"	\$20.32
201US4564	45/64"	.7031	6"	2-3/4"	\$21.36
201US4664	23/32"	.7188	6"	2-3/4"	\$21.36
201US4764	47/64"	.7344	6"	2-3/4"	\$30.36
201US4864	3/4"	.7500	6"	2-3/4"	\$30.36

PART NUMBER	DRILL SIZE	DEC. EQUIV.	O/A LENGTH	FLUTE LENGTH	PRICE EACH
201US4964	49/64"	.7656	6"	2-3/4"	\$31.32
201US5064	25/32"	.7812	6"	2-3/4"	\$31.32
201US5164	51/64"	.7969	6"	2-3/4"	\$32.04
201US5264	13/16"	.8125	6"	2-3/4"	\$32.04
201US5364	53/64"	.8281	6"	2-3/4"	\$33.04
201US5464	27/32"	.8438	6"	2-3/4"	\$33.04
201US5564	55/64"	.8594	6"	2-3/4"	\$35.40
201US5664	7/8"	.8750	6"	2-3/4"	\$35.40
201US5764	57/64"	.8906	6"	2-3/4"	\$35.90
201US5864	29/32"	.9062	6"	2-3/4"	\$35.90
201US5964	59/64"	.9219	6"	2-3/4"	\$37.60
201US6064	15/16"	.9375	6"	2-3/4"	\$37.60
201US6164	61/64"	.9531	6"	2-3/4"	\$39.88
201US6264	31/32"	.9688	6"	2-3/4"	\$39.88
201US6364	63/64"	.9844	6"	2-3/4"	\$42.04
201US6464	1"	1.0000	6"	2-3/4"	\$42.04

- 6" Length
- 3-Flat Round 1/2" Shank
- 118° Split Point
- M2 High Speed Steel
- Suitable for
 - Cast Iron
 - Stainless Steel
 - Steel Forging
 - Tougher Work Materials

MADE IN U.S.A.



BARCODED

ALL SILVER & DEMING DRILL BITS ARE SOLD INDIVIDUALLY. 1 PER TUBED.

↓ Cobalt is best suited for for heat treated materials and stainless steels. ↓

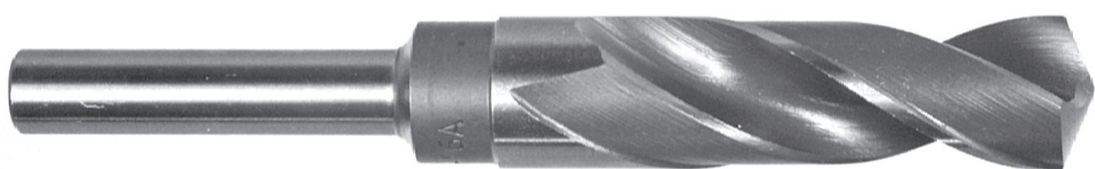

135° SPLIT POINT



1/2" SHANK 6" LONG COBALT SILVER & DEMING HEAVYDUTY

SERIES 201CO

GOLD FINISH

PART NUMBER	DRILL SIZE	DEC. EQUIV.	O/A LENGTH	FLUTE LENGTH	PRICE EACH
201CO3464	17/32"	.5312	6"	2-3/4"	\$36.19
201CO3664	9/16"	.5625	6"	2-3/4"	\$41.71
201CO3864	19/32"	.5938	6"	2-3/4"	\$44.16
201CO4064	5/8"	.6250	6"	2-3/4"	\$46.62
201CO4264	21/32"	.6562	6"	2-3/4"	\$49.69
201CO4464	11/16"	.6875	6"	2-3/4"	\$52.13
201CO4664	23/32"	.7188	6"	2-3/4"	\$54.59
201CO4864	3/4"	.7500	6"	2-3/4"	\$57.05
201CO5064	25/32"	.7812	6"	2-3/4"	\$59.49
201CO5264	13/16"	.8125	6"	2-3/4"	\$63.79
201CO5464	27/32"	.8438	6"	2-3/4"	\$66.24
201CO5664	7/8"	.8750	6"	2-3/4"	\$68.70

PART NUMBER	DRILL SIZE	DEC. EQUIV.	O/A LENGTH	FLUTE LENGTH	PRICE EACH
201CO5864	29/32"	.9062	6"	2-3/4"	\$72.38
201CO6064	15/16"	.9375	6"	2-3/4"	\$77.28
201CO6264	31/32"	.9688	6"	2-3/4"	\$87.98
201CO6464	1"	1.0000	6"	2-3/4"	\$90.78
201CO6864	1-1/16"	1.0625	6"	2-3/4"	\$106.72
201CO7264	1-1/8"	1.1250	6"	2-3/4"	\$121.45
201CO7664	1-3/16"	1.1875	6"	2-3/4"	\$134.95
201CO8064	1-1/4"	1.2500	6"	2-3/4"	\$145.98
201CO8404	1-5/16"	1.3125	6"	2-3/4"	\$158.25
201CO8864	1-3/8"	1.3750	6"	2-3/4"	\$169.29
201CO9664	1-1/2"	1.5000	6"	2-3/4"	\$182.79

- 6" Length
- Round 1/2" Shank
- 135° Split Point
- M42 High Speed Steel
- Suitable for
 - Heat Treated Material
 - Stainless Steel
 - High Temperature Alloys
 - Difficult Work Materials

IMPORTED

MAIN OFFICE

INTERNATIONAL TOOL MANUFACTURING
71-08 51ST. AVENUE, WOODSIDE, NY 11377
(718) 446-0711 • (800) 247-5696 • FAX (718) 899-6553



INTERNATIONAL TOOL MANUFACTURING
675-E-PROGRESS CENTER AVE., LAWRENCEVILLE, GA 30043
(770) 962-5454 • (800) 229-1776 • FAX (770) 962-5869

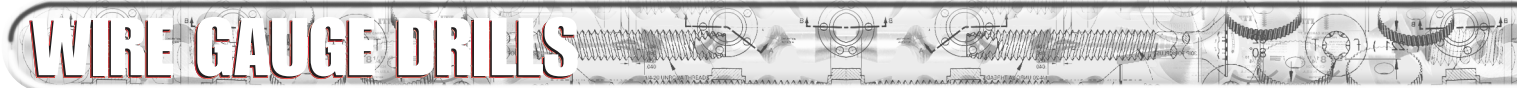

**118°
POINT**

ALL WIRE GAUGE DRILL BITS ARE PACKAGED 12 PER PACK.



- Wire Gauge
- Straight Shank
- Black Finish
- Roll Forged
- M2 High Speed Steel
- Suitable for
 - Cast Iron
 - Steel
 - Steel Forging
 - Other Work Materials

IMPORTED

GENERAL PURPOSE DRILLS HSS

SERIES 203HS WIRE GAUGE SIZES

BLACK OXIDE FINISH

PART NUMBER	DRILL SIZE	DEC. EQUIV.	O/A LENGTH	FLUTE LENGTH	PRICE EACH
203HS0001	1	.2280	3-7/8"	2-5/8"	\$1.59
203HS0002	2	.2210	3-7/8"	2-5/8"	\$1.59
203HS0003	3	.2130	3-3/4"	2-1/2"	\$1.72
203HS0004	4	.2090	3-3/4"	2-1/2"	\$1.72
203HS0005	5	.2055	3-3/4"	2-1/2"	\$1.72
203HS0006	6	.2040	3-3/4"	2-1/2"	\$1.72
203HS0007	7	.2010	3-5/8"	2-7/16"	\$1.72
203HS0008	8	.1990	3-5/8"	2-7/16"	\$1.72
203HS0009	9	.1960	3-5/8"	2-7/16"	\$1.72
203HS0010	10	.1935	3-5/8"	2-7/16"	\$1.72
203HS0011	11	.1910	3-1/2"	2-5/16"	\$1.63
203HS0012	12	.1890	3-1/2"	2-5/16"	\$1.63
203HS0013	13	.1850	3-1/2"	2-5/16"	\$1.63
203HS0014	14	.1820	3-3/8"	2-3/16"	\$1.63
203HS0015	15	.1800	3-3/8"	2-3/16"	\$1.63
203HS0016	16	.1770	3-3/8"	2-3/16"	\$1.63
203HS0017	17	.1730	3-3/8"	2-3/16"	\$1.63
203HS0018	18	.1695	3-1/4"	2-1/8"	\$1.63
203HS0019	19	.1660	3-1/4"	2-1/8"	\$1.63
203HS0020	20	.1610	3-1/4"	2-1/8"	\$1.46
203HS0021	21	.1590	3-1/4"	2-1/8"	\$1.46
203HS0022	22	.1570	3-1/8"	2"	\$1.53
203HS0023	23	.1540	3-1/8"	2"	\$1.53
203HS0024	24	.1520	3-1/8"	2"	\$1.09
203HS0025	25	.1495	3"	1-7/8"	\$1.09
203HS0026	26	.1470	3"	1-7/8"	\$1.09
203HS0027	27	.1440	3"	1-7/8"	\$1.09
203HS0028	28	.1405	2-7/8"	1-3/4"	\$1.09
203HS0029	29	.1360	2-7/8"	1-3/4"	\$0.91
203HS0030	30	.1285	2-3/4"	1-5/8"	\$0.91
203HS0031	31	.1200	2-3/4"	1-5/8"	\$0.91
203HS0032	32	.1160	2-3/4"	1-5/8"	\$0.91
203HS0033	33	.1130	2-5/8"	1-1/2"	\$0.91
203HS0034	34	.1110	2-5/8"	1-1/2"	\$0.91
203HS0035	35	.1100	2-5/8"	1-1/2"	\$0.91
203HS0036	36	.1065	2-1/2"	1-7/16"	\$0.91
203HS0037	37	.1040	2-1/2"	1-7/16"	\$0.91
203HS0038	38	.1015	2-1/2"	1-7/16"	\$0.91
203HS0039	39	.0995	2-3/8"	1-3/8"	\$0.91
203HS0040	40	.0980	2-3/8"	1-3/8"	\$0.91

PART NUMBER	DRILL SIZE	DEC. EQUIV.	O/A LENGTH	FLUTE LENGTH	PRICE EACH
203HS0041	41	.0960	2-3/8"	1-3/8"	\$0.91
203HS0042	42	.0935	2-1/4"	1-1/4"	\$0.91
203HS0043	43	.0890	2-1/4"	1-1/4"	\$0.91
203HS0044	44	.0860	2-1/8"	1-1/8"	\$0.91
203HS0045	45	.0820	2-1/8"	1-1/8"	\$0.91
203HS0046	46	.0810	2-1/8"	1-1/8"	\$0.91
203HS0047	47	.0785	2"	1"	\$0.91
203HS0048	48	.0760	2"	1"	\$0.91
203HS0049	49	.0730	2"	1"	\$0.91
203HS0050	50	.0700	2"	1"	\$0.91
203HS0051	51	.0670	2"	1"	\$0.91
203HS0052	52	.0635	1-7/8"	7/8"	\$0.91
203HS0053	53	.0595	1-7/8"	7/8"	\$0.91
203HS0054	54	.0550	1-7/8"	7/8"	\$0.91
203HS0055	55	.0520	1-7/8"	7/8"	\$0.91
203HS0056	56	.0465	1-3/4"	3/4"	\$0.91
203HS0057	57	.0430	1-3/4"	3/4"	\$0.91
203HS0058	58	.0420	1-5/8"	11/16"	\$0.91
203HS0059	59	.0410	1-5/8"	11/16"	\$0.91
203HS0060	60	.0400	1-5/8"	11/16"	\$0.91
203HS0061	61	.0390	1-5/8"	11/16"	\$1.50
203HS0062	62	.0380	1-1/2"	5/8"	\$1.50
203HS0063	63	.0370	1-1/2"	5/8"	\$1.50
203HS0064	64	.0360	1-1/2"	5/8"	\$1.50
203HS0065	65	.0350	1-1/2"	5/8"	\$1.50
203HS0066	66	.0330	1-3/8"	1/2"	\$1.50
203HS0067	67	.0320	1-3/8"	1/2"	\$1.50
203HS0068	68	.0310	1-3/8"	1/2"	\$1.50
203HS0069	69	.0292	1-3/8"	1/2"	\$1.50
203HS0070	70	.0280	1-1/4"	3/8"	\$1.50
203HS0071	71	.0260	1-1/4"	3/8"	\$1.50
203HS0072	72	.0250	1-1/8"	5/16"	\$1.50
203HS0073	73	.0240	1-1/8"	5/16"	\$1.50
203HS0074	74	.0225	1"	1/4"	\$1.50
203HS0075	75	.0210	1"	1/4"	\$1.50
203HS0076	76	.0200	7/8"	3/16"	\$1.50
203HS0077	77	.0180	7/8"	3/16"	\$1.50
203HS0078	78	.0160	7/8"	3/16"	\$1.50
203HS0079	79	.0145	3/4"	3/16"	\$1.50
203HS0080	80	.0135	3/4"	3/16"	\$1.50



BLACK FINISH WIRE GAUGE DRILL SETS ARE AVAILABLE ON PAGE 23.

MAIN OFFICE

INTERNATIONAL TOOL MANUFACTURING
71-08 51ST. AVENUE, WOODSIDE, NY 11377
(718) 446-0711 • (800) 247-5696 • FAX (718) 899-6553



INTERNATIONAL TOOL MANUFACTURING
675-E-PROGRESS CENTER AVE., LAWRENCEVILLE, GA 30043
(770) 962-5454 • (800) 229-1776 • FAX (770) 962-5869

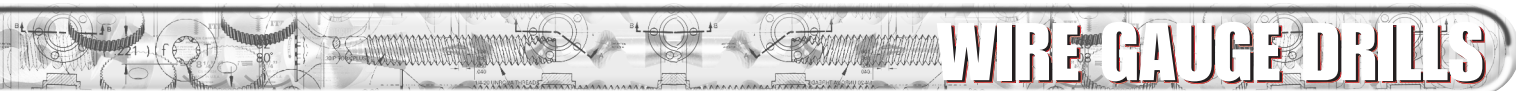

TRITON HEAVY DUTY SUPER HSS



SERIES 207SP WIRE GAUGE SIZES

BLACK OXIDE FINISH

PART NUMBER	DRILL SIZE	DEC. EQUIV.	O/A LENGTH	FLUTE LENGTH	PRICE EACH
207SP0001	1	.2280	3-7/8"	2-5/8"	\$2.21
207SP0002	2	.2210	3-7/8"	2-5/8"	\$2.21
207SP0003	3	.2130	3-3/4"	2-1/2"	\$2.21
207SP0004	4	.2090	3-3/4"	2-1/2"	\$2.21
207SP0005	5	.2055	3-3/4"	2-1/2"	\$2.21
207SP0006	6	.2040	3-3/4"	2-1/2"	\$2.21
207SP0007	7	.2010	3-5/8"	2-7/16"	\$2.05
207SP0008	8	.1990	3-5/8"	2-7/16"	\$2.05
207SP0009	9	.1960	3-5/8"	2-7/16"	\$2.05
207SP0010	10	.1935	3-5/8"	2-7/16"	\$2.05
207SP0011	11	.1910	3-1/2"	2-5/16"	\$2.05
207SP0012	12	.1890	3-1/2"	2-5/16"	\$2.05
207SP0013	13	.1850	3-1/2"	2-5/16"	\$1.61
207SP0014	14	.1820	3-3/8"	2-3/16"	\$1.61
207SP0015	15	.1800	3-3/8"	2-3/16"	\$1.61
207SP0016	16	.1770	3-3/8"	2-3/16"	\$1.61
207SP0017	17	.1730	3-3/8"	2-3/16"	\$1.61
207SP0018	18	.1695	3-1/4"	2-1/8"	\$1.61
207SP0019	19	.1660	3-1/4"	2-1/8"	\$1.61
207SP0020	20	.1610	3-1/4"	2-1/8"	\$1.61
207SP0021	21	.1590	3-1/4"	2-1/8"	\$1.61
207SP0022	22	.1570	3-1/8"	2"	\$1.61
207SP0023	23	.1540	3-1/8"	2"	\$1.39
207SP0024	24	.1520	3-1/8"	2"	\$1.39
207SP0025	25	.1495	3"	1-7/8"	\$1.39
207SP0026	26	.1470	3"	1-7/8"	\$1.39
207SP0027	27	.1440	3"	1-7/8"	\$1.39
207SP0028	28	.1405	2-7/8"	1-3/4"	\$1.16
207SP0029	29	.1360	2-7/8"	1-3/4"	\$1.16
207SP0030	30	.1285	2-3/4"	1-5/8"	\$1.16

PART NUMBER	DRILL SIZE	DEC. EQUIV.	O/A LENGTH	FLUTE LENGTH	PRICE EACH
207SP0031	31	.1200	2-3/4"	1-5/8"	\$1.16
207SP0032	32	.1160	2-3/4"	1-5/8"	\$1.10
207SP0033	33	.1130	2-5/8"	1-1/2"	\$1.10
207SP0034	34	.1110	2-5/8"	1-1/2"	\$1.10
207SP0035	35	.1100	2-5/8"	1-1/2"	\$1.10
207SP0036	36	.1065	2-1/2"	1-7/16"	\$1.10
207SP0037	37	.1040	2-1/2"	1-7/16"	\$1.10
207SP0038	38	.1015	2-1/2"	1-7/16"	\$1.10
207SP0039	39	.0995	2-3/8"	1-3/8"	\$1.10
207SP0040	40	.0980	2-3/8"	1-3/8"	\$1.10
207SP0041	41	.0960	2-3/8"	1-3/8"	\$0.94
207SP0042	42	.0935	2-1/4"	1-1/4"	\$0.94
207SP0043	43	.0890	2-1/4"	1-1/4"	\$0.94
207SP0044	44	.0860	2-1/8"	1-1/8"	\$0.94
207SP0045	45	.0820	2-1/8"	1-1/8"	\$0.94
207SP0046	46	.0810	2-1/8"	1-1/8"	\$0.94
207SP0047	47	.0785	2"	1"	\$0.94
207SP0048	48	.0760	2"	1"	\$0.94
207SP0049	49	.0730	2"	1"	\$0.94
207SP0050	50	.0700	2"	1"	\$0.94
207SP0051	51	.0670	2"	1"	\$0.94
207SP0052	52	.0635	1-7/8"	7/8"	\$0.94
207SP0053	53	.0595	1-7/8"	7/8"	\$0.94
207SP0054	54	.0550	1-7/8"	7/8"	\$0.94
207SP0055	55	.0520	1-7/8"	7/8"	\$0.94
207SP0056	56	.0465	1-3/4"	3/4"	\$0.94
207SP0057	57	.0430	1-3/4"	3/4"	\$0.94
207SP0058	58	.0420	1-5/8"	11/16"	\$0.94
207SP0059	59	.0410	1-5/8"	11/16"	\$0.94
207SP0060	60	.0400	1-5/8"	11/16"	\$0.94

ALL WIRE GAUGE DRILL BITS ARE PACKAGED 12 PER PACK.



- Wire Gauge
- Straight Shank
- Black Shank
- Black Flute
- Ground Flute
- M2 High Speed Steel
- Suitable for
 - Cast Iron
 - Steel
 - Steel Forging
 - Other Work Materials

i NOTE: SIZES 40 → 60 HAVE NO SPLIT POINT.
135° SPLIT POINT BLACK FINISH WIRE GAUGE DRILL SETS ARE AVAILABLE ON PAGE 23.

COBALT STEEL DRILLS HSS

SERIES 220CO WIRE GAUGE SIZES

GOLD FINISH

PART NUMBER	DRILL SIZE	PRICE EACH
220CO0001 To 220CO0006	No. 1 To No. 6	\$5.06
220CO0007 To 220CO0018	No. 7 To No. 18	\$3.84
220CO0019 To 220CO0029	No. 19 To No. 29	\$2.85
220CO0030 To 220CO0060	No. 30 To No. 60	\$2.44

- Series 220CO Same as Above Except:
 - M42 Cobalt
 - Gold Finish
 - Made In USA

MAIN OFFICE

INTERNATIONAL TOOL MANUFACTURING
71-08 51ST. AVENUE, WOODSIDE, NY 11377
(718) 446-0711 • (800) 247-5696 • FAX (718) 899-6553



INTERNATIONAL TOOL MANUFACTURING
675-E-PROGRESS CENTER AVE., LAWRENCEVILLE, GA 30043
(770) 962-5454 • (800) 229-1776 • FAX (770) 962-5869

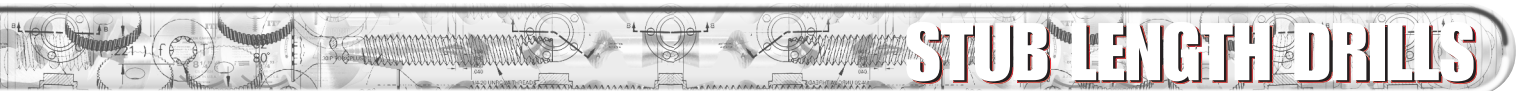

**TRITON WIRE GAUGE
HEAVY DUTY DRILLS HSS**

**SERIES 210SM STUB LENGTH
BLACK OXIDE FINISH 135° SPLIT POINT**

PART NUMBER	DRILL SIZE	DEC. EQUIV.	O/A LENGTH	FLUTE LENGTH	PRICE EACH
210SM0001	1	.2280	2-7/16"	1-15/16"	\$2.23
210SM0002	2	.2210	2-7/16"	1-15/16"	\$2.23
210SM0003	3	.2130	2-3/8"	1-1/4"	\$2.23
210SM0004	4	.2090	2-3/8"	1-1/4"	\$2.23
210SM0005	5	.2055	2-3/8"	1-1/4"	\$2.23
210SM0006	6	.2040	2-3/8"	1-1/4"	\$2.23
210SM0007	7	.2010	2-1/4"	1-3/16"	\$1.79
210SM0008	8	.1990	2-1/4"	1-3/16"	\$1.79
210SM0009	9	.1960	2-1/4"	1-3/16"	\$1.79
210SM0010	10	.1935	2-1/4"	1-3/16"	\$1.79
210SM0011	11	.1910	2-1/4"	1-3/16"	\$1.79
210SM0012	12	.1890	2-1/4"	1-3/16"	\$1.79
210SM0013	13	.1850	2-3/16"	1-1/8"	\$1.62
210SM0014	14	.1820	2-3/16"	1-1/8"	\$1.62
210SM0015	15	.1800	2-3/16"	1-1/8"	\$1.62
210SM0016	16	.1770	2-3/16"	1-1/8"	\$1.62
210SM0017	17	.1730	2-3/16"	1-1/8"	\$1.62
210SM0018	18	.1695	2-1/8"	1-1/16"	\$1.41
210SM0019	19	.1660	2-1/8"	1-1/16"	\$1.41
210SM0020	20	.1610	2-1/8"	1-1/16"	\$1.41
210SM0021	21	.1590	2-1/8"	1-1/16"	\$1.29
210SM0022	22	.1570	2-1/8"	1-1/16"	\$1.29
210SM0023	23	.1540	2-1/16"	1"	\$1.29
210SM0024	24	.1520	2-1/16"	1"	\$1.29
210SM0025	25	.1495	2-1/16"	1"	\$1.29
210SM0026	26	.1470	2-1/16"	1"	\$1.29
210SM0027	27	.1440	2-1/16"	1"	\$1.29
210SM0028	28	.1405	1-15/16"	15/16"	\$1.10
210SM0029	29	.1360	1-15/16"	15/16"	\$1.10
210SM0030	30	.1285	1-15/16"	15/16"	\$1.10
210SM0031	31	.1200	1-7/8"	7/8"	\$1.10
210SM0032	32	.1160	1-7/8"	7/8"	\$1.10
210SM0033	33	.1130	1-7/8"	7/8"	\$1.10
210SM0034	34	.1110	1-7/8"	7/8"	\$1.10
210SM0035	35	.1100	1-7/8"	7/8"	\$1.10
210SM0036	36	.1065	1-13/16"	13/16"	\$1.10
210SM0037	37	.1040	1-13/16"	13/16"	\$1.10
210SM0038	38	.1015	1-13/16"	13/16"	\$1.10
210SM0039	39	.0995	1-13/16"	13/16"	\$1.10
210SM0040	40	.0980	1-13/16"	13/16"	\$1.10

**TRITON FRACTIONAL
HEAVY DUTY DRILLS HSS**

**SERIES 209SM STUB LENGTH
BLACK OXIDE FINISH 135° SPLIT POINT**

PART NUMBER	DRILL SIZE	DEC. EQUIV.	O/A LENGTH	FLUTE LENGTH	PRICE EACH
209SM0464	1/16" *	.0625	1-5/8"	5/8"	\$1.10
209SM0564	5/64" *	.0781	1-11/16"	11/16"	\$1.10
209SM0664	3/32"	.0938	1-3/4"	3/4"	\$1.10
209SM0764	7/64"	.1094	1-13/16"	13/16"	\$1.10
209SM0864	1/8"	.1250	1-7/8"	7/8"	\$1.10
209SM0964	9/64"	.1406	1-15/16"	15/16"	\$1.25
209SM1064	5/32"	.1562	2-1/16"	1"	\$1.25
209SM1164	11/64"	.1719	2-1/8"	1-1/16"	\$1.60
209SM1264	3/16"	.1875	2-3/16"	1-1/8"	\$1.44
209SM1364	13/64"	.2031	2-1/4"	1-3/16"	\$1.57
209SM1464	7/32"	.2188	2-3/8"	1-1/4"	\$1.81
209SM1564	15/64"	.2344	2-7/16"	1-5/16"	\$3.01
209SM1664	1/4"	.2500	2-1/2"	1-3/8"	\$2.37
209SM1764	17/64"	.2656	2-5/8"	1-7/16"	\$2.68
209SM1864	9/32"	.2812	2-11/16"	1-1/2"	\$3.22
209SM1964	19/64"	.2969	2-3/4"	1-9/16"	\$3.37
209SM2064	5/16"	.3125	2-13/16"	1-5/8"	\$3.51
209SM2164	21/64"	.3281	2-15/16"	1-11/16"	\$4.11
209SM2264	11/32"	.3438	3"	1-11/16"	\$4.35
209SM2364	23/64"	.3594	3-1/16"	1-3/4"	\$5.06
209SM2464	3/8"	.3750	3-1/8"	1-13/16"	\$5.06
209SM2564	25/64"	.3906	3-1/4"	1-7/8"	\$6.01
209SM2664	13/32"	.4062	3-5/16"	1-15/16"	\$6.10
209SM2764	27/64"	.4219	3-3/8"	2"	\$6.72
209SM2864	7/16"	.4375	3-7/16"	2-1/16"	\$6.81
209SM2964	29/64"	.4531	3-9/16"	2-1/8"	\$8.00
209SM3064	15/32"	.4688	3-5/8"	2-1/8"	\$8.12
209SM3164	31/64"	.4844	3-11/16"	2-3/16"	\$8.60
209SM3264	1/2"	.5000	3-3/4"	2-1/4"	\$8.60

* No Split Point



1/8" & #30 Double End Also Available in BLACK.

211DE0864-B	1/8"				\$1.14
211DE0030-B	#30				\$1.14



- Heavy Duty
- M2 HSS
- Black Oxide Finish
- Short Flute For Exceptional Strength
- Suitable For:
 - Stainless Steel
 - Medium Alloy Steel
 - Sheet Metal
 - All Types of Automotive Working

SIZES THROUGH 5/16" ARE PACKAGED 12/ PACK. SIZES 21/64" → 1/2" ARE PACKAGED 6/ PACK. SERIES 210SM PACKAGED 12/ PACK. SERIES 211DE PACKAGED 12/ PACK.

DOUBLE ENDED HEAVY DUTY DRILLS SUPER HSS

SERIES 211DE STUB FLUTED FRACT. & WIRE SIZE

PART NUMBER	DRILL SIZE	DEC. EQUIV.	O/A LENGTH	FLUTE LENGTH	PRICE EACH
211DE0764	7/64"	.1094	1-7/8"	1/2"	\$1.06
211DE0864	1/8"	.1250	2"	1/2"	\$1.14
211DE0964	9/64"	.1406	2"	1/2"	\$1.24
211DE1064	5/32"	.1562	2-1/16"	1/2"	\$1.38

BRIGHT FINISH

PART NUMBER	DRILL SIZE	DEC. EQUIV.	O/A LENGTH	FLUTE LENGTH	PRICE EACH
211DE1264	3/16"	.1875	2-3/16"	1/2"	\$1.89
211DE1464	7/32"	.2188	2-3/8"	1/2"	\$2.72
211DE1664	1/4"	.2500	2-1/2"	1/2"	\$2.98
211DE0030	#30	.1285	2"	1/2"	\$1.20



- Heavy Duty
- M2 HSS
- Bright Finish
- Automotive Use

MAIN OFFICE

INTERNATIONAL TOOL MANUFACTURING
71-08 51ST. AVENUE, WOODSIDE, NY 11377
(718) 446-0711 • (800) 247-5696 • FAX (718) 899-6553



INTERNATIONAL TOOL MANUFACTURING
675-E-PROGRESS CENTER AVE., LAWRENCEVILLE, GA 30043
(770) 962-5454 • (800) 229-1776 • FAX (770) 962-5869

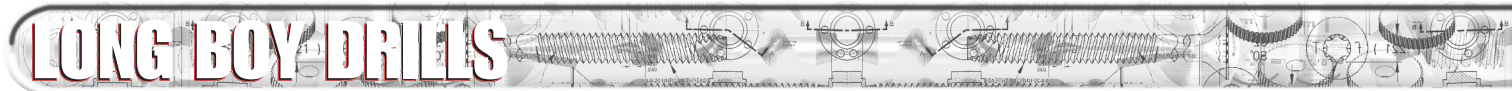

**118°
POINT**



LONG BOY

- Straight Shank To 1/2"
- 1/2" Reduced Shank For Sizes Above 1/2"
- M2 High Speed Steel
- Individually Pouched
- Sharp Cutting Edge To Drill In Many Different Materials:
 - Mild Steel
 - Cast Iron
 - Aluminum
 - Wood
- Imported

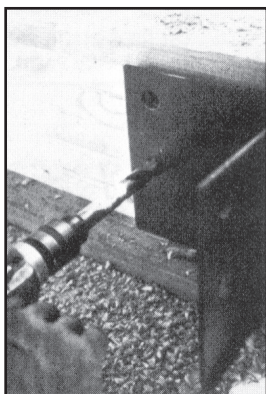

- ⊙ Precision point angle for effective penetration through steel and wood.
- ⊙ Extra length flute with continuous cutting edges for drilling deep holes and fast chip removal.
- ⊙ Reduced shank fits all drill motors with 1/2" chucks.
- ⊙ Non-slip grips prevent the bit from spinning in the chuck.

**12" LONG LONG BOY
GENERAL PURPOSE DRILLS HSS**

SERIES 216HS 118° POINT

PART NUMBER	DRILL SIZE	DEC. EQUIV.	O/A LENGTH	FLUTE LENGTH	PRICE EACH
216HS1264	3/16"	.1875	12"	9"	\$12.37
216HS1464	7/32"	.2188	12"	9"	\$13.19
216HS1664	1/4"	.2500	12"	9"	\$13.19
216HS1864	9/32"	.2812	12"	9"	\$14.52
216HS2064	5/16"	.3125	12"	9"	\$15.52
216HS2264	11/32"	.3438	12"	9"	\$16.45
216HS2464	3/8"	.3750	12"	9"	\$17.99
216HS2664	13/32"	.4062	12"	9"	\$19.13
216HS2864	7/16"	.4375	12"	9"	\$26.06
216HS3064	15/32"	.4688	12"	9"	\$27.30
216HS3264	1/2"	.5000	12"	9"	\$28.54
218HS3664	9/16"	.5625	12"	9"	\$48.04
218HS4064	5/8"	.6250	12"	9"	\$53.59
218HS4464	11/16"	.6875	12"	9"	\$62.12
218HS4864	3/4"	.7500	12"	9"	\$78.06
218HS5664	7/8"	.8750	12"	9"	\$92.97
218HS6064	15/16"	.9375	12"	9"	\$107.06
218HS6464	1"	1.000	12"	9"	\$119.70
218HS7264	1-1/8"	1.125	12"	9"	\$128.47

**18" LONG LONG BOY
GENERAL PURPOSE DRILLS HSS**

SERIES 217HS 118° POINT

PART NUMBER	DRILL SIZE	DEC. EQUIV.	O/A LENGTH	FLUTE LENGTH	PRICE EACH
217HS1264	3/16"	.1875	18"	14"	\$25.87
217HS1464	7/32"	.2188	18"	14"	\$36.80
217HS1664	1/4"	.2500	18"	14"	\$28.65
217HS1864	9/32"	.2812	18"	14"	\$29.68
217HS2064	5/16"	.3125	18"	14"	\$31.81
217HS2264	11/32"	.3438	18"	14"	\$34.30
217HS2464	3/8"	.3750	18"	14"	\$37.10
217HS2664	13/32"	.4062	18"	14"	\$46.85
217HS2864	7/16"	.4375	18"	14"	\$49.12
217HS3064	15/32"	.4688	18"	14"	\$59.76
217HS3264	1/2"	.5000	18"	14"	\$62.18
217HS3664	9/16"	.5625	18"	14"	\$80.50
217HS4064	5/8"	.6250	18"	14"	\$80.75
217HS4864	3/4"	.7500	18"	14"	\$101.44

MAIN OFFICE

INTERNATIONAL TOOL MANUFACTURING
71-08 51ST. AVENUE, WOODSIDE, NY 11377
(718) 446-0711 • (800) 247-5696 • FAX (718) 899-6553



INTERNATIONAL TOOL MANUFACTURING
675-E-PROGRESS CENTER AVE., LAWRENCEVILLE, GA 30043
(770) 962-5454 • (800) 229-1776 • FAX (770) 962-5869

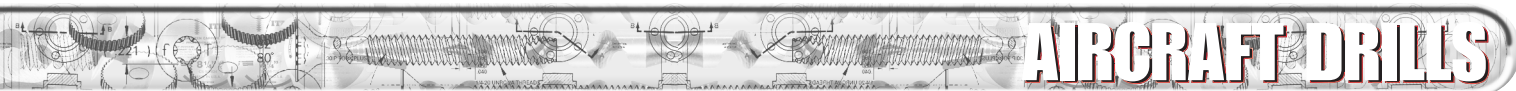

AIRCRAFT DRILLS

**135°
SPLIT
POINT**



**6" AIRCRAFT
HEAVY DUTY DRILLS SUPER HSS**

SERIES 212SP 135° SPLIT POINT

PART NUMBER	DRILL SIZE	DEC. EQUIV.	O/A LENGTH	FLUTE LENGTH	PRICE EACH
212SP0464	1/16"	.0625	6"	7/8"	\$3.20
212SP0864	1/8"	.1250	6"	1-5/8"	\$2.27
212SP0964	9/64"	.1406	6"	1-3/4"	\$2.54
212SP1064	5/32"	.1562	6"	2"	\$2.74
212SP1164	11/64"	.1719	6"	2-1/8"	\$3.09
212SP1264	3/16"	.1875	6"	2-5/16"	\$3.35
212SP1364	13/64"	.2031	6"	2-7/16"	\$3.49
212SP1464	7/32"	.2188	6"	2-1/2"	\$3.81
212SP1564	15/64"	.2344	6"	2-5/8"	\$3.84
212SP1664	1/4"	.2500	6"	2-3/4"	\$3.96
212SP1764	17/64"	.2656	6"	2-7/8"	\$4.62
212SP1864	9/32"	.2812	6"	2-15/16"	\$5.33
212SP1964	19/64"	.2969	6"	3-1/16"	\$6.12
212SP2064	5/16"	.3125	6"	3-3/16"	\$6.79
212SP2164	21/64"	.3281	6"	3-5/16"	\$7.74
212SP2264	11/32"	.3438	6"	3-7/16"	\$7.87
212SP2364	23/64"	.3594	6"	3-1/2"	\$8.12
212SP2464	3/8"	.3750	6"	3-5/8"	\$8.79
212SP2564	25/64"	.3906	6"	3-3/4"	\$8.99
212SP2664	13/32"	.4062	6"	3-7/8"	\$9.37
212SP2764	27/64"	.4219	6"	3-15/16"	\$9.85
212SP2864	7/16"	.4375	6"	4-1/16"	\$11.00
212SP2964	29/64"	.4531	6"	4-3/32"	\$11.33
212SP3064	15/32"	.4688	6"	4-5/16"	\$11.33
212SP3164	31/64"	.4844	6"	4-3/8"	\$12.62
212SP3264	1/2"	.5000	6"	4-1/2"	\$12.62

**12" AIRCRAFT
HEAVY DUTY DRILLS SUPER HSS**

SERIES 214SP 135° SPLIT POINT

PART NUMBER	DRILL SIZE	DEC. EQUIV.	O/A LENGTH	FLUTE LENGTH	PRICE EACH
214SP0864	1/8"	.1250	12"	1-5/8"	\$5.48
214SP1064	5/32"	.1562	12"	2"	\$6.43
214SP1264	3/16"	.1875	12"	2-5/16"	\$7.02
214SP1464	7/32"	.2188	12"	2-1/2"	\$7.52
214SP1664	1/4"	.2500	12"	2-3/4"	\$8.04
214SP1864	9/32"	.2812	12"	2-15/16"	\$9.53
214SP2064	5/16"	.3125	12"	3-3/16"	\$10.87
214SP2264	11/32"	.3438	12"	3-7/16"	\$12.18
214SP2464	3/8"	.3750	12"	3-5/8"	\$13.85
214SP2664	13/32"	.4062	12"	3-7/8"	\$15.15
214SP2864	7/16"	.4375	12"	4-1/16"	\$17.26
214SP3064	15/32"	.4688	12"	4-5/16"	\$19.24
214SP3264	1/2"	.5000	12"	4-1/2"	\$21.00

**18" AIRCRAFT
HEAVY DUTY DRILLS SUPER HSS**

SERIES 215SP 135° SPLIT POINT

PART NUMBER	DRILL SIZE	DEC. EQUIV.	O/A LENGTH	FLUTE LENGTH	PRICE EACH
215SP1264	3/16"	.1875	18"	2-5/16"	\$12.98
215SP1664	1/4"	.2500	18"	2-3/4"	\$14.31
215SP2064	5/16"	.3125	18"	3-3/16"	\$25.37
215SP2464	3/8"	.3750	18"	3-5/8"	\$27.02
215SP2864	7/16"	.4375	18"	4-1/16"	\$36.66
215SP3264	1/2"	.5000	18"	4-1/2"	\$37.47

6" - 12" LONG WIRE SIZE AIRCRAFT DRILLS HSS

SERIES 213SP

135° SPLIT POINT

PART NUMBER	DRILL SIZE	O/A LENGTH	PRICE EACH
213SP0001 To 213SP0009	#1 To #9	6"	\$5.42
213SP0010 To 213SP0019	#10 To #19	6"	\$4.52
213SP0020 To 213SP0029	#20 To #29	6"	\$4.14
213SP0030 To 213SP0039	#30 To #39	6"	\$3.37
213SP0040 To 213SP0049	#40 To #49	6"	\$4.56
213SP0050 To 213SP0060	#50 To #60	6"	\$11.01

PART NUMBER	DRILL SIZE	DEC. EQUIV.	O/A LENGTH	FLUTE LENGTH	PRICE EACH
213SP1201	1	.2280	12"	3-7/8"	\$5.95

AIRCRAFT

- Straight Shank
- Ground Shank
- M2 High Speed Steel
- Extra Flexibility For Drilling In Inaccessible Areas
- Suitable for
 - Stainless Steel
 - Medium Alloyed Materials

SOLD INDIVIDUALLY

MAIN OFFICE

INTERNATIONAL TOOL MANUFACTURING
71-08 51ST. AVENUE, WOODSIDE, NY 11377
(718) 446-0711 • (800) 247-5696 • FAX (718) 899-6553



INTERNATIONAL TOOL MANUFACTURING
675-E-PROGRESS CENTER AVE., LAWRENCEVILLE, GA 30043
(770) 962-5454 • (800) 229-1776 • FAX (770) 962-5869

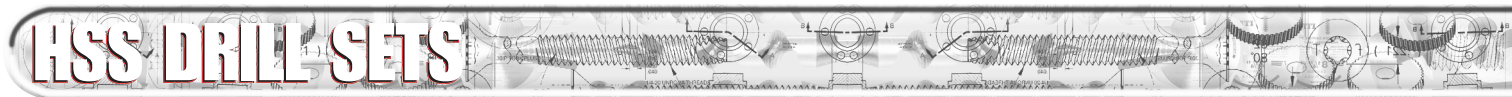

13 Pc. Sets

13 PC. JOBBER SETS IN METAL INDEXES

JOBBER DRILL SIZES 1/16" TO 1/4" BY 64THS. STRAIGHT SHANK.

PART NUMBER	DRILL TYPE	DRILL COLOR	POINT SIZE	SAME DRILL AS PAGE #	PRICE EACH
206SP0013	HEAVY DUTY HSS TRITON	BLACK	135° S.P.	10	\$18.72
206US0013	HEAVY DUTY HSS SUPERBA	BLACK & GOLD	135° S.P.	11	\$22.92
221CO0013	COBALT	GOLD	135° S.P.	12	\$38.84

S.P. = Split Point



15 Pc. Sets

15 PC. JOBBER SETS IN METAL INDEXES

JOBBER DRILL SIZES 1/16" TO 1/2" BY 32NDS. STRAIGHT SHANK.

PART NUMBER	DRILL TYPE	DRILL COLOR	POINT SIZE	SAME DRILL AS PAGE #	PRICE EACH
206SP0015	HEAVY DUTY HSS TRITON	BLACK	135° S.P.	10	\$62.49
206US0015	HEAVY DUTY HSS SUPERBA	BLACK & GOLD	135° S.P.	11	\$76.51
221CO0015	COBALT	GOLD	135° S.P.	12	\$120.74

S.P. = Split Point

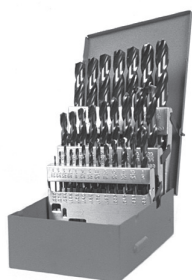

29 Pc. Sets

29 PC. JOBBER SETS IN METAL INDEXES

JOBBER DRILL SIZES 1/16" TO 1/2" BY 64THS. STRAIGHT SHANK.

PART NUMBER	DRILL TYPE	DRILL COLOR	POINT SIZE	SAME DRILL AS PAGE #	PRICE EACH
202BF0029	GENERAL PURPOSE HSS	BLACK	11 8 °	9	\$85.98
252US0029	GENERAL PURPOSE HSS	BRIGHT	11 8 °	10	\$107.36
206SP0029	HEAVY DUTY HSS TRITON	BLACK	135° S.P.	10	\$112.45
206US0029	HEAVY DUTY HSS SUPERBA	BLACK & GOLD	135° S.P.	11	\$137.67
221CO0029	COBALT	GOLD	135° S.P.	12	\$214.82
258TN0029	TITANIUM	BRIGHT GOLD	135° S.P.	12	\$271.07

S.P. = Split Point

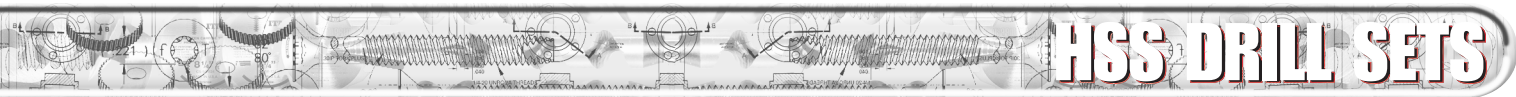

REDUCED SHANK 29 PC. JOBBER SETS

JOBBER DRILL SIZES 1/16" TO 1/2" BY 64THS. 1/4" AND 3/8" REDUCED SHANKS.

PART NUMBER	DRILL TYPE	DRILL COLOR	POINT SIZE	SAME DRILL AS PAGE #	PRICE EACH
206R80029	3/8" SHANK H.D. HSS TRITON 1/16" - 3/8" STRAIGHT SHANK, 25/64" - 1/2" WITH 3/8" SHANK	BLACK	135° S.P.	13	\$129.14
206USR829	3/8" SHANK H.D. HSS SUPERBA 1/16" - 3/8" STRAIGHT SHANK, 25/64" - 1/2" WITH 3/8" SHANK	BLACK & GOLD	135° S.P.	13	\$158.10
221SL0029	3/8" SHANK COBALT 1/16" - 3/8" STRAIGHT SHANK, 25/64" - 1/2" WITH 3/8" SHANK	GOLD	135° S.P.	13	\$233.61

S.P. = Split Point

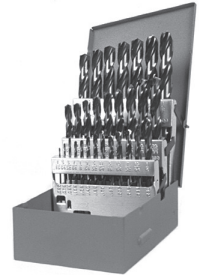

29 Pc. Sets
REDUCED SHANK

8 PC. SILVER & DEMING SETS

SILVER & DEMING DRILL SIZES 9/16", 5/8", 11/16", 3/4", 13/16", 7/8", 15/16", 1"

PART NUMBER	DRILL TYPE	DRILL COLOR	POINT SIZE	SAME DRILL AS PAGE #	PRICE EACH
202SD0008	GENERAL PURPOSE HSS	BLACK	118°	16	\$187.22
206SD0008	HEAVY DUTY HSS SUPERBA	BLACK & GOLD	118° S.P.	17	\$260.74

S.P. = Split Point



SILVER & DEMING

WIRE GAUGE SETS IN METAL INDEXES

WIRE GAUGE DRILL SIZES #1 TO #60

PART NUMBER	DRILL TYPE	DRILL COLOR	POINT SIZE	SAME DRILL AS PAGE #	PRICE EACH
206SP0060	#1-#60 HEAVY DUTY HSS TRITON	BLACK	135° S.P.	19	\$96.84

S.P. = Split Point



WIRE GAUGE

MAIN OFFICE

INTERNATIONAL TOOL MANUFACTURING
71-08 51ST. AVENUE, WOODSIDE, NY 11377
(718) 446-0711 • (800) 247-5696 • FAX (718) 899-6553



INTERNATIONAL TOOL MANUFACTURING
675-E-PROGRESS CENTER AVE., LAWRENCEVILLE, GA 30043
(770) 962-5454 • (800) 229-1776 • FAX (770) 962-5869

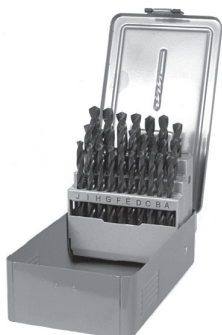
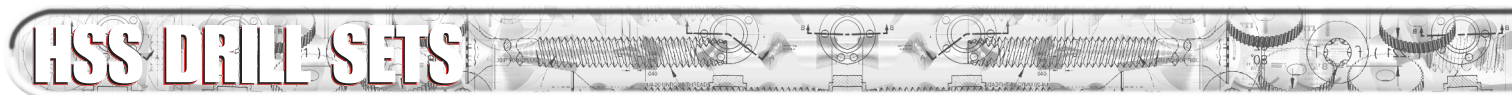

LETTER

LETTER A TO Z SET IN METAL INDEX

LETTER SIZES "A" - "Z". STRAIGHT SHANK.

PART NUMBER	DRILL TYPE	DRILL COLOR	POINT SIZE	SAME DRILL AS PAGE #	PRICE EACH
206SP26AZ	HEAVY DUTY HSS (TRITON)	BLACK	135° S.P.	20	\$127.76

S.P. = Split Point

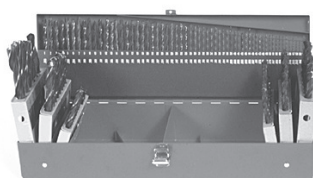

MASTER

115 PC. MASTER SET IN METAL INDEX

JOBBER SIZES 1/16" - 1/2", WIRE GAUGE DRILL SIZES #1 - #60, LETTER SIZES "A" - "Z". STRAIGHT SHANK.

PART NUMBER	DRILL TYPE	DRILL COLOR	POINT SIZE	SAME DRILL AS PAGE #	PRICE EACH
206SP0115	HEAVY DUTY HSS TRITON	BLACK	135° S.P.	10, 18, 20	\$359.31

S.P. = Split Point



METRIC

METRIC SETS IN METAL INDEX

METRIC SIZES 1.00MM - 6.00MM / 1.00MM - 13.00MM. STRAIGHT SHANK.

PART NUMBER	DRILL TYPE	DRILL COLOR	POINT SIZE	SAME DRILL AS PAGE #	PRICE EACH
205HS11PC	11 PC (1.00 MM - 6.00 MM) GENERAL PURPOSE HSS	BLACK	11 8°	20	\$21.85
205HS25PC	25 PC (1.00 MM - 13.00 MM) GENERAL PURPOSE HSS	BLACK	11 8°	20	\$115.59

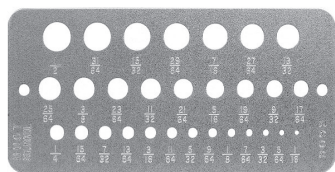

METAL DRILL GAUGES

FOR JOBBER DRILL SIZES & WIRE GAUGE SIZES

PART NUMBER	DESCRIPTION	PRICE EACH
29GAUGE	29 HOLE GAUGE FOR 1/16" - 1/2" JOBBER SIZES	\$6.00
60GAUGE	60 HOLE GAUGE FOR #1 - #60 WIRE GAUGE SIZES	\$8.10

MAIN OFFICE

INTERNATIONAL TOOL MANUFACTURING
71-08 51ST. AVENUE, WOODSIDE, NY 11377
(718) 446-0711 • (800) 247-5696 • FAX (718) 899-6553



INTERNATIONAL TOOL MANUFACTURING
675-E-PROGRESS CENTER AVE., LAWRENCEVILLE, GA 30043
(770) 962-5454 • (800) 229-1776 • FAX (770) 962-5869

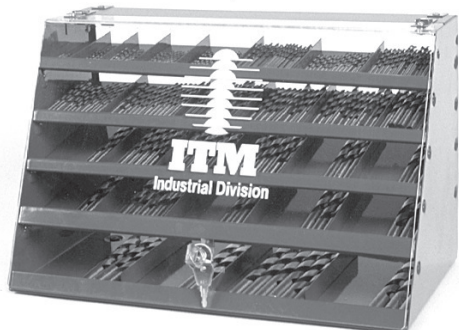

- Same Drills as Page 9.
- Imported.

118° JOBBER DISPENSER		500 PIECES
PART NUMBER	DESCRIPTION OF DRILLS CONTAINED IN DISPENSER	PRICE EACH
202HS0500	500 Pcs. TWO TONE HSS DRILL BITS General Purpose 118° point	\$726.88

- Same Drills as Page 10.
- Made In USA.

118° JOBBER DISPENSER		500 PIECES
PART NUMBER	DESCRIPTION OF DRILLS CONTAINED IN DISPENSER	PRICE EACH
202US0500	500 Pcs. BRIGHT HSS DRILL BITS USA General Purpose 118° point	\$969.58

500 Pc. Dispenser Contains:

24- 1/16"	24- 5/64"	48- 3/32"	24- 7/64"	72- 1/8"
24- 9/64"	60- 5/32"	24- 11/64"	48- 3/16"	24- 13/64"
24- 7/32"	12- 15/64"	36- 1/4"	3- 17/64"	5- 9/32"
3- 19/64"	6- 5/16"	3- 21/64"	3- 11/32"	3- 23/64"
6- 3/8"	3- 25/64"	3- 13/32"	3- 27/64"	3- 7/16"
3- 29/64"	3- 15/32"	3- 31/64"	3- 1/2"	

- Same Drills as Page 10.
- Imported.

135° H.D. JOBBER DISPENSER		500 PIECES
PART NUMBER	DESCRIPTION OF DRILLS CONTAINED IN DISPENSER	PRICE EACH
202SP0500	500 Pcs. BLACK HSS DRILL BITS Heavy Duty 135° split point	\$1031.14

This attractive drill bit merchandiser puts all 29 essential jobber sizes at your fingertips. Made of heavy duty steel construction, this deep red cabinet dispenser fits perfectly on any counter top. Comes with lock and key.

SUPERBA

- Same Drills as Page 11.
- Made In USA.

135° H.D. JOBBER DISPENSER		500 PIECES
PART NUMBER	DESCRIPTION OF DRILLS CONTAINED IN DISPENSER	PRICE EACH
206US0500	500 Pcs. BLACK/GOLD HSS DRILL BITS USA Heavy Duty 135° split point	\$1134.46

SUPERBA MECHANICS

- Same Drills as Page 11.
- Made In USA.

135° H.D. MECHANICS DISPENSER		500 PIECES
PART NUMBER	DESCRIPTION OF DRILLS CONTAINED IN DISPENSER	PRICE EACH
208MC0500	500 Pcs. BLACK/GOLD MECHANICS HSS USA Heavy Duty 135° split point	\$1242.00

- Same Drills as Page 12.
- Imported.

135° COBALT JOBBER DISPENSER		252 PIECES
PART NUMBER	DESCRIPTION OF DRILLS CONTAINED IN DISPENSER	PRICE EACH
221CO0252	252 Pcs. COBALT HSS DRILL BITS Heavy Duty 135° split point 12 pieces each 1/16" → 1/4" 6 pieces each 17/64" → 1/2"	\$1210.82

EMPTY DRILL INDEXES

- ⊙ ALL INDEX CASES ARE NEUTRAL / NON-BRANDED
- ⊙ ALL INDEXES SHIPPED WITH PROTECTIVE SLEEVES.

PART NUMBER	DESCRIPTION	COLOR	MFG.	PRICE EACH
313	13 PC. FRACTIONAL	GRAY	HUOT	\$4.59
15	15 PC. FRACTIONAL	GRAY	HUOT	\$7.65
21	21 PC. FRACTIONAL	GRAY	HUOT	\$7.65
20209	29 PC. FRACTIONAL	RED	HUOT	\$11.25
5160	60 PC. WIRE GAUGE	RED	A. DRILL BOX	\$13.10
5120	115 PC. MASTER	RED	A. DRILL BOX	\$76.95
5126	A-Z LETTER	RED	A. DRILL BOX	\$13.68
4011	11 PC. METRIC	GRAY	HUOT	\$6.99
4025	25 PC. METRIC	GRAY	HUOT	\$8.67
5108	8 PC. SILVER & DEMING	RED	A. DRILL BOX	\$67.91
5798	7 PC. BRAD POINT	RED	A. DRILL BOX	\$20.16
842-2999	500 PC. DISPENSER	RED	A. DRILL BOX	\$255.00

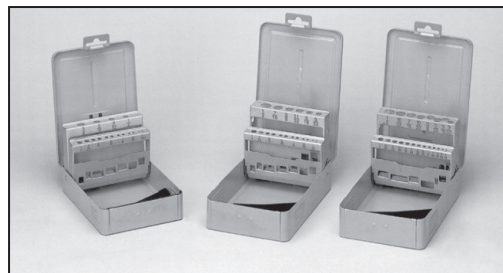

MAIN OFFICE

INTERNATIONAL TOOL MANUFACTURING
71-08 51ST. AVENUE, WOODSIDE, NY 11377
(718) 446-0711 • (800) 247-5696 • FAX (718) 899-6553



INTERNATIONAL TOOL MANUFACTURING
675-E-PROGRESS CENTER AVE., LAWRENCEVILLE, GA 30043
(770) 962-5454 • (800) 229-1776 • FAX (770) 962-5869

ANNULAR CUTTERS - HSS

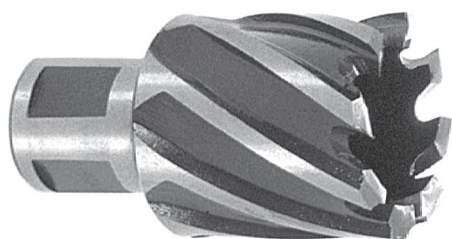

Allows overlap cut on existing holes



BARCODED

- **M2 High Speed Steel**
- **3/4" Shanks**
- Aggressive Cutting Edges
- Industrial Quality
- For All Magnetic Drilling Machines
- Made In England
- Individually Packed With Bar Code

1" HSS ANNULAR CUTTERS

PART NUMBER	CUTTER SIZE	X	O/A LENGTH	PRICE EACH
100MC2864	7/16"	X	1"	\$48.29
100MC3264	1/2"	X	1"	\$48.29
100MC3664	9/16"	X	1"	\$50.49
100MC4064	5/8"	X	1"	\$52.66
100MC4464	11/16"	X	1"	\$56.87
100MC4864	3/4"	X	1"	\$59.28
100MC5264	13/16"	X	1"	\$63.67
100MC5664	7/8"	X	1"	\$72.38
100MC6064	15/16"	X	1"	\$74.68
100MC6464	1"	X	1"	\$81.27
100MC6864	1-1/16"	X	1"	\$83.45
100MC7264	1-1/8"	X	1"	\$92.24
100MC7664	1-3/16"	X	1"	\$95.62
100MC8064	1-1/4"	X	1"	\$105.43
100MC8464	1-5/16"	X	1"	\$127.43
100MC8864	1-3/8"	X	1"	\$136.20
100MC9264	1-7/16"	X	1"	\$162.58
100MC9664	1-1/2"	X	1"	\$166.99
100MC1916	1-9/16"	X	1"	\$171.36
100MC1058	1-5/8"	X	1"	\$180.18
100MC1116	1-11/16"	X	1"	\$188.96
100MC1034	1-3/4"	X	1"	\$202.10
100MC1316	1-13/16"	X	1"	\$210.93
100MC1078	1-7/8"	X	1"	\$219.75
100MC1516	1-15/16"	X	1"	\$219.75
100MC2002	2"	X	1"	\$237.30
100MC2116	2-1/16"	X	1"	\$246.12

2" HSS ANNULAR CUTTERS

PART NUMBER	CUTTER SIZE	X	O/A LENGTH	PRICE EACH
200MC2864	7/16"	X	2"	\$61.49
200MC3264	1/2"	X	2"	\$61.49
200MC3664	9/16"	X	2"	\$65.60
200MC4064	5/8"	X	2"	\$74.68
200MC4464	11/16"	X	2"	\$83.45
200MC4864	3/4"	X	2"	\$87.86
200MC5264	13/16"	X	2"	\$96.64
200MC5664	7/8"	X	2"	\$105.34
200MC6064	15/16"	X	2"	\$109.84
200MC6464	1"	X	2"	\$118.60
200MC6864	1-1/16"	X	2"	\$123.02
200MC7264	1-1/8"	X	2"	\$131.80
200MC7664	1-3/16"	X	2"	\$135.18
200MC8064	1-1/4"	X	2"	\$144.99
200MC8464	1-5/16"	X	2"	\$162.58
200MC8864	1-3/8"	X	2"	\$171.36
200MC9264	1-7/16"	X	2"	\$188.96
200MC9664	1-1/2"	X	2"	\$197.74
200MC1916	1-9/16"	X	2"	\$224.12
200MC1058	1-5/8"	X	2"	\$224.12
200MC1116	1-11/16"	X	2"	\$241.71
200MC1034	1-3/4"	X	2"	\$250.50
200MC1316	1-13/16"	X	2"	\$259.32
200MC1078	1-7/8"	X	2"	\$286.35
200MC1516	1-15/16"	X	2"	\$286.35
200MC2002	2"	X	2"	\$320.70
200MC2116	2-1/16"	X	2"	\$332.17

MAIN OFFICE

INTERNATIONAL TOOL MANUFACTURING
71-08 51ST. AVENUE, WOODSIDE, NY 11377
(718) 446-0711 • (800) 247-5696 • FAX (718) 899-6553



INTERNATIONAL TOOL MANUFACTURING
675-E-PROGRESS CENTER AVE., LAWRENCEVILLE, GA 30043
(770) 962-5454 • (800) 229-1776 • FAX (770) 962-5869

ANNULAR CUTTERS - HSS

PILOT PINS

PART NUMBER	DESCRIPTION	PRICE EACH
PJ00011	PILOT FOR 1" CUTTER	\$9.03
PJ00021	PILOT FOR 2" CUTTER	\$11.10
PJ00716	PILOT FOR 7/16 X 1" CUTTER ONLY	\$9.03
PJ02716	PILOT FOR 7/16 X 2" CUTTER ONLY	\$11.10



For Use With All **ITM** and Conventional Annular Cutters. Pilot Pins are Necessary For:

- 1) **Aligning Annular Cutters to Precise Drilling Point.**
- 2) **Providing a Steady Flow of Lubricant to the Cutting Edges.**
- 3) **Ejecting the Slug From The Center of Cutter Once Drilling is Complete.**



Pilots & Adapters will work with the following Magnetic Drill Machines:

- Unibor SE100/32, E100/32, E40
- Magnabor 18581
- Slugger MT3S, MT3
- Champion RB65

Note: Above companies are not associated with **ITM** in any way.

INDUSTRIAL ADAPTERS

PART NUMBER	DESCRIPTION	PRICE EACH
AD0002	ADAPTER MORSE #2	\$303.48
AD0003	ADAPTER MORSE #3	\$319.68

Converts Morse Tapers to 3/4" Arbor for All **ITM** and Conventional Annular Cutters.

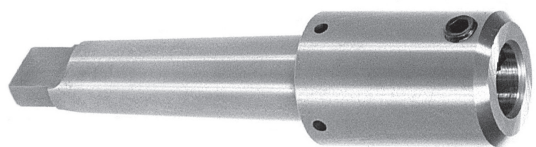

3/16" Hex Setting Screws.

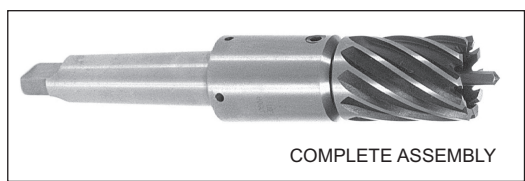
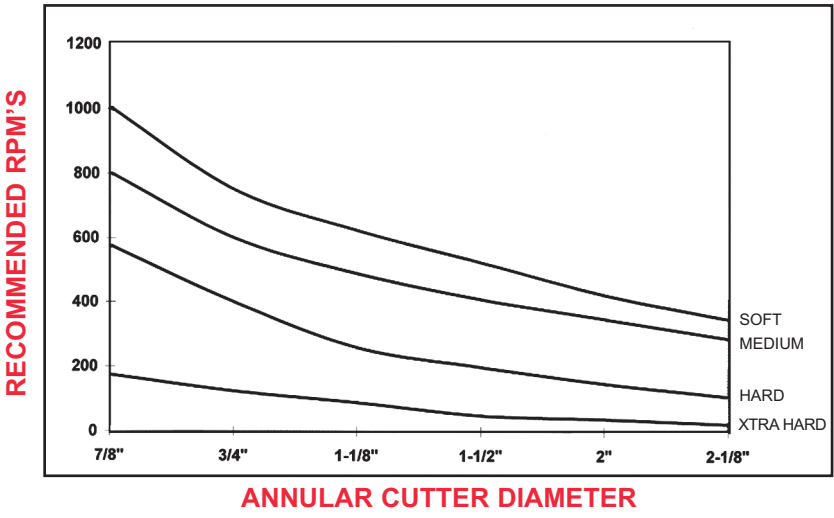

- ITM** Makes it Fast, Easy, & Convenient:
- Tooth Geometry provides greater mass in the cutting edge to dissipate heat.
 - One 3/4" Arbor system, instead of two, makes it easy & cost effective.
 - No center punching required.
 - Tougher & more durable than carbide cutters.
 - Cuts faster with less friction for longer life.
 - Can cut up to 2" thick.
 - 100% Satisfaction Guaranteed.

MAIN OFFICE

INTERNATIONAL TOOL MANUFACTURING
71-08 51ST. AVENUE, WOODSIDE, NY 11377
(718) 446-0711 • (800) 247-5696 • FAX (718) 899-6553



INTERNATIONAL TOOL MANUFACTURING
675-E-PROGRESS CENTER AVE., LAWRENCEVILLE, GA 30043
(770) 962-5454 • (800) 229-1776 • FAX (770) 962-5869

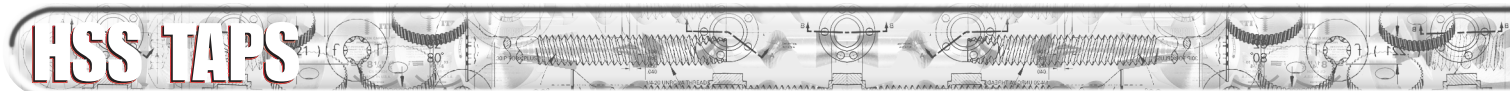

TAPER

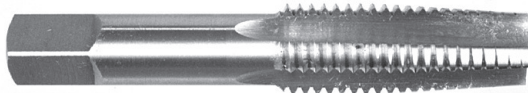
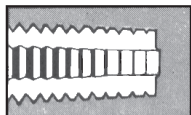

8 to 10 threads chamfered for easy thread starting in tough material.

PLUG

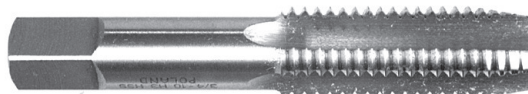
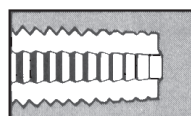

3 to 5 threads chamfered for general use when tapping to bottom of hole is not critical. **This is the most popular tap of all three styles.**

BOTTOMING

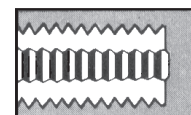

1-1/2 threads chamfered for use after threads have been started. Used for clean tapping to bottom of holes.



Packaging:

Sizes
0-80 → 1/2"-20
5 / box

Sold Individually
over 1/2"-20.



Tap-Drill Reference Chart Available on Page 118.

NC = National Course NF = National Fine

HSS GROUND THREAD HAND TAPS - MACHINE SCREW

SERIES 262 - 263 - 264 NF/NC

MACHINE SCREW HIGH SPEED STEEL TAPS

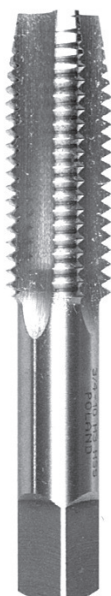

PART NUMBER			MACHINE SCREW THREAD	No. OF FLUTES	GROUND THREAD LIMIT	O/A LENGTH	THREAD LENGTH	USE DRILL SIZE	PRICE EACH
TAPER	PLUG	BOTTOMING							
262NF0000	263NF0000	264NF0000	0-80 NF	2	H1	1-5/8"	5/16"	3/64"	\$9.25
262NC0001	263NC0001	264NC0001	1-64 NC	2	H1	1-11/16"	3/8"	53	\$9.10
262NF0001	263NF0001	264NF0001	1-72 NF	2	H2	1-11/16"	3/8"	53	\$9.10
262NC0002	263NC0002	264NC0002	2-56 NC	3	H2	1-3/4"	7/16"	50	\$7.73
262NF0002	263NF0002	264NF0002	2-64 NF	3	H2	1-3/4"	7/16"	50	\$7.73
262NC0003	263NC0003	264NC0003	3-48 NC	3	H2	1-13/16"	1/2"	47	\$6.13
262NF0003	263NF0003	264NF0003	3-56 NF	3	H2	1-13/16"	1/2"	45	\$6.13
262NC0004	263NC0004	264NC0004	4-40 NC	3	H2	1-7/8"	9/16"	43	\$5.00
262NF0004	263NF0004	264NF0004	4-48 NF	3	H2	1-7/8"	9/16"	42	\$5.00
262NC0005	263NC0005	264NC0005	5-40 NC	3	H2	1-15/16"	7/8"	38	\$5.00
262NF0005	263NF0005	264NF0005	5-44 NF	3	H2	1-15/16"	7/8"	37	\$5.00
262NC0006	263NC0006	264NC0006	6-32 NC	3	H2	2"	11/16"	35	\$4.09
262NF0006	263NF0006	264NF0006	6-40 NF	3	H2	2"	11/16"	33	\$4.09
262NC0008	263NC0008	264NC0008	8-32 NC	4	H3	2-1/8"	3/4"	29	\$4.24
262NF0008	263NF0008	264NF0008	8-36 NF	4	H3	2-1/8"	3/4"	29	\$4.24
262NC0010	263NC0010	264NC0010	10-24 NC	4	H3	2-3/8"	7/8"	25	\$4.41
262NF0010	263NF0010	264NF0010	10-32 NF	4	H3	2-3/8"	7/8"	21	\$4.41
262NC0012	263NC0012	264NC0012	12-24 NC	4	H3	2-3/8"	15/16"	16	\$4.69
262NF0012	263NF0012	264NF0012	12-28 NF	4	H3	2-3/8"	15/16"	14	\$4.69

MAIN OFFICE

INTERNATIONAL TOOL MANUFACTURING
71-08 51ST. AVENUE, WOODSIDE, NY 11377
(718) 446-0711 • (800) 247-5696 • FAX (718) 899-6553



INTERNATIONAL TOOL MANUFACTURING
675-E-PROGRESS CENTER AVE., LAWRENCEVILLE, GA 30043
(770) 962-5454 • (800) 229-1776 • FAX (770) 962-5869

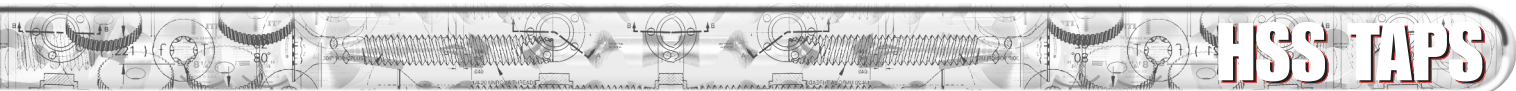

HSS GROUND THREAD HAND TAPS - FRACTIONAL

SERIES 265 - 266 - 267 NF/NC FRACTIONAL HIGH SPEED STEEL TAPS

PART NUMBER			MACHINE SCREW THREAD	No. OF FLUTES	GROUND THREAD LIMIT	O/A LENGTH	THREAD LENGTH	USE DRILL SIZE	PRICE EACH
TAPER	PLUG	BOTTOMING							
265NC0310	266NC0310	267NC0310	1/4"-20 NC	4	H3	2-1/2"	1"	7	\$4.64
265NF0312	266NF0312	267NF0312	1/4"-28 NF	4	H3	2-1/2"	1"	3	\$4.64
265NC0315	266NC0315	267NC0315	5/16"-18 NC	4	H3	2-23/32"	1-1/8"	F	\$5.47
265NF0316	266NF0316	267NF0316	5/16"-24 NF	4	H3	2-23/32"	1-1/8"	I	\$5.47
265NC0318	266NC0318	267NC0318	3/8"-16 NC	4	H3	2-15/16"	1-1/4"	5/16"	\$6.41
265NF0319	266NF0319	267NF0319	3/8"-24 NF	4	H3	2-15/16"	1-1/4"	Q	\$6.41
265NC0320	266NC0320	267NC0320	7/16"-14 NC	4	H3	3-5/32"	1-7/16"	U	\$9.93
265NF0321	266NF0321	267NF0321	7/16"-20 NF	4	H3	3-5/32"	1-7/16"	25/64"	\$9.93
265NC0322	266NC0322	267NC0322	1/2"-13 NC	4	H3	3-3/8"	1-21/32"	27/64"	\$11.78
265NF0323	266NF0323	267NF0323	1/2"-20 NF	4	H3	3-3/8"	1-21/32"	29/64"	\$11.78
265NC0325	266NC0325	267NC0325	9/16"-12 NC	4	H3	3-19/32"	1-21/32"	31/64"	\$13.92
265NF0326	266NF0326	267NF0326	9/16"-18 NF	4	H3	3-19/32"	1-21/32"	33/64"	\$13.92
265NC0327	266NC0327	267NC0327	5/8"-11 NC	4	H3	3-13/16"	1-13/16"	17/32"	\$16.43
265NF0328	266NF0328	267NF0328	5/8"-18 NF	4	H3	3-13/16"	1-13/16"	37/64"	\$16.43
265NS0329	266NS0329	267NS0329	11/16"-11 NS	4	H3	4-1/32"	1-13/16"	19/32"	\$17.73
265NS0330	266NS0330	267NS0330	11/16"-16 NS	4	H3	4-1/32"	1-13/16"	5/8"	\$17.73
265NC0331	266NC0331	267NC0331	3/4"-10 NC	4	H3	4-1/4"	2"	21/32"	\$26.22
265NF0332	266NF0332	267NF0332	3/4"-16 NF	4	H3	4-1/4"	2"	11/16"	\$26.22
265NC0333	266NC0333	267NC0333	7/8"-9 NC	4	H4	4-11/16"	2-7/32"	49/64"	\$33.53
265NF0334	266NF0334	267NF0334	7/8"-14 NF	4	H4	4-11/16"	2-7/32"	13/16"	\$33.53
265NC0335	266NC0335	267NC0335	1"-8 NC	4	H4	5-1/8"	2-1/2"	7/8"	\$45.13
265NF0336	266NF0336	267NF0336	1"-12 NF	4	H4	5-1/8"	2-1/2"	59/64"	\$45.13
265NC0337	266NC0337	267NC0337	1"-14 NS	4	H4	5-1/8"	2-1/2"	15/16"	\$45.13
265NC0338	266NC0338	267NC0338	1-1/8"- 7 NC	4	H4	5-7/16"	2-9/16"	63/64"	\$77.77
265NF0339	266NF0339	267NF0339	1-1/8"- 12 NF	4	H4	5-7/16"	2-9/16"	1-3/64"	\$82.11
265NC0340	266NC0340	267NC0340	1-1/4"- 7 NC	4	H4	5-3/4"	2-9/16"	1-7/64"	\$102.02
265NF0341	266NF0341	267NF0341	1-1/4"- 12 NF	6	H4	5-3/4"	2-9/16"	1-11/64"	\$103.99
265NC0342	266NC0342	267NC0342	1-3/8"- 6 NC	4	H4	6-1/16"	3"	1-7/32"	\$127.90
265NF0343	266NF0343	267NF0343	1-3/8"- 12 NF	6	H4	6-1/8"	3"	1-19/64"	\$129.84
265NC0344	266NC0344	267NC0344	1-1/2"- 6 NC	4	H4	6-3/8"	3"	1-11/32"	\$147.87
265NF0345	266NF0345	267NF0345	1-1/2"- 12 NF	6	H4	6-3/8"	3"	1-17/64"	\$150.22



5 PCS. PER PACK
FROM 0-80 TO 1/2"-20.
SOLD INDIVIDUALLY
OVER 1/2"-20.

TAP & DRILL SET

19 PC. SET NC HSS GROUND THREAD

PART NUMBER	DESCRIPTION	PRICE EACH
TD-SP-019	19 PC. HSS TAPS & GENERAL PURPOSE DRILLS	\$72.31
6-32	5/16"-18 #36 #F	
8-32	3/8"-16 #29 5/16"	
10-24	7/16"-14 #25 #U	
10-32	1/2"-13 #21 27/64"	
1/4"-20	#7	



- HSS Taps.
- HSS Drill Bits.
- Ground Thread.
- Top Quality.

MAIN OFFICE

INTERNATIONAL TOOL MANUFACTURING
71-08 51ST. AVENUE, WOODSIDE, NY 11377
(718) 446-0711 • (800) 247-5696 • FAX (718) 899-6553



INTERNATIONAL TOOL MANUFACTURING
675-E-PROGRESS CENTER AVE., LAWRENCEVILLE, GA 30043
(770) 962-5454 • (800) 229-1776 • FAX (770) 962-5869

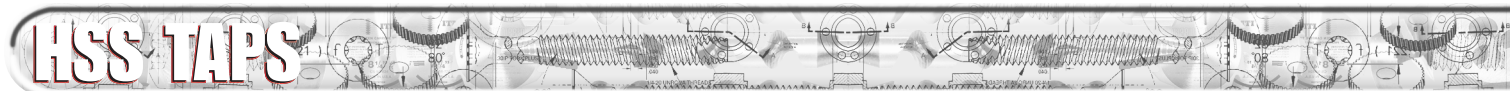

- NPT
- High Speed Steel.
- Ground Thread.
- Top Quality.

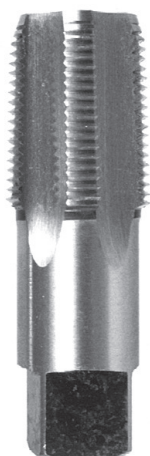

SOLD INDIVIDUALLY
IN PLASTIC BOXES



NPT Tap-Drill Chart Available on Page 117.

TAPER PIPE TAPS - NPT

SERIES 265TP HIGH SPEED GROUND THREAD

PART NUMBER	SIZE	THREADS PER INCH NPT ONLY	No. OF FLUTES	O/A LENGTH	THREAD LENGTH	PRICE EACH
265TP0464	1/16"	27	4	2-1/8"	11/16"	\$13.13
265TP0864	1/8"	27	4	2-1/8"	3/4"	\$13.13
265TP1664	1/4"	18	4	2-7/16"	1-1/16"	\$14.71
265TP2464	3/8"	18	4	2-9/16"	1-1/16"	\$19.10
265TP3264	1/2"	14	4	3-1/8"	1-3/8"	\$30.59
265TP4864	3/4"	14	5	3-1/4"	1-3/8"	\$47.53
265TP6464	1"	11.5"	5	3-3/4"	1-3/4"	\$72.17
265TP8064	1-1/4"	11.5"	5	4"	1-3/4"	\$102.83
265TP9664	1-1/2"	11.5"	7	4-1/4"	1-3/4"	\$137.94
265TP9964	2"	11.5"	7	4-1/2"	1-3/4"	\$187.96

SPIRAL POINT (GUN) TAPS

SERIES 265SP HIGH SPEED STEEL GUN TAP

PART NUMBER	SIZE	No. OF FLUTES	O/A LENGTH	THREAD LENGTH	DRILL SIZE	PRICE EACH
265SP0632	6-32	2	2"	11/16"	35	\$5.52
265SP0832	8-32	2	2-1/8"	3/4"	29	\$5.52
265SP1024	10-24	2	2-3/8"	7/8"	25	\$5.77
265SP1224	12-24	2	2-3/8"	15/16"	16	\$6.02
265SP1420	1/4"-20	2	2-1/2"	1"	7	\$5.39
265SP1428	1/4"-28	2	2-1/2"	1"	7	\$4.28
265SP5618	5/16"-18	2	2-23/32"	1-1/8"	F	\$5.77
265SP3816	3/8"-16	3	2-15/16"	1-1/4"	5/16"	\$7.16
265SP1312	1/2"-13	3	3-3/8"	1-21/32"	27/64"	\$12.15

Spiral Point Taps are ideal for machine tapping through holes or blind holes with adequate bottom clearance.



Sold
5/Pack

COMBINATION DRILL TAPS

SERIES 266TD HIGH SPEED STEEL DRILL-TAP

PART NUMBER	THREAD SIZE	DRILL SIZE	THREAD LENGTH	O/A LENGTH	PRICE EACH
266TD0632	6-32	.1095	11/16"	2"	\$18.33
266TD0832	8-32	.1360	3/4"	2-1/8"	\$18.72
266TD0836	8-36	.1360	3/4"	2-1/8"	\$18.80
266TD1024	10-24	.1520	7/8"	2-3/8"	\$19.43
266TD1032	10-32	.1520	7/8"	2-3/8"	\$19.43
266TD1224	12-24	.1770	15/16"	2-3/8"	\$20.42
267TD1420	1/4"-20	.2010	15/16"	2-1/2"	\$22.70
267TD1428	1/4"-28	.2010	15/16"	2-1/2"	\$22.70
267TD5618	5/16"-18	.2570	1-1/8"	3"	\$27.26
267TD3816	3/8"-16	.3125	1-1/4"	3-1/2"	\$31.73
267TD3824	3/8"-24	.3125	1-1/4"	3-1/2"	\$31.73
267TD7614	7/16"-14	.3680	1-7/16"	3-7/8"	\$37.68
267TD1213	1/2"-13	.4250	1-21/32"	4-1/4"	\$44.54

Drill and Tap holes in one operation, saving a complete set-up!

SOLD INDIVIDUALLY
IN PLASTIC BOXES

MAIN OFFICE

INTERNATIONAL TOOL MANUFACTURING
71-08 51ST. AVENUE, WOODSIDE, NY 11377
(718) 446-0711 • (800) 247-5696 • FAX (718) 899-6553



INTERNATIONAL TOOL MANUFACTURING
675-E-PROGRESS CENTER AVE., LAWRENCEVILLE, GA 30043
(770) 962-5454 • (800) 229-1776 • FAX (770) 962-5869

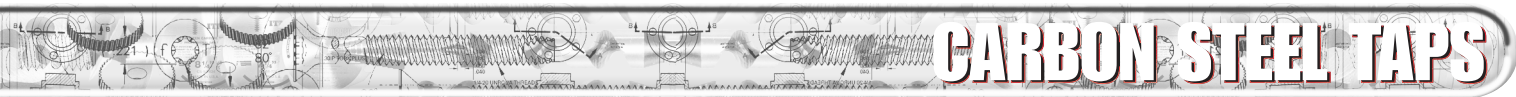

CARBON STEEL HAND TAPS - MACHINE SCREW

SERIES C62 - C63 - C64 NF/NC MACHINE SCREW CARBON STEEL TAPS

PART NUMBER			MACHINE SCREW THREAD	No. OF FLUTES	GROUND THREAD LIMIT	O/A LENGTH	THREAD LENGTH	USE DRILL SIZE	PRICE EACH
TAPER	PLUG	BOTTOMING							
C62NC0004	C63NC0004	C64NC0004	4-40 NC	3	H2	1-7/8"	9/16"	43	\$1.78
C62NF0004	C63NF0004	C64NF0004	4-48 NF	3	H2	1-7/8"	9/16"	42	\$1.78
C62NC0005	C63NC0005	C64NC0005	5-40 NC	3	H2	1-15/16"	7/8"	38	\$1.78
C62NF0005	C63NF0005	C64NF0005	5-44 NF	3	H2	1-15/16"	7/8"	37	\$1.78
C62NC0006	C63NC0006	C64NC0006	6-32 NC	3	H2	2"	11/16"	35	\$1.78
C62NF0006	C63NF0006	C64NF0006	6-40 NF	3	H2	2"	11/16"	33	\$1.78
C62NC0008	C63NC0008	C64NC0008	8-32 NC	4	H3	2-1/8"	3/4"	29	\$1.86
C62NF0008	C63NF0008	C64NF0008	8-36 NF	4	H3	2-1/8"	3/4"	29	\$1.86
C62NC0010	C63NC0010	C64NC0010	10-24 NC	4	H3	2-3/8"	7/8"	25	\$1.97
C62NF0010	C63NF0010	C64NF0010	10-32 NF	4	H3	2-3/8"	7/8"	21	\$1.97
C62NC0012	C63NC0012	C64NC0012	12-24 NC	4	H3	2-3/8"	15/16"	16	\$2.96
C62NF0012	C63NF0012	C64NF0012	12-28 NF	4	H3	2-3/8"	15/16"	14	\$2.96

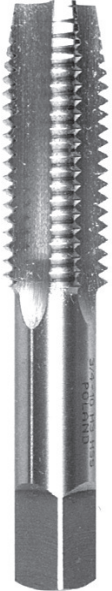

CARBON STEEL HAND TAPS - FRACTIONAL

SERIES C65 - C66 - C67 NF/NC FRACTIONAL CARBON STEEL TAPS

PART NUMBER			MACHINE SCREW THREAD	No. OF FLUTES	GROUND THREAD LIMIT	O/A LENGTH	THREAD LENGTH	USE DRILL SIZE	PRICE EACH
TAPER	PLUG	BOTTOMING							
C65NC0310	C66NC0310	C67NC0310	1/4"-20 NC	4	H3	2-1/2"	1"	7	\$2.05
C65NF0312	C66NF0312	C67NF0312	1/4"-28 NF	4	H3	2-1/2"	1"	3	\$2.05
C65NC0315	C66NC0315	C67NC0315	5/16"-18 NC	4	H3	2-23/32"	1-1/8"	F	\$2.68
C65NF0316	C66NF0316	C67NF0316	5/16"-24 NF	4	H3	2-23/32"	1-1/8"	I	\$2.68
C65NC0318	C66NC0318	C67NC0318	3/8"-16 NC	4	H3	2-15/16"	1-1/4"	5/16"	\$3.33
C65NF0319	C66NF0319	C67NF0319	3/8"-24 NF	4	H3	2-15/16"	1-1/4"	Q	\$3.33
C65NC0320	C66NC0320	C67NC0320	7/16"-14 NC	4	H3	3-5/32"	1-7/16"	U	\$3.77
C65NF0321	C66NF0321	C67NF0321	7/16"-20 NF	4	H3	3-5/32"	1-7/16"	25/64"	\$3.77
C65NC0322	C66NC0322	C67NC0322	1/2"-13 NC	4	H3	3-3/8"	1-21/32"	27/64"	\$5.03
C65NF0323	C66NF0323	C67NF0323	1/2"-20 NF	4	H3	3-3/8"	1-21/32"	29/64"	\$5.03
C65NC0325	C66NC0325	C67NC0325	9/16"-12 NC	4	H3	3-19/32"	1-21/32"	31/64"	\$6.26
C65NF0326	C66NF0326	C67NF0326	9/16"-18 NF	4	H3	3-19/32"	1-21/32"	33/64"	\$6.26
C65NC0327	C66NC0327	C67NC0327	5/8"-11 NC	4	H3	3-13/16"	1-13/16"	17/32"	\$8.03
C65NF0328	C66NF0328	C67NF0328	5/8"-18 NF	4	H3	3-13/16"	1-13/16"	37/64"	\$8.03
C65NC0331	C66NC0331	C67NC0331	3/4"-10 NC	4	H3	4-1/4"	2"	21/32"	\$9.46
C65NF0332	C66NF0332	C67NF0332	3/4"-16 NF	4	H3	4-1/4"	2"	11/16"	\$9.46
C65NC0333	C66NC0333	C67NC0333	7/8"-9 NC	4	H4	4-11/16"	2-7/32"	49/64"	\$14.43
C65NF0334	C66NF0334	C67NF0334	7/8"-14 NF	4	H4	4-11/16"	2-7/32"	13/16"	\$14.43
C65NC0335	C66NC0335	C67NC0335	1"-8 NC	4	H4	5-1/8"	2-1/2"	7/8"	\$18.23
C65NF0336	C66NF0336	C67NF0336	1"-12 NF	4	H4	5-1/8"	2-1/2"	59/64"	\$18.23
C65NC0337	C66NC0337	C67NC0337	1"-14 NS	4	H4	5-1/8"	2-1/2"	15/16"	\$18.23
C65NC0338	C66NC0338	C67NC0338	1-1/8"-7 NC	4	H4	5-7/16"	2-9/16"	63/64"	\$32.33
C65NC0340	C66NC0340	C67NC0340	1-1/4"-7 NC	4	H4	5-3/4"	2-9/16"	1-7/64"	\$42.90
C65NC0342	C66NC0342	C67NC0342	1-3/8"-6 NC	4	H4	6-1/16"	3"	1-7/32"	\$58.16
C65NC0344	C66NC0344	C67NC0344	1-1/2"-6 NC	4	H4	6-3/8"	3"	1-11/32"	\$66.56



5 PCS. PER PACK
FROM 4-40 TO
1/2"-20.
SOLD INDIVIDUALLY
OVER 1/2"-20.

MAIN OFFICE

INTERNATIONAL TOOL MANUFACTURING
71-08 51ST. AVENUE, WOODSIDE, NY 11377
(718) 446-0711 • (800) 247-5696 • FAX (718) 899-6553



INTERNATIONAL TOOL MANUFACTURING
675-E-PROGRESS CENTER AVE., LAWRENCEVILLE, GA 30043
(770) 962-5454 • (800) 229-1776 • FAX (770) 962-5869

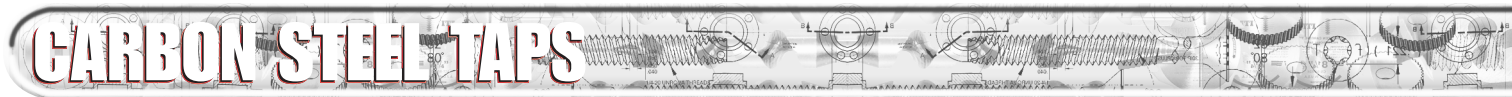

- Carbon Steel Taps.
- HSS Drill Bits.
- Ground Thread.



TAP & DRILL SET

19 PC. SET NC CARBON STEEL THREAD

PART NUMBER	DESCRIPTION	PRICE EACH
CD-SP-019	<u>19 PC. CARBON TAPS & GENERAL PURPOSE DRILLS</u>	\$51.55
6-32	5/16"-18 #36 #F	
8-32	3/8"-16 #29 5/16"	
10-24	7/16"-14 #25 #U	
10-32	1/2"-13 #21 27/64"	
1/4"-20	#7	

- NPT
- Carbon Steel.
- Ground Thread.
- Top Quality.

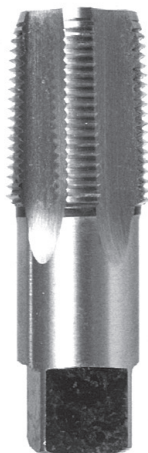

TAPER PIPE TAPS - NPT

SERIES NPT CARBON STEEL

PART NUMBER	SIZE	THREADS PER INCH NPT ONLY	No. OF FLUTES	O/A LENGTH	THREAD LENGTH	PRICE EACH
NPT0464	1/16"	27	4	2-1/8"	11/16"	\$6.25
NPT0864	1/8"	27	4	2-1/8"	3/4"	\$6.25
NPT1664	1/4"	18	4	2-7/16"	1-1/16"	\$7.42
NPT2464	3/8"	18	4	2-9/16"	1-1/16"	\$9.90
NPT3264	1/2"	14	4	3-1/8"	1-3/8"	\$17.31
NPT4864	3/4"	14	5	3-1/4"	1-3/8"	\$24.18
NPT6464	1"	11.5"	5	3-3/4"	1-3/4"	\$41.75
NPT8864	1-1/4"	11.5"	5	4"	1-3/4"	\$57.98
NPT9664	1-1/2"	11.5"	7	4-1/4"	1-3/4"	\$76.07
NPT9964	2"	11.5"	7	4-1/2"	1-3/4"	\$119.06



NPT Tap-Drill Chart Available on Page 117.

SOLD INDIVIDUALLY IN PLASTIC BOXES



T-HANDLE TAP WRENCH

PART NUMBER	O.D. SIZE	PRICE EACH
271TT0001	#0 - 1/4"	\$8.40
271TT0002	#10 - 1/2"	\$9.00



ADJUSTABLE TAP REAMER WRENCH

PART NUMBER	O.D. SIZE	SIZE	PRICE EACH
270TW0000	#0-1/4"	TW0	\$10.09
270TW0004	#0-3/8"	TW4	\$14.16
270TW0005	#7-1/2"	TW5	\$16.99
270TW0006	#7-3/4"	TW6	\$21.71
270TW0007	1/4" → 1-1/8"	TW7	\$36.43



Wrenches will accommodate all HSS & Carbon Hand Taps within O.D. size. O.D. Size = Actual Tap Size (machine screw thread).

MAIN OFFICE

INTERNATIONAL TOOL MANUFACTURING
71-08 51ST. AVENUE, WOODSIDE, NY 11377
(718) 446-0711 • (800) 247-5696 • FAX (718) 899-6553



INTERNATIONAL TOOL MANUFACTURING
675-E-PROGRESS CENTER AVE., LAWRENCEVILLE, GA 30043
(770) 962-5454 • (800) 229-1776 • FAX (770) 962-5869

COUNTER SINKS / SCREW EXTRACTORS

SINGLE FLUTE COUNTER SINKS - HSS

60(Degree) PART #	82(Degree) PART #	90(Degree) PART #	100(Degree) PART #	SIZE	SHANK DIAMETER	SHANK LENGTH	OVERALL LENGTH	PRICE EACH
CI-60-1264	CI-82-1264	CI-90-1264	CI-100-1264	3/16"	3/16"	3/4"	1-1/2"	\$8.55
CI-60-1664	CI-82-1664	CI-90-1664	CI-100-1664	1/4"	1/4"	3/4"	2"	\$9.06
CI-60-2064	CI-82-2064	CI-90-2064	CI-100-2064	5/16"	1/4"	1"	2"	\$9.73
CI-60-2464	CI-82-2464	CI-90-2464	CI-100-2464	3/8"	1/4"	1"	2"	\$10.33
CI-60-3264	CI-82-3264	CI-90-3264	CI-100-3264	1/2"	1/4"	1"	2"	\$13.30
CI-60-4064	CI-82-4064	CI-90-4064	CI-100-4064	5/8"	3/8"	1-1/8"	2-3/4"	\$18.27
CI-60-4864	CI-82-4864	CI-90-4864	CI-100-4864	3/4"	3/8"	1-5/16"	2-3/4"	\$24.44
CI-60-5064	CI-82-5064	CI-90-5064	CI-100-5064	7/8"	1/2"	1-5/16"	2-3/4"	\$33.12
CI-60-6464	CI-82-6464	CI-90-6464	CI-100-6464	1"	1/2"	1-5/16"	2-3/4"	\$41.88

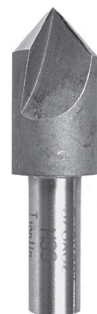

3 FLUTE COUNTERSINKS - HSS

60(Degree) PART #	82(Degree) PART #	90(Degree) PART #	100(Degree) PART #	SIZE	SHANK DIAMETER	SHANK LENGTH	OVERALL LENGTH	PRICE EACH
R3-60-1664	R3-82-1664	R3-90-1664	R3-100-1664	1/4"	3/16"	3/4"	1-1/2"	\$7.65
R3-60-2464	R3-82-2464	R3-90-2464	R3-100-2464	3/8"	1/4"	7/8"	2-3/4"	\$9.21
R3-60-3264	R3-82-3264	R3-90-3264	R3-100-3264	1/2"	3/8"	1"	2"	\$12.62
R3-60-4064	R3-82-4064	R3-90-4064	R3-100-4064	5/8"	3/8"	1"	2-1/4"	\$17.16
R3-60-4864	R3-82-4864	R3-90-4864	R3-100-4864	3/4"	1/2"	1-1/4"	2-5/8"	\$21.38
R3-60-6464	R3-82-6464	R3-90-6464	R3-100-6464	1"	1/2"	1-1/4"	2-3/4"	\$33.86



5 FLUTE COUNTERSINKS - HSS

PART #	SIZE	SHANK DIAMETER	DEGREE	PRICE EACH
5MCS00012	1/2"	1/4"	82°	\$14.94
5MCS00058	5/8"	1/4"	82°	\$17.24
5MCS00034	3/4"	1/4"	82°	\$19.54

• Milled and precision ground to countersink into any machinable material:

- Iron
- Steel
- Soft Metals
- Plastic
- Wood

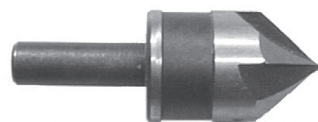

Industrial Quality

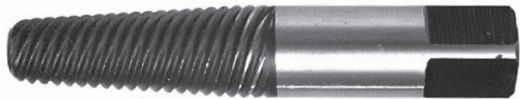

SCREW EXTRACTORS - LEFT HAND SPIRAL FLUTE

PART NUMBER	SIZE	USE DRILL	REMOVES SCREW or PIPE	PRICE EACH
SE0001	1	5/64"	3/32" to 5/32"	\$1.26
SE0002	2	7/64"	5/32" to 7/32"	\$1.34
SE0003	3	5/32"	7/32" to 9/32"	\$1.91
SE0004	4	1/4"	9/32" to 3/8", 1/8" Pipe	\$1.94
SE0005	5	19/64"	3/8" to 5/8", 1/4" Pipe	\$2.52
SE0006	6	13/32"	5/8" to 7/8", 3/8" Pipe	\$6.29
SE0007	7	17/32"	7/8" to 1-1/8", 1/2" Pipe	\$9.62
SE0008	8	13/16"	1-1/8" to 1-3/8", 3/4" Pipe	\$19.82
SE0009	9	1-1/16"	1-3/8" to 2", 1" Pipe	\$28.86



Part # SE-006-16
6 Pc. Screw Extractor Set
#1, #2, #3, #4, #5, #6
Price Each \$14.20

MAIN OFFICE

INTERNATIONAL TOOL MANUFACTURING
71-08 51ST. AVENUE, WOODSIDE, NY 11377
(718) 446-0711 • (800) 247-5696 • FAX (718) 899-6553



INTERNATIONAL TOOL MANUFACTURING
675-E-PROGRESS CENTER AVE., LAWRENCEVILLE, GA 30043
(770) 962-5454 • (800) 229-1776 • FAX (770) 962-5869

SPADE POINT / BRAD POINT DRILLS

WING TIP

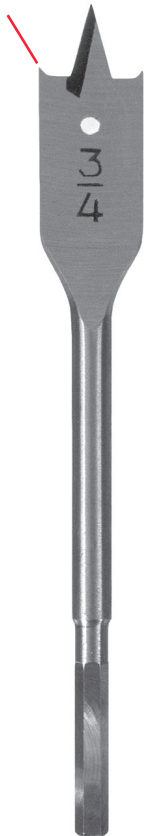

ALL SPADE POINT POWER DRILL BITS ARE SOLD INDIVIDUALLY. 1 PER POUCH.

**6" LONG SPADE BIT
POWER DRILLS FOR WOOD**

SERIES 300SB INDIVIDUALLY POUCHED

PART NUMBER	DRILL SIZE	O/A LENGTH	PRICE EACH
300SB1664	1/4"	6"	\$2.97
300SB2064	5/16"	6"	\$2.97
300SB2464	3/8"	6"	\$2.97
300SB2864	7/16"	6"	\$2.97
300SB3264	1/2"	6"	\$2.97
300SB3664	9/16"	6"	\$3.53
300SB4064	5/8"	6"	\$3.53
300SB4464	11/16"	6"	\$3.53
300SB4864	3/4"	6"	\$3.53
300SB5264	13/16"	6"	\$3.53
300SB5664	7/8"	6"	\$3.67
300SB6064	15/16"	6"	\$3.67
300SB6464	1"	6"	\$3.67
300SB7264	1-1/8"	6"	\$5.32
300SB8064	1-1/4"	6"	\$5.32
300SB8864	1-3/8"	6"	\$5.32
300SB9664	1-1/2"	6"	\$5.32

- Cold Forged
- Full Length Treated
- Machine Finish Cutting Groove
- Rust Protection
- Wing Tip Design
- Precision Ground HEX Shank

- Individually Stamped With Size
- Industrial Quality

Part # 300-ST-06
6 Pc. Spade Bit Set
3/8"- 1/2"- 5/8"- 3/4"- 7/8"- 1"
List Price Each \$16.96

**16" LONG SPADE BIT
POWER DRILLS FOR WOOD**

SERIES 301SB INDIVIDUALLY POUCHED

PART NUMBER	DRILL SIZE	O/A LENGTH	PRICE EACH
301SB1664	1/4"	16"	\$8.10
301SB2464	3/8"	16"	\$8.10
301SB3264	1/2"	16"	\$8.10
301SB4064	5/8"	16"	\$8.43
301SB4864	3/4"	16"	\$8.43
301SB5664	7/8"	16"	\$9.71
301SB6464	1"	16"	\$9.71
301SB8864	1-3/8"	16"	\$10.67

Extension For Spade Bit

307BT1214 12" Extension \$12.10



- Precision Ground
- Center Spur
- Two Shoulder Cutting Spurs
- Fluted Bit
- Industrial Quality
- Made In France

**PACKAGED
1 PER PACK**



**BRAD POINT
DRILL BITS FOR WOOD**

SERIES 309BP

PART NUMBER	DRILL SIZE	O/A LENGTH	SHANK	PRICE EACH
309BP0864	1/8"	2-1/2"	1/8"	\$1.84
309BP1064	5/32"	3-1/8"	5/32"	\$2.01
309BP1264	3/16"	3-3/8"	3/16"	\$2.05
309BP1664	1/4"	4"	1/4"	\$2.23
309BP2064	5/16"	4-5/8"	5/16"	\$2.81
309BP2464	3/8"	4-7/8"	3/8"	\$3.19
309BP2864	7/16"	5-1/2"	3/8"	\$4.52
309BP3264	1/2"	6"	3/8"	\$5.82
309BP4064	5/8"	7"	3/8"	\$8.41
309BP4864	3/4"	7-3/4"	3/8"	\$12.35
309BP5664	7/8"	8-1/8"	3/8"	\$16.95
309BP6464	1"	8-1/2"	3/8"	\$22.83



Part # 309BP007
7 Pc. Set Woodworking
1/8"- 3/16"- 1/4"- 5/16"- 3/8"-
7/16"- 1/2"
List Price Each \$25.07

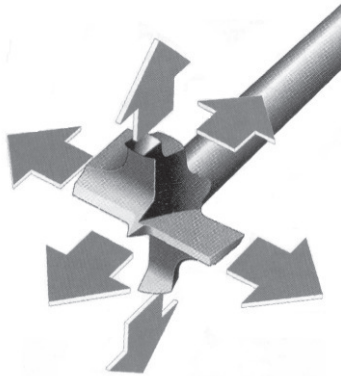

**AMAZING
 DIRECTIONAL
 CONTROL**

Unique design with six cutting edges

- Forwards
- Backwards
- Sideways
- Straight
- Curved

Saves time and money for all: Builders, Electricians, Plumbers, Joiners, Kitchen Installers, Carpenters, Locksmiths, Hobbyists, and D.I.Y.

- Drills 3X faster than Spade Drill Bits
- Drills Smooth Holes Like A Forstner Drill Bit
- Drills Irregular or Curved Holes Up to 90°
- Easy to Resharpen
- Over-All Length of All M.A.D. = 5"

Use In:

- ★ Wood
- ★ Composites
- ★ Chipboard
- ★ Plasterboard
- ★ Plastic

M.A.D. BIT

PART #	DESCRIPTION	PRICE EACH
314MA1664	1/4" M.A.D. BIT	\$8.33
314MA2464	3/8" M.A.D. BIT	\$9.75
314MA3264	1/2" M.A.D. BIT	\$12.25
314MA4064	5/8" M.A.D. BIT	\$12.75
314MA4864	3/4" M.A.D. BIT	\$13.60
314MA5664	7/8" M.A.D. BIT	\$15.75
314MA6464	1" M.A.D. BIT	\$16.75
314MA8064	1-1/4" M.A.D. BIT	\$24.50



4 PC. M.A.D. SET

PART # 314MA0004
**Multi Angle Drill
 4 Piece Set**
 SIZES 3/8", 1/2", 3/4", 1"
 Price Each Set **\$45.00**



7 PC. M.A.D. SET

PART # 314MA0007
**Multi Angle Drill
 7 Piece Set**
 SIZES 3/8", 1/2", 5/8", 3/4", 7/8"
 1", 1-1/4"
 Price Each Set **\$90.00**



MAIN OFFICE

INTERNATIONAL TOOL MANUFACTURING
71-08 51ST. AVENUE, WOODSIDE, NY 11377
(718) 446-0711 • (800) 247-5696 • FAX (718) 899-6553



INTERNATIONAL TOOL MANUFACTURING
675-E-PROGRESS CENTER AVE., LAWRENCEVILLE, GA 30043
(770) 962-5454 • (800) 229-1776 • FAX (770) 962-5869

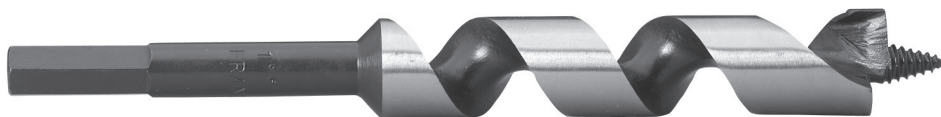
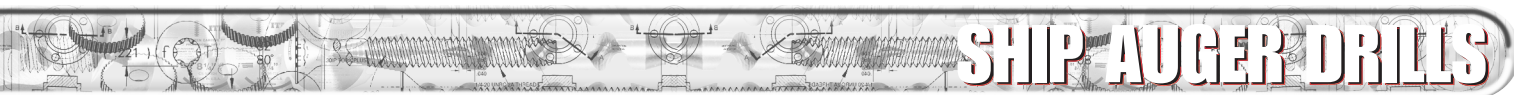

8" LONG SHIP AUGER WOOD BIT

INDIVIDUALLY POUCHED

PART NUMBER	DRILL SIZE	SIZE IN 16THS	O/A LENGTH	HEX SHANK	PRICE EACH
302SL3264	1/2"	8	8"	5/16"	\$24.84
302SL3664	9/16"	9	8"	5/16"	\$24.84
302SL4064	5/8"	10	8"	5/16"	\$24.84
302SL4464	11/16"	11	8"	5/16"	\$25.59
302SL4864	3/4"	12	8"	5/16"	\$26.37
302SL5264	13/16"	13	8"	5/16"	\$30.27
302SL5664	7/8"	14	8"	7/16"	\$31.74
302SL6064	15/16"	15	8"	7/16"	\$38.45
302SL6464	1"	16	8"	7/16"	\$39.24
302SL7264	1-1/8"	18	8"	7/16"	\$43.66
302SL8064	1-1/4"	20	8"	7/16"	\$50.58
302SL8864	1-3/8"	20	8"	7/16"	\$63.61
302SL9664	1-1/2"	24	8"	7/16"	\$65.98

- 6" Twist Length
- Heat Treated
- Machine Ground Hollows
- Deep Throat
- Single Twist
- Single Cutter
- Side Lip
- Self-Feeding Screw Point

Made in
FRANCE

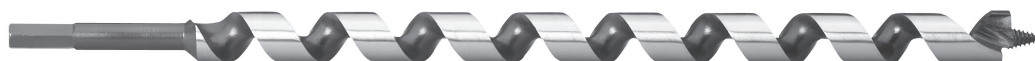

18" LONG SHIP AUGER WOOD BIT

INDIVIDUALLY POUCHED

PART NUMBER	DRILL SIZE	SIZE IN 16THS	O/A LENGTH	HEX SHANK	PRICE EACH
303SL2464	3/8"	6	18"	5/16"	\$30.54
303SL2864	7/16"	7	18"	5/16"	\$30.54
303SL3264	1/2"	8	18"	5/16"	\$30.54
303SL3664	9/16"	9	18"	7/16"	\$30.54
303SL4064	5/8"	10	18"	7/16"	\$30.54
303SL4464	11/16"	11	18"	7/16"	\$33.55
303SL4864	3/4"	12	18"	7/16"	\$33.56
303SL5264	13/16"	13	18"	7/16"	\$37.29
303SL5664	7/8"	14	18"	7/16"	\$39.03
303SL6064	15/16"	15	18"	7/16"	\$42.69
303SL6464	1"	16	18"	7/16"	\$43.37
303SL7264	1-1/8"	18	18"	7/16"	\$51.31
303SL8064	1-1/4"	20	18"	7/16"	\$59.74
303SL8864	1-3/8"	22	18"	7/16"	\$66.56
303SL9664	1-1/2"	24	18"	7/16"	\$70.45

- 12" Twist Length
- Heat Treated
- Machine Ground Hollows
- Deep Throat
- Single Twist
- Single Cutter
- Side Lip
- Self-Feeding Screw Point

Made in
FRANCE

ALL SHIP AUGER DRILL BITS ARE SOLD INDIVIDUALLY.

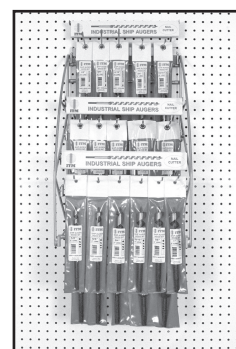

303SLDIS

46 Pcs. + Rack
Peg Board Display
\$1,523.72

Made of premium steel, Ship Auger Bits are for boring creosoted poles, railroad ties, bulkheads, and other heavy timber.



POWER BIT EXTENSIONS FOR SHIP AUGER BITS ARE ON PAGE 41.
CROSS REFERENCE CHART AVAILABLE ON 120.

MAIN OFFICE

INTERNATIONAL TOOL MANUFACTURING
71-08 51ST. AVENUE, WOODSIDE, NY 11377
(718) 446-0711 • (800) 247-5696 • FAX (718) 899-6553



INTERNATIONAL TOOL MANUFACTURING
675-E-PROGRESS CENTER AVE., LAWRENCEVILLE, GA 30043
(770) 962-5454 • (800) 229-1776 • FAX (770) 962-5869

DOUBLE TWIST WOOD DRILLS

- 8-1/2" Length
- 5-1/2" Twist Length
- Heat Treated
- Machine Ground Hollows
- Self-Feeding Screw Point
- Shank With 2 Set Screw Recesses For Use with Power Bit Extensions.

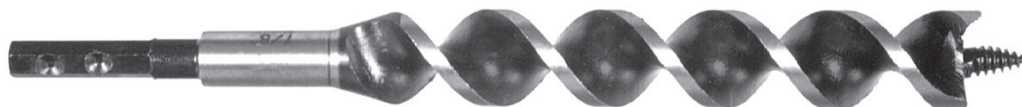

SINGLE SPUR - DOUBLE TWIST WOOD DRILLS

SERIES 304BU

These power bits are specifically designed to fit in between building studs for the installation of conduits and wires. Ideal use is with angle power drills.

Series 304BU are packaged with a rust protection sleeve. Sold Individually.

ELECTRICIAN'S POWER BITS

PART NUMBER	DRILL SIZE	O/A LENGTH	SHANK	PRICE EACH
304BU4064	5/8"	8-1/2"	5/16"	\$27.93
304BU4464	11/16"	8-1/2"	5/16"	\$28.96
304BU4864	3/4"	8-1/2"	5/16"	\$29.84
304BU5264	13/16"	8-1/2"	5/16"	\$32.14
304BU5664	7/8"	8-1/2"	7/16"	\$35.93
304BU6464	1"	8-1/2"	7/16"	\$37.66
304BU7264	1-1/8"	8-1/2"	7/16"	\$46.24
304BU8064	1-1/4"	8-1/2"	7/16"	\$52.84

- 6-1/2" Length
- 4" Twist Length
- Heat Treated
- Machine Ground Hollows
- Self-Feeding Screw Point
- Shank With 2 Set Screw Recesses For Use with Power Bit Extensions.

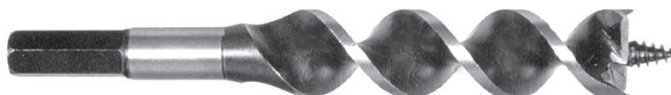

DOUBLE SPUR - DOUBLE TWIST WOOD DRILLS

SERIES 305BU

These power bits are specifically designed for boring holes where a smooth finish is required. Ideal for plumbing, heating, air conditioning, and other pipe installation.

Series 305BU are packaged with a rust protection sleeve. Sold Individually.

PLUMBER POWER BITS

PART NUMBER	DRILL SIZE	O/A LENGTH	SHANK	PRICE EACH
305BU4864	3/4"	6-1/2"	7/16"	\$30.50
305BU5664	7/8"	6-1/2"	7/16"	\$34.45
305BU6464	1"	6-1/2"	7/16"	\$38.26
305BU7264	1-1/8"	6-1/2"	7/16"	\$46.54
305BU8064	1-1/4"	6-1/2"	7/16"	\$53.04
305BU8864	1-3/8"	6-1/2"	7/16"	\$64.94
305BU9664	1-1/2"	6-1/2"	7/16"	\$72.91

MAIN OFFICE

INTERNATIONAL TOOL MANUFACTURING
71-08 51ST. AVENUE, WOODSIDE, NY 11377
(718) 446-0711 • (800) 247-5696 • FAX (718) 899-6553



INTERNATIONAL TOOL MANUFACTURING
675-E-PROGRESS CENTER AVE., LAWRENCEVILLE, GA 30043
(770) 962-5454 • (800) 229-1776 • FAX (770) 962-5869



BORE LARGE DEEP HOLES FAST...

For plumbing, rough-in work, and many other uses. Features an inside cutter that pushes the wood chips to the rear of the bit, allowing you to bore faster, deeper holes in wood, without clogging or binding.

Double-end screw point with a medium pitch screw on one end and a fine pitch screw on the other gives the operator a choice of feed speeds, depending on the work material involved.

2 recesses provided on one flat of the shank gives positive grip when used with extensions, reducing the possibility of losing the bits in hollow walls or floors.



ALL MULTISPUR & FORSTNER BITS SOLD INDIVIDUALLY

Packaged Individually With Extra Double End Screws & Wrench.

SAW TOOTH MULTISPUR WOOD DRILL BITS

SERIES 306ST

PART NUMBER	BORE DIAMETER	APPLICATIONS	SHANK	PRICE EACH
306ST0014	1-1/4"	For 3/4" Pipes	7/16"	\$37.10
306ST0000	1-3/8"	For 7/8" Pipes	7/16"	\$50.90
306ST0001	1-1/2"	For 1" Pipes	7/16"	\$50.90
306ST0002	1-3/4"	For 1-1/4" Pipes	7/16"	\$51.17
306ST0003	2-1/8"	For 1-1/2" Pipes	7/16"	\$54.52
306ST0004	2-9/16"	For 2" Pipes	7/16"	\$76.35
306ST0030	3"	For 2-1/2" Pipes	7/16"	\$83.77
306ST0005	3-5/8"	For 3" Pipes	7/16"	\$163.00
306ST0006	4-5/8"	For 4" Pipes	7/16"	\$217.23

REPLACEMENT SCREW POINTS

PART NUMBER	SIZE	FITS	PRICE EACH
SP0001	1/4"	1-1/4" to 2-9/16"	\$6.75
SP0002	1/4"	3" to 4-5/8"	\$10.13



EXTENSIONS FOR SHIP AUGERS & MULTISPUR

SERIES 307BT

PART NUMBER	DESCRIPTION	FOR SHANK	PRICE EACH
307BT1418	1/4 x 18 Extension	1/4"	\$22.08
307BT5618	5/16 x 18 Extension	5/16"	\$20.66
307BT5624	5/16 x 24 Extension	5/16"	\$28.17
307BT7609	7/16 x 9 1/2 Extensions	7/16"	\$21.69

POWER BIT EXTENSIONS

PART NUMBER	DESCRIPTION	FOR SHANK	PRICE EACH
307BT7612	7/16 x 12 Extensions	7/16"	\$21.69
307BT7618	7/16 x 18 Extensions	7/16"	\$25.14
307BT7624	7/16 x 24 Extensions	7/16"	\$31.45

- HEX Wrench included
- 2 Set Screws

MAIN OFFICE

INTERNATIONAL TOOL MANUFACTURING
71-08 51ST. AVENUE, WOODSIDE, NY 11377
(718) 446-0711 • (800) 247-5696 • FAX (718) 899-6553



INTERNATIONAL TOOL MANUFACTURING
675-E-PROGRESS CENTER AVE., LAWRENCEVILLE, GA 30043
(770) 962-5454 • (800) 229-1776 • FAX (770) 962-5869

FORSTNER WOOD DRILLS

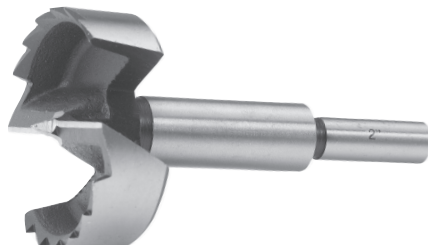
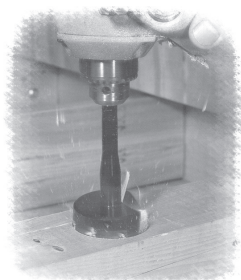

BARCODED

Sharp edges for precise holes.

FORSTNER WOOD DRILLS

SERIES 310FB

INDUSTRIAL QUALITY

3-1/2" LONG UP TO 2-1/8" DIA.
6" LONG FROM 2-1/4" DIA.

ALL FORSTNER DRILL BITS ARE SOLD INDIVIDUALLY. 1 PER PACK



- ⊙ Bores Perfectly Smooth Flat-bottomed Holes.
- ⊙ Two Cutting Edges To Clear Chips Fast.
- ⊙ Bits Will Not Shatter Thin Wood material.
- ⊙ More Accurate Holes At Any Angle.



- ⊙ All Sets: 3/8" Shanks.
- ⊙ Wood Case Protects Sharp Cutting Edges From Damage.

PART NUMBER	DRILL SIZE	SHANK	PRICE EACH
310FB1664	1/4"	3/8"	\$7.69
310FB2464	3/8"	3/8"	\$8.80
310FB3264	1/2"	3/8"	\$9.18
310FB4064	5/8"	3/8"	\$9.69
310FB4864	3/4"	3/8"	\$11.76
310FB5664	7/8"	3/8"	\$11.95
310FB6464	1"	3/8"	\$13.22
310FB7264	*1-1/8"	3/8"	\$14.16
310FB8064	*1-1/4"	3/8"	\$15.62
310FB8864	*1-3/8"	3/8"	\$20.09
310FB9664	*1-1/2"	3/8"	\$21.06
310F10464	*1-5/8"	3/8"	\$24.75

PART NUMBER	DRILL SIZE	SHANK	PRICE EACH
310F11264	*1-3/4"	3/8"	\$29.57
310F12064	*1-7/8"	3/8"	\$29.84
310F12864	*2"	3/8"	\$32.63
310F13664	*2-1/8"	3/8"	\$38.88
310F14464	*2-1/4"	1/2"	\$50.13
310F15264	*2-3/8"	1/2"	\$56.26
310F16064	*2-1/2"	1/2"	\$59.43
310F16864	*2-5/8"	1/2"	\$61.86
310F17664	*2-3/4"	1/2"	\$67.95
310F18464	*2-7/8"	1/2"	\$77.68
310F19264	*3"	1/2"	\$89.85
310F20064	*3-1/8"	1/2"	\$99.56

* Sizes 1-1/8" and Over Have Multi Spur Cutting Edge.



4" EXTENSION

PART # 310EX0100
4" Extension For Forstner Woodboring Drills For 3/8" Shanks Only!

Price Each **\$10.40**



5 PC. FORSTNER SET

PART # 310FB0005
Forstner Woodboring Drill Set 5 Piece Set
SIZES 3/4", 7/8", 1", 1-1/4", 1-3/8"

Price Each Set **\$47.19**



16 PC. FORSTNER SET

PART # 310FB0016
Forstner Woodboring Drill Set 16 Piece Set
SIZES 1/4", 3/8", 1/2", 5/8", 3/4", 7/8", 1", 1-1/8", 1-1/4", 1-3/8", 1-1/2", 1-5/8", 1-3/4", 1-7/8", 2", 2-1/8"

Price Each Set **\$135.00**

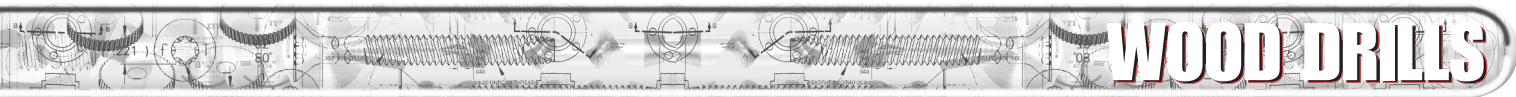

• ADJUSTABLE DEPTH



• ADJUSTABLE DEPTH



SCREW PILOTS - ROUND SHANK

SERIES 310SPR		ROUND
PART NUMBER	DESCRIPTION	PRICE EACH
310SPR006	#6 Screw Pilot Round Shank	\$4.19
310SPR008	#8 Screw Pilot Round Shank	\$4.19
310SPR010	#10 Screw Pilot Round Shank	\$4.19
310SPR012	#12 Screw Pilot Round Shank	\$4.19
310SPR4PC	4 Piece Set #6, #8, #10, #12 Round Shank	\$15.88

SCREW PILOTS - HEX SHANK

SERIES 312SPX		HEX
PART NUMBER	DESCRIPTION	PRICE EACH
312SPX006	#6 Screw Pilot HEX Shank	\$5.08
312SPX008	#8 Screw Pilot HEX Shank	\$5.08
312SPX010	#10 Screw Pilot HEX Shank	\$5.08
312SPX012	#12 Screw Pilot HEX Shank	\$5.08
312SPX4PC	4 Piece Set #6, #8, #10, #12 HEX Shank	\$19.16

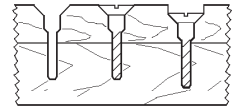

Drills, Countersinks, Counterbores in one operation. For every wood screw: Flat, Round, & Oval head.

For use with electric or hand drills on wood, plastic, or soft metal. For screw sizes #6, #8, #10, #12.

PLUG CUTTERS ROUND SHANK

SERIES 311CUT				
PART NUMBER	PLUG SIZE	CUTTING DEPTH	SHANK	PRICE EACH
311CUT014	1/4"	1"	1/4"	\$6.74
311CUT038	3/8"	1"	1/4"	\$7.29
311CUT012	1/2"	1"	1/4"	\$7.91
311CUT058	5/8"	1"	1/4"	\$8.98

PLUG CUTTERS HEX SHANK

SERIES 311HEX				
PART NUMBER	PLUG SIZE	CUTTING DEPTH	SHANK	PRICE EACH
311HEX014	1/4"	1"	1/4"	\$7.75
311HEX038	3/8"	1"	1/4"	\$8.38
311HEX012	1/2"	1"	1/4"	\$9.10
311HEX058	5/8"	1"	1/4"	\$10.33



- Precision Ground
- Hardened
- High Performance
- Solid Individually

WOOD ONLY



ELECTRICIAN'S STRETCH BITS

PART NUMBER	SIZE	APPLICATION	PRICE EACH
308FB5438	3/8" x 54" O.A.L.	Popular with alarm & communication installers for pulling light wire.	\$45.18
308FB7238	3/8" x 72" O.A.L.		\$50.32
308FB5412	1/2" x 54" O.A.L.	Popular with electricians and others for pulling heavier wire.	\$48.69
308FB7212	1/2" x 72" O.A.L.		\$53.27
308FB5496	9/16" x 54" O.A.L.	Popular with electricians and others for pulling heavier wire.	\$53.33
308FB7296	9/16" x 72" O.A.L.		\$57.25
308FB5434	3/4" x 54" O.A.L.	Popular with electricians and others for pulling heavier wire.	\$61.95
308FB7234	3/4" x 72" O.A.L.		\$65.69
308FBG	Steering Guide	Helps manipulate bits while within the wall cavity.	\$37.10
308FBDI5	Display Rack		\$137.80

Stretch Bits are constructed of a high carbon steel self-feed auger bit, permanently brazed to a flexible shaft. This tool can be inserted through small wall openings enabling the operator to bore holes through studs within the wall cavities without damaging finished walls or ceilings.

Eye Holes are provided at each end of the Stretch Bits which allow easy retrieval of wires from either direction after drilling.

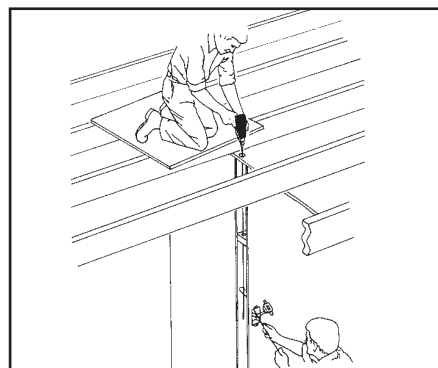

These Electrician drill bits are subject to additional shipping & handling charges.

MAIN OFFICE

INTERNATIONAL TOOL MANUFACTURING
71-08 51ST. AVENUE, WOODSIDE, NY 11377
(718) 446-0711 • (800) 247-5696 • FAX (718) 899-6553



INTERNATIONAL TOOL MANUFACTURING
675-E-PROGRESS CENTER AVE., LAWRENCEVILLE, GA 30043
(770) 962-5454 • (800) 229-1776 • FAX (770) 962-5869

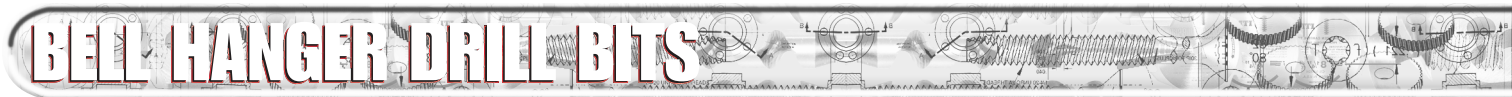

HSS BELL HANGER - FEELER BITS WITH FISH HOLES

- Fish Hole In Flute For Pulling Wire
- Special Point For Fast Drilling In Wood & Metal.
- Tapering For Quick Chip Clearance
- Suitable for
 - Telephone Installation
 - Burglar Alarms
 - Wire & Cable Applications

SERIES 308BH

BRIGHT FINISH

PART NUMBER	DRILL SIZE	O/A LENGTH	PRICE EACH
308BH1200	3/16"	12"	\$10.80
308BH1201	1/4"	12"	\$11.34
308BH1202	5/16"	12"	\$12.55
308BH1203	3/8"	12"	\$13.42
308BH1204	1/2" *	12"	\$15.22
308BH1800	3/16"	18"	\$11.50
308BH1801	1/4"	18"	\$12.50
308BH1802	5/16"	18"	\$14.05
308BH1803	3/8"	18"	\$15.31
308BH1804	1/2" *	18"	\$17.76
308BH1805	3/4" **	18"	\$24.90
308BH2401	1/4"	24"	\$15.60
308BH2402	5/16"	24"	\$18.68
308BH2403	3/8" *	24"	\$19.24
308BH2404	1/2" *	24"	\$25.12

PART NUMBER	DRILL SIZE	O/A LENGTH	PRICE EACH
308BH3001	1/4"	30"	\$18.93
308BH3003	3/8"	30"	\$21.32
308BH3004	1/2" *	30"	\$26.90
308BH4201	1/4"	42"	\$26.92
308BH4203	3/8"	42"	\$44.19
308BH4204	1/2" *	42"	\$53.40
308BH4803	3/8"	48"	\$54.36
308BH4804	1/2"	48"	\$61.31
308BH7203	3/8"	72"	\$84.13
308BH7204	1/2" *	72"	\$88.18

* 1/2" Bell Hanger Sizes Have 3/8" Shanks.
** 3/4" Bell Hanger Sizes Have 1/2" Shanks.

ALL BELL HANGER DRILL BITS ARE SOLD INDIVIDUALLY

This NEW generation of American Made Bell Hanger is made of High Speed Steel. These drill bits can drill through wood and metal.



CARBIDE BELL HANGER - FEELER BITS WITH FISH HOLES

- Fish Hole In Flute For Pulling Wire
- Special Carbide Tip For Fast Drilling In Masonry & Wood
- Suitable for Wire & Cable Applications

SERIES 308CT

BLACK FINISH

PART NUMBER	DRILL SIZE	O/A LENGTH	PRICE EACH
308CT1301	1/4"	13"	\$11.94
308CT1302	5/16"	13"	\$12.87
308CT1303	3/8"	13"	\$13.33
308CT1304	1/2" *	13"	\$14.06
308CT1305	3/4" **	13"	\$24.13
308CT1801	1/4"	18"	\$13.01
308CT1802	5/16"	18"	\$14.31
308CT1803	3/8"	18"	\$15.01
308CT1804	1/2" *	18"	\$17.82
308CT1805	3/4" **	18"	\$26.72

PART NUMBER	DRILL SIZE	O/A LENGTH	PRICE EACH
308CT2401	1/4"	24"	\$15.31
308CT2402	5/16"	24"	\$15.31
308CT2403	3/8"	24"	\$16.19
308CT2404	1/2" *	24"	\$18.86
308CT3003	3/8"	30"	\$18.45
308CT3004	1/2" *	30"	\$22.14

* 1/2" Bell Hanger Sizes Have 3/8" Shanks.
** 3/4" Bell Hanger Sizes Have 1/2" Shanks.

MAIN OFFICE

INTERNATIONAL TOOL MANUFACTURING
71-08 51ST. AVENUE, WOODSIDE, NY 11377
(718) 446-0711 • (800) 247-5696 • FAX (718) 899-6553



INTERNATIONAL TOOL MANUFACTURING
675-E-PROGRESS CENTER AVE., LAWRENCEVILLE, GA 30043
(770) 962-5454 • (800) 229-1776 • FAX (770) 962-5869

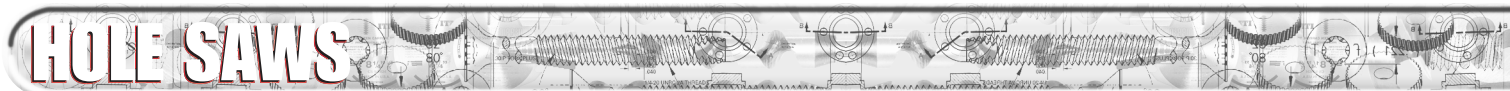

Bi-Metal Hole Saws

Variable Pitch



1 HOLE SAW PER BOX.
ARBOR NOT INCLUDED.

MADE IN THE USA

These High Quality Bi-Metal Hole Saws are made by a very special process. The cutting edge is electron beam welded to a tough alloy steel back. These hole saws are ideal for work where high performance & accuracy are needed. Saws have knock-out holes for easy core removal.

- **Made In U.S.A.**
- **Bi-Metal Construction.**
- **M3 Cutting Edge.**
- **4/6 Variable Pitch. Rc. 63-65.**
- **Positive Rake.**
- **1-1/2" Cutting Depth.**
- **Premium Quality.**
- **Cuts Through 2" x 4"s.**
- **Red Finish.**
- **Designed to Cut:**
 - Wood
 - Plastic
 - Machinable Metal
 - Nail Embedded Wood
 - Plywood
 - Pipes
 - Stainless Steel

PART NUMBER	DIA. INCHES	DIA. MM	PIPE TAP SIZE		PIPE ENT. SIZE		USE ARBOR	PRICE EACH
			INCHES	MM	INCHES	MM		
275HW0011	9/16"	14.3	3/8"				*	\$11.07
275HW0012	5/8"	15.5					*	\$11.07
275HW0112	16mm	16.0					*	\$11.07
275HW0013	11/16"	17.5					*	\$11.07
275HW0014	3/4"	19.0	1/2"	13 mm	3/8"	10 mm	*	\$11.07
275HW0114	20mm	20.0					*	\$11.07
275HW0015	13/16"	20.6					*	\$11.07
275HW0016	7/8"	22.2	3/4"	19 mm	1/2"	13 mm	*	\$11.07
275HW0017	15/16"	23.8					*	\$11.07
275HW0117	25mm	25.0					*	\$11.74
275HW0018	1"	25.4					*	\$11.74
275HW0185	1-1/16"	27.0					*	\$11.74
275HW0019	1-1/8"	28.8	1"	25 mm	3/4"	19 mm	*	\$11.74
275HW0118	30mm	30.0					*	\$11.74
275HW0020	1-3/16"	30.2					*	\$11.74
275HW0021	1-1/4"	31.8					**	\$11.74
275HW0121	32mm	32.0					**	\$11.74
275HW0022	1-5/16"	33.3					**	\$11.74
275HW0023	1-3/8"	34.9			1"	25 mm	**	\$12.45
275HW0122	35mm	35.0					**	\$12.45
275HW0123	1-7/16"	36.5					**	\$12.45
275HW0024	1-1/2"	38.1	1-1/4"	32 mm			**	\$12.69
275HW0124	1-9/16"	39.7					**	\$12.69
275HW0224	40mm	40.0					**	\$12.84
275HW0025	1-5/8"	41.2					**	\$12.84
275HW0125	1-11/16"	42.9					**	\$12.84
275HW0026	1-3/4"	44.5	1-1/2"	38 mm	1-1/4"	32 mm	**	\$15.55
275HW0226	45mm	45.0					**	\$15.55
275HW0126	1-13/16"	46.0					**	\$15.55
275HW0027	1-7/8"	47.6					**	\$15.78
275HW0127	50mm	50.0					**	\$16.01
275HW0028	2"	50.8			1-1/2"	38 mm	**	\$16.01
275HW0128	2-1/16"	52.4					**	\$19.13
275HW0029	2-1/8"	53.9					**	\$19.13
275HW0129	55mm	55.0					**	\$19.13
275HW0030	2-1/4"	57.2	2"	51 mm			**	\$19.28
275HW0031	2-5/16"	58.7					**	\$19.45
275HW0032	2-3/8"	60.3					**	\$19.55
275HW0033	2-1/2"	63.5			2"	51 mm	**	\$20.62
275HW0034	2-9/16"	65.1					**	\$20.74
275HW0134	2-5/8"	66.7	2-1/2"	64 mm			**	\$21.22
275HW0234	68mm	68.0					**	\$21.22
275HW0334	68.5mm	68.5					**	\$21.22
275HW0135	2-3/4"	69.9					**	\$21.22
275HW0136	2-7/8"	73.0					**	\$21.22
275HW0236	75mm	75.0					**	\$21.22
275HW0035	3"	76.2			2-1/2"	64 mm	**	\$21.22
275HW0137	3-1/8"	79.4					**	\$21.44
275HW0138	3-1/4"	82.6	3"	76 mm			**	\$21.44
275HW0139	3-3/8"	85.7					**	\$21.44
275HW0036	3-1/2"	88.9					**	\$21.44
275HW0140	3-5/8"	92.1			3"	76 mm	**	\$21.44
275HW0141	3-3/4"	95.3	3-1/2"	89 mm			**	\$21.44
275HW0142	3-7/8"	98.4					**	\$27.32
275HW0100	100mm	100.0					**	\$31.23
275HW0037	4"	101.6					**	\$31.23
275HW0143	4-1/8"	104.8			3-1/2"	89 mm	**	\$33.40
275HW0144	4-1/4"	108.0	4"	102 mm			**	\$41.91
275HW0038	4-1/2"	114.3			4"	102 mm	**	\$57.82
275HW0145	4-3/4"	120.7					**	\$74.03
275HW0039	5"	127.0					**	\$76.97
275HW0040	5-1/2"	139.7					**	\$89.64
275HW0146	5-3/4"	146.0					**	\$98.83
275HW0041	6"	152.4					**	\$104.92

* USE ARBORS 276AR0001 or 276AR0002.
** USE ARBORS 276AR0003 or 276AR0035.

MAIN OFFICE

INTERNATIONAL TOOL MANUFACTURING
71-08 51ST. AVENUE, WOODSIDE, NY 11377
(718) 446-0711 • (800) 247-5696 • FAX (718) 899-6553



INTERNATIONAL TOOL MANUFACTURING
675-E-PROGRESS CENTER AVE., LAWRENCEVILLE, GA 30043
(770) 962-5454 • (800) 229-1776 • FAX (770) 962-5869

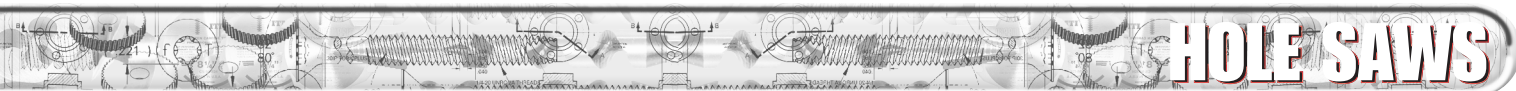

BI-METAL

**PART # 275AV02E
ELECTRICIAN'S HOLE SAW KIT**

8 Pc. Set contains:
1 each 7/8" - 1-1/8" - 1-3/8" - 1-3/4" - 2" - 2-1/2"
2 Arbors - 276AR0002 - 276AR0003

PRICE EACH \$129.15

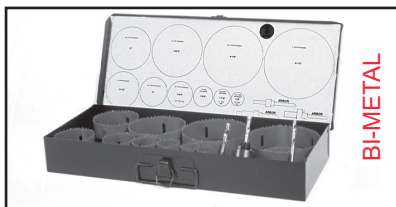

BI-METAL

**PART # 275AV08E
MASTER ELECTRICIAN'S HOLE SAW KIT**

13 Pc. Set contains:
1 each 7/8" - 1-1/8" - 1-3/8" - 1-3/4" - 2" - 2-1/2"
3" - 3-5/8" - 4-1/8" - 4-1/2"
3 Arbors - 276AR0001 - 276AR0002 - 276AR0003

PRICE EACH \$261.98



BI-METAL

**PART # 275AV04P
PLUMBER'S HOLE SAW KIT**

8 Pc. Set contains:
1 each 3/4" - 7/8" - 1-1/8" - 1-1/2" - 1-3/4" - 2-1/4"
2 Arbors - 276AR0002 - 276AR0003

PRICE EACH \$124.34

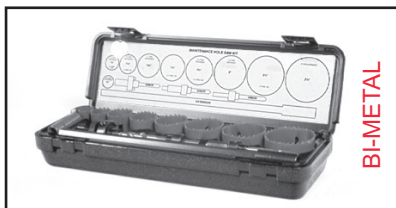

BI-METAL

**PART # 275AV100
MAINTENANCE HOLE SAW KIT**

13 Pc. Set contains:
1 each 3/4" - 7/8" - 1-1/8" - 1-3/8" - 1-1/2" - 1-3/4"
2" - 2-1/4" - 2-1/2"
3 Arbors - 276AR0001 - 276AR0002 - 276AR0003
1 Extension.

PRICE EACH \$175.60

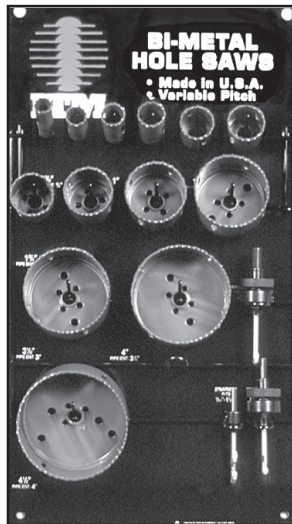

INCLUDES:

- 3/4"
- 7/8"
- 1"
- 1-1/8"
- 1-3/8"
- 1-1/2"
- 1-3/4"
- 2"
- 2-1/2"
- 3"
- 3-1/2"
- 4"
- 4-1/2"
- 3 Arbors. → 276AR0001, 276AR0003, 276AR0035

PART # 275HWDIS
13 Pieces Bi-Metal
Hole Saw Display
With 3 Arbors
PRICE EACH \$252.83

All Hole Saw Kits & Accessories
MADE IN THE USA

**RECOMMENDED
Bi-Metal HOLE SAW
CUTTING SPEEDS IN RPM's**



LUBRICANTS - Use a good cutting oil for faster, more efficient cutting in ferrous metals. Cutting oil should not be used when cutting cast iron. Beeswax or paraffin is often used when cutting aluminum.

CUTTING POSITION - Do not cut materials at an angle. All the hole saw teeth should be in contact with the material to avoid tooth damage.

FEEDS - For effective cutting, apply level and even pressure. Excessive pressure results in premature wear, dulling of the teeth, and breakage. When cutting material over 1" thick, the saw should be pulled back at

**BI-METAL HOLE SAW CROSS
REFERENCE CHART AVAILABLE
ON PAGE 119.**

SIZE	MILD STEEL	CAST IRON	TOOL & STAINLESS	BRASS	ALUMINUM
9/16"	580	400	300	790	900
5/8"	550	365	275	730	825
11/16"	500	330	250	665	750
3/4"	460	300	230	600	690
13/16"	425	280	210	560	635
7/8"	390	260	195	520	585
15/16"	370	245	185	495	555
1"	350	235	175	470	525
1 - 1/16"	325	215	160	435	480
1 - 1/8"	300	200	150	400	450
1 - 3/16"	285	190	145	380	425
1 - 1/4"	275	180	140	360	410
1 - 5/16"	260	175	135	345	390
1 - 3/8"	250	165	125	330	375
1 - 7/16"	240	160	120	315	360
1 - 1/2"	230	150	115	300	345
1 - 9/16"	220	145	110	290	330
1 - 5/8"	210	140	105	280	315
1 - 11/16"	205	135	100	270	305
1 - 3/4"	195	130	95	260	295
1 - 13/16"	190	125	95	250	285
1 - 7/8"	180	120	90	240	270
2"	170	115	85	230	255
2 - 1/16"	165	110	80	220	245
2 - 1/8"	160	105	80	210	240
2 - 1/4"	150	100	75	200	225
2 - 5/16"	145	100	75	195	225
2 - 3/8"	140	95	70	190	220
2 - 1/2"	135	90	65	180	205
2 - 9/16"	130	85	65	175	200
2 - 5/8"	130	85	65	170	195
2 - 3/4"	125	80	60	160	185
2 - 7/8"	120	80	60	160	180
3"	115	75	55	150	170
3 - 1/8"	110	70	55	140	165
3 - 1/4"	105	70	50	140	155
3 - 3/8"	100	65	50	130	150
3 - 1/2"	95	65	45	130	145
3 - 5/8"	95	60	45	120	140
3 - 3/4"	90	60	45	120	135
3 - 7/8"	90	60	45	120	135
4"	85	55	40	110	130
4 - 1/8"	80	55	40	110	120
4 - 1/4"	80	55	40	110	120
4 - 1/2"	75	50	35	100	105
4 - 3/4"	75	50	35	95	95
5"	65	45	30	90	90
5 - 1/2"	60	40	25	85	85
5 - 3/4"	55	35	25	75	75
6"	55	35	25	75	75

MAIN OFFICE

INTERNATIONAL TOOL MANUFACTURING
71-08 51ST. AVENUE, WOODSIDE, NY 11377
(718) 446-0711 • (800) 247-5696 • FAX (718) 899-6553



INTERNATIONAL TOOL MANUFACTURING
675-E-PROGRESS CENTER AVE., LAWRENCEVILLE, GA 30043
(770) 962-5454 • (800) 229-1776 • FAX (770) 962-5669

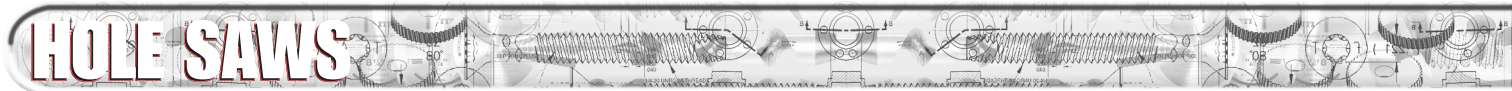

Carbide Tipped Hole Saws



MADE IN THE USA



1 HOLE SAW PER BOX.
ARBOR NOT INCLUDED.

These High Quality Carbide Tipped Hole Saws are designed for use in abrasive materials such as particle board, fiberglass, cast iron, asbestos board, and formica. They are ideal for work where high performance & accuracy are needed. Saws have knock-out holes for easy core removal.

- **Made In U.S.A.**
- Tungsten Carbide Teeth.
- Ground & Welded Set Teeth.
- 3 Teeth Per Inch.
- High Wear Resistance.
- 1-1/2" Cutting Depth.
- Premium Quality.
- Cuts Material Bi-Metal will not Cut.
- Black Finish.
- Designed to Cut:
 - Particle Board
 - Fiberglass
 - Cast Iron
 - Asbestos Board
 - Formica

PART NUMBER	DIA. INCHES	DIA. MM	PIPE ENT. SIZE		USE ARBOR	PRICE EACH
			INCHES	MM		
AT120034	3/4"	19.0	3/8"	10 mm	*	\$17.24
AT131316	13/16"	20.6			*	\$16.87
AT140078	7/8"	22.2	1/2"	13 mm	*	\$17.38
AT151516	15/16"	23.8			*	\$18.03
AT160001	1"	25.4			*	\$18.54
AT171116	1-1/16"	27.0			*	\$19.19
AT180118	1-1/8"	28.8	3/4"	19 mm	*	\$19.65
AT191316	1-3/16"	30.2			*	\$20.35
AT200114	1-1/4"	31.8			**	\$20.44
AT211516	1-5/16"	33.3			**	\$20.58
AT220138	1-3/8"	34.9	1"	25 mm	**	\$20.76
AT231716	1-7/16"	36.5			**	\$20.81
AT240112	1-1/2"	38.1			**	\$21.27
AT251916	1-9/16"	39.7			**	\$22.06
AT260158	1-5/8"	41.2			**	\$22.57
AT271116	1-11/16"	42.9			**	\$23.08
AT280134	1-3/4"	44.5	1-1/4"	32 mm	**	\$23.64
AT291316	1-13/16"	46.0			**	\$24.15
AT300178	1-7/8"	47.6			**	\$24.66
AT320002	2"	50.8	1-1/2"	38 mm	**	\$25.35
AT332116	2-1/16"	52.4			**	\$29.34
AT340218	2-1/8"	53.9			**	\$29.85
AT360214	2-1/4"	57.2			**	\$30.87
AT372516	2-5/16"	58.7			**	\$31.47
AT380238	2-3/8"	60.3			**	\$31.89
AT400212	2-1/2"	63.5	2"	51 mm	**	\$33.37
AT412916	2-9/16"	65.1			**	\$33.93
AT420258	2-5/8"	66.7			**	\$33.44
AT440234	2-3/4"	69.9			**	\$35.50
AT460278	2-7/8"	73.0			**	\$36.57
AT480003	3"	76.2	2-1/2"	64 mm	**	\$37.59
AT500318	3-1/8"	79.4			**	\$45.24
AT520314	3-1/4"	82.6			**	\$46.44
AT540338	3-3/8"	85.7			**	\$49.36
AT560312	3-1/2"	88.9			**	\$50.01
AT580358	3-5/8"	92.1	3"	76 mm	**	\$51.08
AT600334	3-3/4"	95.3			**	\$52.51
AT620378	3-7/8"	98.4			**	\$53.53
AT640004	4"	101.6			**	\$55.81
AT660418	4-1/8"	104.8	3-1/2"	89 mm	**	\$77.50
AT680414	4-1/4"	108.0			**	\$80.28
AT700438	4-3/8"	111.0			**	\$81.30
AT720412	4-1/2"	114.3	4"	102 mm	**	\$81.72
AT760434	4-3/4"	120.7			**	\$88.99
AT800005	5"	127.0			**	\$91.59
AT880512	5-1/2"	139.7			**	\$96.45
AT920534	5-3/4"	146.0			**	\$106.03
AT960006	6"	152.4			**	\$112.42



**PART # 275AT100
CARBIDE TIPPED
MAINTENANCE HOLE SAW KIT**

13 Pc. Set contains:
1 each 3/4" - 7/8" - 1-1/8" - 1-3/8" - 1-1/2" - 1-3/4"
2" - 2-1/4" - 2-1/2"
3 each Arbors for above sizes. 1 Extension.

PRICE EACH \$344.91

CARBIDE TIPPED RPM CHART

SIZE	ALUMINUM	PLASTIC	FIBER-GLASS	CERAMIC TILE	PARTICLE BOARD	CAST IRON	FORMICA
3/4"	1700	3430	250	500	3430	410	210
7/8"	1500	2940	210	430	2940	350	180
1"	1300	2570	190	370	2570	310	150
1-1/8"	1100	2290	170	330	2290	270	140
1-3/8"	900	1870	140	270	1870	220	110
1-1/2"	900	1710	120	250	1710	210	100
1-3/4"	700	1470	110	210	1470	180	90
2"	600	1290	90	190	1290	150	80
2-1/4"	600	1140	80	170	1140	140	70
2-1/2"	500	1030	70	150	1030	120	60
3"	400	860	60	120	860	100	50
3-1/4"	400	790	60	110	790	90	50
3-5/8"	400	710	50	100	710	90	40
3-3/4"	300	690	50	100	690	80	40
4-1/8"	300	620	50	90	620	70	40
4-3/4"	300	540	40	80	540	60	30
5"	200	480	40	80	500	60	30
5-1/2"	200	420	40	70	460	50	30
6"	100	360	30	60	420	40	30

* USE ARBORS 276AR0001 or 276AR0002.
** USE ARBORS 276AR0003 or 276AR0035.

MAIN OFFICE

INTERNATIONAL TOOL MANUFACTURING
71-08 51ST. AVENUE, WOODSIDE, NY 11377
(718) 446-0711 • (800) 247-5696 • FAX (718) 899-6553



INTERNATIONAL TOOL MANUFACTURING
675-E-PROGRESS CENTER AVE., LAWRENCEVILLE, GA 30043
(770) 962-5454 • (800) 229-1776 • FAX (770) 962-5869

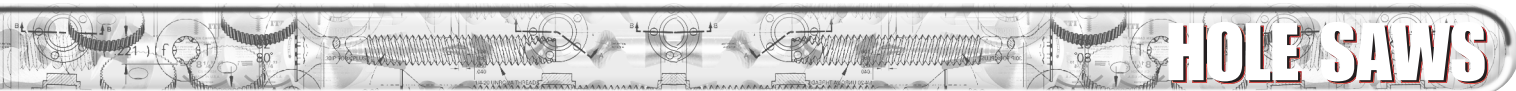

PART NUMBER	DIA. INCHES	DIA. MM	PIPE ENT. SIZE		USE ARBOR	PRICE EACH
			INCHES	MM		
CG0012	3/4"	19.0	3/8"	10 mm	*	\$29.98
CG0013	13/16"	20.6			*	\$29.98
CG0014	7/8"	22.2	1/2"	13 mm	*	\$29.98
CG0015	15/16"	23.8			*	\$29.98
CG0016	1"	25.4			*	\$32.76
CG0017	1-1/16"	27.0			*	\$32.76
CG0018	1-1/8"	28.8	3/4"	19 mm	*	\$32.76
CG0019	1-3/16"	30.2			*	\$32.76
CG0020	1-1/4"	31.8			**	\$33.61
CG0021	1-5/16"	33.3			**	\$33.61
CG0022	1-3/8"	34.9	1"	25 mm	**	\$33.89
CG0023	1-7/16"	36.5			**	\$33.89
CG0024	1-1/2"	38.1			**	\$33.89
CG0025	1-9/16"	39.7			**	\$33.89
CG0026	1-5/8"	41.2			**	\$33.89
CG0027	1-11/16"	42.9			**	\$33.89
CG0028	1-3/4"	44.5	1-1/4"	32 mm	**	\$41.58
CG0029	1-13/16"	46.0			**	\$41.58
CG0030	1-7/8"	47.6			**	\$41.58
CG0032	2"	50.8	1-1/2"	38 mm	**	\$41.58
CG0033	2-1/16"	52.4			**	\$41.58
CG0034	2-1/8"	53.9			**	\$49.19
CG0036	2-1/4"	57.2			**	\$49.19
CG0037	2-5/16"	58.7			**	\$49.19
CG0038	2-3/8"	60.3			**	\$49.19
CG0040	2-1/2"	63.5	2"	51 mm	**	\$55.46
CG0041	2-9/16"	65.1			**	\$55.46
CG0042	2-5/8"	66.7			**	\$55.46
CG0044	2-3/4"	69.9			**	\$55.46
CG0046	2-7/8"	73.0			**	\$55.46
CG0048	3"	76.2	2-1/2"	64 mm	**	\$67.20
CG0050	3-1/8"	79.4			**	\$67.20
CG0052	3-1/4"	82.6			**	\$67.20
CG0054	3-3/8"	85.7			**	\$67.20
CG0056	3-1/2"	88.9			**	\$71.36
CG0058	3-5/8"	92.1	3"	76 mm	**	\$76.79
CG0060	3-3/4"	95.3			**	\$83.17
CG0062	3-7/8"	98.4			**	\$85.90
CG0064	4"	101.6			**	\$88.79
CG0066	4-1/8"	104.8	3-1/2"	89 mm	**	\$94.81
CG0068	4-1/4"	108.0			**	\$99.56
CG0070	4-3/8"	111.0			**	\$104.52
CG0072	4-1/2"	114.3	4"	102 mm	**	\$109.19
CG0076	4-3/4"	120.7			**	\$116.84
CG0080	5"	127.0			**	\$125.01
CG0088	5-1/2"	139.7			**	\$133.77
CG0092	5-3/4"	146.0			**	\$133.77
CG0096	6"	152.4			**	\$133.77

Carbide Grit Hole Saws



MADE IN THE USA



1 HOLE SAW PER BOX.
ARBOR NOT INCLUDED.

These High Quality Carbide Grit Hole Saws are designed for use in hard or abrasive materials such as ceramics, fiberglass, hard woods, cast iron, & composites. They are best suited for thin materials that would strip bi-metal or carbide teeth. Saws have knock-out holes for easy core removal. Usa a carbide tipped pilot arbor when drilling ceramics.

- **Made In U.S.A.**
- Tungsten Carbide Grit.
- Bonded to Alloy Back.
- Gulletted Edge.
- Super Wear Resistance.
- 1-3/8" Cutting Depth.
- Premium Quality.
- Cuts Material Bi-Metal Cannot Cut.
- Black Finish.
- Designed to Cut:
 - Ceramics
 - Fiberglass
 - Cast Iron
 - Hard Woods
 - Composites



CARBIDE GRIT RECESSED LIGHTING HOLE SAWS

PART NUMBER	SIZE	PRICE EACH
CG0070	4-3/8"	\$104.52
CG0104	6-3/8"	\$141.23
CG0106	6-5/8"	\$141.23
CG0110	6-7/8"	\$141.23

* USE ARBORS 276AR0001, 276AR0002, or 276CT0034.
** USE ARBORS 276AR0003, 276AR0035 or 276CT0045 .

MAIN OFFICE

INTERNATIONAL TOOL MANUFACTURING
71-08 51ST. AVENUE, WOODSIDE, NY 11377
(718) 446-0711 • (800) 247-5696 • FAX (718) 899-6553



INTERNATIONAL TOOL MANUFACTURING
675-E-PROGRESS CENTER AVE., LAWRENCEVILLE, GA 30043
(770) 962-5454 • (800) 229-1776 • FAX (770) 962-5869

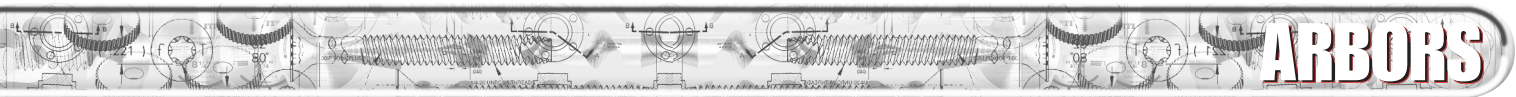

ARBORS - WITH PILOT DRILLS



- **Made In U.S.A.**
- High Quality.
- Sold Individually in White Boxes.
- Includes one 3-Flats HSS Pilot Drill.

FOR USE WITH:

- 1) Bi-Metal Hole Saws
- 2) Carbide Hole Saws
- 3) Carbide Grit Hole Saws



Use Arbors with Carbide Tipped Pilots when drilling with Carbide Tipped Hole Saws & Carbide Grit Hole Saws in:

- Particle Board
- Formica
- Tile
- Ceramics
- Fiberglass
- Granite
- Marble

PART #
276AR0001
1/4" ROUND SHANK
ARBOR FOR HOLE SAWS
9/16" → 1-3/16"
PRICE EACH \$11.14

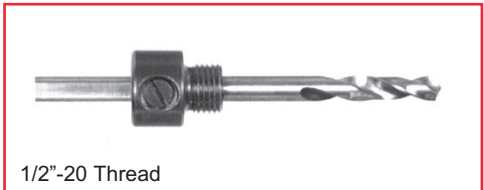

PART #
276AR0002
7/16" HEX SHANK
ARBOR FOR HOLE SAWS
9/16" → 1-3/16"
PRICE EACH \$15.48

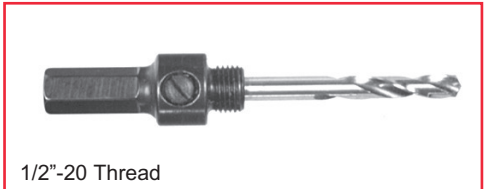

PART #
276AR0003
7/16" HEX SHANK
ARBOR FOR HOLE SAWS
1-1/4" → 6"
PRICE EACH \$24.50

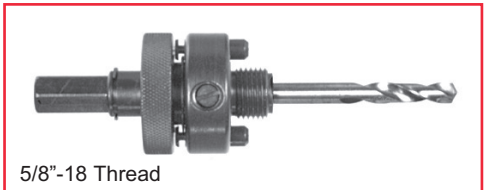

PART #
276AR0035
3/8" HEX SHANK
FOR HOLE SAWS
1-1/4" → 6"
PRICE EACH \$24.50

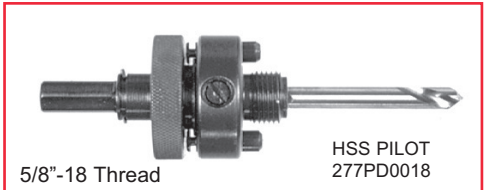

PART #
276CT0034
3/8" HEX SHANK
FOR HOLE SAWS
3/4" → 1-3/16"
PRICE EACH \$15.95

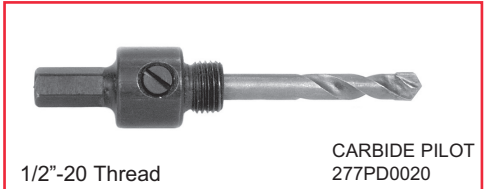

PART #
276CT0045
7/16" HEX SHANK
FOR HOLE SAWS
1-1/4" → 6"
PRICE EACH \$26.50

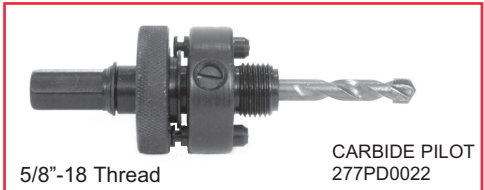

ARBOR CROSS REFERENCE CHART AVAILABLE ON PAGE 119.

MAIN OFFICE

INTERNATIONAL TOOL MANUFACTURING
71-08 51ST. AVENUE, WOODSIDE, NY 11377
(718) 446-0711 • (800) 247-5696 • FAX (718) 899-6553



INTERNATIONAL TOOL MANUFACTURING
675-E-PROGRESS CENTER AVE., LAWRENCEVILLE, GA 30043
(770) 962-5454 • (800) 229-1776 • FAX (770) 962-5869

BIMETAL RECIPROCATATING BLADES

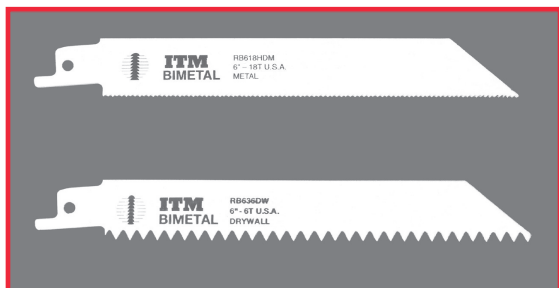

- **Made In U.S.A.**
- **1/2" Universal Shank**
- **Milled Teeth**
- **Matrix II Cutting Edge**
- **Tooth Hardness Rc 65-67**
- **8% Cobalt**
- **Vacuum Heat Treatment**
- **Long Life**
- **Shock Resistant Teeth**
- **High Edge Hardness**
- **High Heat Resistance**
- **High Wear Resistance**
- **Greater Rigidity**
- **Resists Tooth Strippage**
- **Excepts higher Feed Pressure.**



ALL PURPOSE RECIPROCATATING BLADES

PART NUMBER	BLADE LENGTH	TEETH PER INCH	DESCRIPTION	WIDTH / LENGTH	STANDARD PACK QTY.	PRICE EACH	BULK (50 Pcs.) PART NUMBER	PRICE EACH
RB636W	6"	6T	Wood & Nail Slope	3/4" x 6" x .050	5	\$3.06	BU-RB636W	\$3.01
RB656WS	6"	6T	Wood & Nail Scroll	3/4" x 6" x .050	5	\$3.17	BU-RB656WS	\$3.12
RB956W	9"	6T	Wood & Nail	3/4" x 9" x .050	5	\$4.11	BU-RB956W	\$4.06
RB125W	12"	6T	Wood & Nail	3/4" x 12" x .050	5	\$5.41	BU-RB125W	\$5.36
RB414M	4"	14T	Short Metal Cutting	5/8" x 4" x .035	5	\$1.58	BU-RB414M	\$1.52
RB418M	4"	18T	Short Metal Cutting	5/8" x 4" x .035	5	\$1.58	BU-RB418M	\$1.52
RB424M	4"	24T	Short Metal Cutting	5/8" x 4" x .035	5	\$1.58	BU-RB424M	\$1.52
RB610HDM	6"	10T	HD Metal Cutting	3/4" x 6" x .035	5	\$2.28	BU-RB610HDM	\$2.22
RB614HDM	6"	14T	HD Metal Cutting	3/4" x 6" x .035	5	\$2.28	BU-RB614HDM	\$2.22
RB618HDM	6"	18T	HD Metal Cutting	3/4" x 6" x .035	5	\$2.28	BU-RB618HDM	\$2.22
RB624HDM	6"	24T	HD Metal Cutting	3/4" x 6" x .035	5	\$2.28	BU-RB624HDM	\$2.22
RB810HDM	8"	10T	HD Metal Cutting 10/14 V.P.	3/4" x 8" x .035	5	\$3.57	BU-RB810HDM	\$3.52
RB814HDM	8"	14T	HD Metal Cutting	3/4" x 8" x .035	5	\$3.57	BU-RB814HDM	\$3.52
RB818HDM	8"	18T	HD Metal Cutting	3/4" x 8" x .035	5	\$3.57	BU-RB818HDM	\$3.52
RB1218HDM	12"	18T	HD Metal Cutting	3/4" x 12" x .035	5	\$5.41	BU-RB1218HDM	\$5.36
RB636DW	6"	6"	Drywall V Head	3/4" x 6" x .035	5	\$2.06	BU-RB636DW	\$2.01
R8CCRF	8"	CARBIDE GRIT	Cast Iron-Ceramic Tile	3/4" x 8" x .050	1	\$8.55	BU-R8CCRF	\$8.45

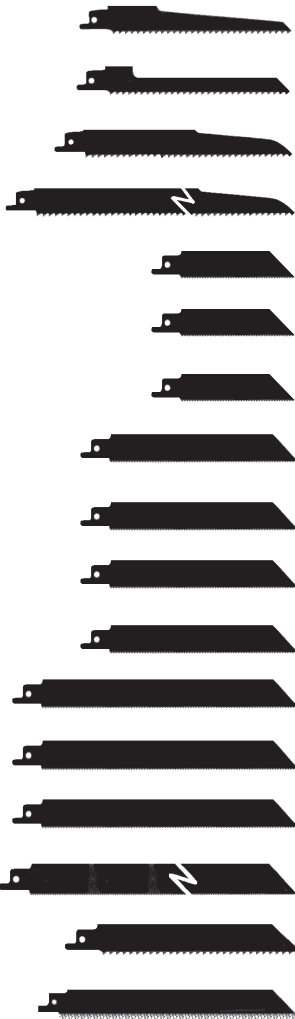

MAIN OFFICE

INTERNATIONAL TOOL MANUFACTURING
71-08 51ST. AVENUE, WOODSIDE, NY 11377
(718) 446-0711 • (800) 247-5696 • FAX (718) 899-6553



INTERNATIONAL TOOL MANUFACTURING
675-E-PROGRESS CENTER AVE., LAWRENCEVILLE, GA 30043
(770) 962-5454 • (800) 229-1776 • FAX (770) 962-5869

BI-METAL RECIPROCATING BLADES

VIGOR™

Industrial Blades are Vigorous Blades.

- **Made In U.S.A.**
- **1/2" Universal Shank**
- **45% Thicker Than All Purpose Blades**
- **Wider Than All Purpose Blades**
- **Stay Rigid**
- **No Vibration**
- **More Cuts Per Blade**

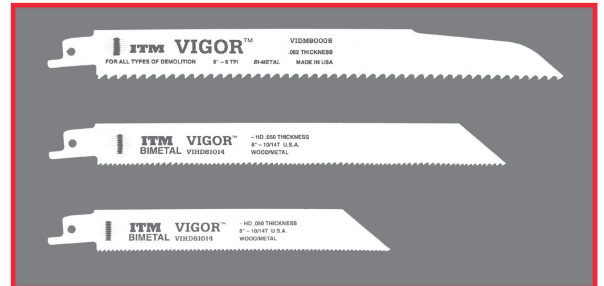

VIGOR™ HEAVY DUTY RECIPROCATING BLADES

PART NUMBER	BLADE LENGTH	TEETH PER INCH	DESCRIPTION	WIDTH / LENGTH	STANDARD PACK QTY.	PRICE EACH	BULK (50 Pcs.) PART NUMBER	PRICE EACH
VIHD61014	6"	10/14 V.P.	HEAVY DUTY	3/4" X 6" X .050	5	\$3.20	BU-VIHD61014	\$3.05
VIHD81014	8"	10/14 V.P.	HEAVY DUTY	3/4" X 8" X .050	5	\$4.38	BU-VIHD81014	\$4.18
VIHD12014	12"	10/14 V.P.	HEAVY DUTY	3/4" X 12" X .050	5	\$5.45	BU-VIHD12014	\$5.20

V.P. = Variable Pitch (Teeth)



VIGOR™ DEMOLITION RECIPROCATING BLADES

PART NUMBER	BLADE LENGTH	TEETH PER INCH	DESCRIPTION	WIDTH / LENGTH	STANDARD PACK QTY.	PRICE EACH	BULK (25 Pcs.) PART NUMBER	PRICE EACH
VIDM60006	6"	6T	DEMOLITION	7/8" X 6" X .062	3	\$5.72	BU-VIDM60006	\$5.43
VIDM60010	6"	10T	DEMOLITION	7/8" X 6" X .062	3	\$5.72	BU-VIDM60010	\$5.43
VIDM90006	9"	6T	DEMOLITION	7/8" X 9" X .062	3	\$8.15	BU-VIDM90006	\$7.75
VIDM90010	9"	10T	DEMOLITION	7/8" X 9" X .062	3	\$8.15	BU-VIDM90010	\$7.75
VIDM12006	12"	6T	DEMOLITION	7/8" X 12" X .062	3	\$9.84	BU-VIDM12006	\$9.35
VIDM12010	12"	10T	DEMOLITION	7/8" X 12" X .062	3	\$9.84	BU-VIDM12010	\$9.35

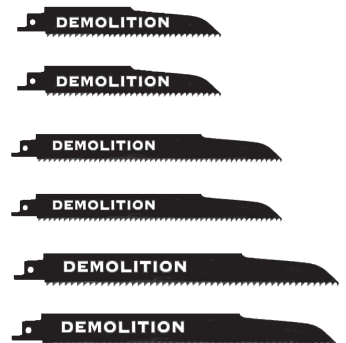

Tooth Style:



Standard beveled configuration



10/14 Variable Pitch beveled configuration

RB322

332 Pcs. + Rack
Peg Board Display
\$999.00



MAIN OFFICE

INTERNATIONAL TOOL MANUFACTURING
71-08 51ST. AVENUE, WOODSIDE, NY 11377
(718) 446-0711 • (800) 247-5696 • FAX (718) 899-6553



INTERNATIONAL TOOL MANUFACTURING
675-E-PROGRESS CENTER AVE., LAWRENCEVILLE, GA 30043
(770) 962-5454 • (800) 229-1776 • FAX (770) 962-5869

HSS MULTI-CONE DRILL BITS

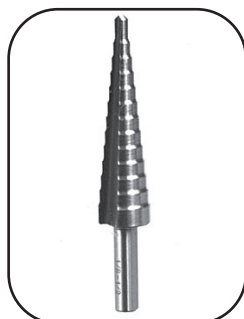

1/8"
5/32"
3/16"
7/32"
1/4"
9/32"
5/16"
11/32"
3/8"
13/32"
7/16"
15/32"
1/2"

274MC0001

13 Steps 1/8" - 1/2"
Price Each \$44.00

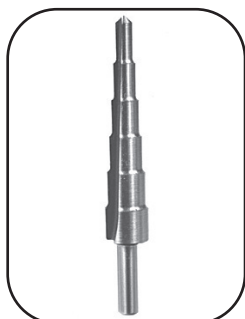

3/16"
1/4"
5/16"
3/8"
7/16"
1/2"

274MC0002

6 Steps 3/16" - 1/2"
Price Each \$42.85



1/4"
5/16"
3/8"
7/16"
1/2"
9/16"
5/8"
11/16"
3/4"

274MC0003

9 Steps 1/4" - 3/4"
Price Each \$53.27



BARCODED

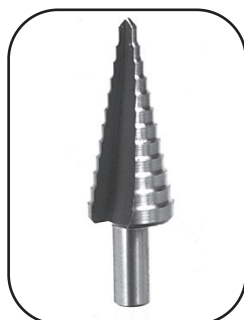

3/16"
1/4"
5/16"
3/8"
7/16"
1/2"
9/16"
5/8"
11/16"
3/4"
13/16"
7/8"

274MC0004

12 Steps 3/16" - 7/8"
Price Each \$59.58



7/16"
1/2"
9/16"
5/8"
11/16"
3/4"
13/16"
7/8"
15/16"
1"
1-1/16"
1-1/8"

274MC0005

12 Steps 7/16" - 1-1/8"
Price Each \$84.83

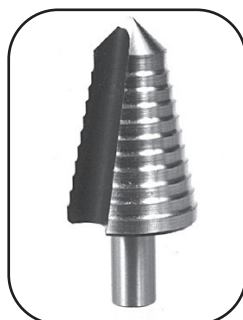

3/4"
13/16"
7/8"
15/16"
1"
1-1/16"
1-1/8"
1-3/16"
1-1/4"
1-5/16"
1-3/8"

274MC0006

11 Steps 3/4" - 1-3/8"
Price Each \$113.09

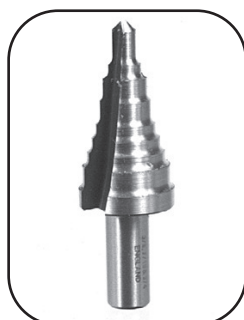

3/8"
7/16"
3/4"

For drilling 3 standard size holes to accommodate drive screws for knockout punches.

274MC0007

3 Steps 3/8" - 3/4"
Price Each \$69.42

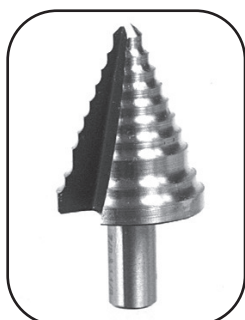

7/8"
1-1/8"

7/8" hole for 1/2" conduit.
1-1/8" hole for 3/4" conduit.

274MC0008

2 Steps 7/8" - 1-1/8"
Price Each \$82.81



7/8"
1-1/8"
1-7/32"
1-1/4"
1-3/8"

1-7/32" hole for oil tight switches.

274MC0009

5 Steps 7/8" - 1-3/8"
Price Each \$99.50

More accurate control of hole size in various sheet materials up to 1/8" thick. Each multi-cone bit drills a range of sizes. The further the bit advances, the larger the diameter of the hole gets. Because multi cone drill bits enter the material one step at a time, the operator can drill the desired hole by counting the individual steps, or by using a washer as a simple stop. The self starting tip eliminates the need for pilot holes. Applications include junction boxes, switch boxes, metal studs, electrical applications, lighting fixtures, auto body work, and many other uses.

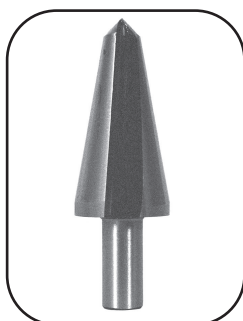

7/8"

274MC0010

1 Cone 7/8"
Price Each \$59.58

- Lobbed Non-Slip Shank.
- High Speed Steel.
- Drill Up To 1/8" Thick Material.
- Two Flutes.

- Suitable For:
 - Ferrous & Non-Ferrous Sheet Metal
 - Wood
 - Plastic Laminates
 - Sink Grade Stainless Steel
 - Maintenance
 - Electrical Contracting
 - Plumbing
 - Auto Body Repair
 - Heating
 - Air Conditioning
 - Rust Proofing

Recommended Cutting Speeds:

1/8" - 3/8"	1200RPM
3/8" - 1/2"	600 RPM
1/2" - 5/8"	400 RPM
5/8" - 3/4"	350 RPM
3/4" - 7/8"	300 RPM
1"	260 RPM
1-1/8"	240 RPM
1-1/2"	200 RPM



SOLD INDIVIDUALLY

MAIN OFFICE

INTERNATIONAL TOOL MANUFACTURING
71-08 51ST. AVENUE, WOODSIDE, NY 11377
(718) 446-0711 • (800) 247-5696 • FAX (718) 899-6553



INTERNATIONAL TOOL MANUFACTURING
675-E-PROGRESS CENTER AVE., LAWRENCEVILLE, GA 30043
(770) 962-5454 • (800) 229-1776 • FAX (770) 962-5869

INDUSTRIAL WIRE BRUSHES

PART NUMBER	SIZE	WIRE TYPE	MATERIAL	PRICE EACH
KCC075	3"	KNOTTED CUP	CARBON STEEL	\$16.14
KCS075	3"	KNOTTED CUP	STAINLESS STEEL	\$25.84
KCC100	4"	KNOTTED CUP	CARBON STEEL	\$25.15
KCC150	6"	KNOTTED CUP	CARBON STEEL	\$52.99
CCC075	3"	CRIMPED CUP	CARBON STEEL	\$16.61
CCC100	4"	CRIMPED CUP	CARBON STEEL	\$20.82
CCC125	5"	CRIMPED CUP	CARBON STEEL	\$27.42
TKW100	4"	TWIST KNOT WHEEL	CARBON STEEL	\$19.25
TKW150	6"	TWIST KNOT WHEEL	CARBON STEEL	\$27.66
SBW100	4"	STRINGER BEAD WHEEL	CARBON STEEL	\$18.36
SBS100	4"	STRINGER BEAD WHEEL	STAINLESS STEEL	\$27.86
SBW150	6"	STRINGER BEAD WHEEL	CARBON STEEL	\$25.55
WBB120	12"	WALK BEHIND WIRE BRUSH	CARBON STEEL 1" SPINDLE	\$98.25
VIP100		HAND WIRE BRUSH	CARBON STEEL	\$8.00



- 5/8" - 11 SPINDLE.
- SOLD IN RETAIL PLASTIC DOUBLE BLISTER PACK



- INDUSTRIAL QUALITY



STAINLESS STEEL BRUSHES ARE BEST FOR:

- Stainless Steel
- Aluminum
- Non-Ferrous Alloy Metals

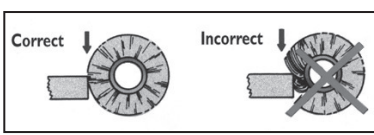

APPLICATION	KNOTTED CUP WIRE BRUSH	CRIMPED CUP WIRE BRUSH	TWIST KNOT WIRE BRUSH	STRINGER BEAD WIRE BRUSH
DEBURRING (FINE)	⊗	⊗		
DEBURRING (COARSE)			⊗	⊗
EDGE BLENDING	⊗	⊗		
WELD, SCALE REMOVAL			⊗	⊗
WELD PREP				⊗
SURFACE FINISHING	⊗	⊗		
RUST OXIDE (FINE)	⊗	⊗		
RUST OXIDE (COARSE)			⊗	⊗
PAINT REMOVAL	⊗	⊗		
ROUGHENING	⊗	⊗	⊗	⊗
CLEANING	⊗	⊗		⊗
FLASH REMOVAL		⊗	⊗	
TOOL MARK REMOVAL		⊗	⊗	
EXPANSION JOINT		⊗	⊗	

SUGGESTED RPM FOR ALL SIZES

SIZE	TYPE	RECOM. RPM	MAX RPM
3"	KNOTTED CUP	6,500	8,500
4"	KNOTTED CUP	6,500	8,500
6"	KNOTTED CUP	4,500	6,500
3"	CRIMPED CUP	5,000	8,500
4"	CRIMPED CUP	4,000	8,500
5"	CRIMPED CUP	3,200	8,500
4"	TWIST KNOT WHEEL	7,000	15,000
6"	TWIST KNOT WHEEL	5,000	9,000
4"	STRINGER BEAD WHEEL	7,000	15,000
6"	STRINGER BEAD WHEEL	5,000	9,000

MAIN OFFICE

INTERNATIONAL TOOL MANUFACTURING
71-08 51ST. AVENUE, WOODSIDE, NY 11377
(718) 446-0711 • (800) 247-5696 • FAX (718) 899-6553



INTERNATIONAL TOOL MANUFACTURING
675-E-PROGRESS CENTER AVE., LAWRENCEVILLE, GA 30043
(770) 962-5454 • (800) 229-1776 • FAX (770) 962-5869

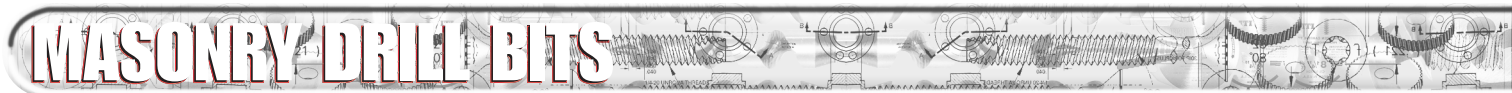

- Tungsten Carbide
- Fast Spiral
- Nickel Plated
- Suitable For:
 - Brick
 - Cement
 - Tile
 - Slate
 - Cinder Block



FAST SPIRAL POUCHED

SERIES 500FS NICKEL PLATED

PART NUMBER	DRILL SIZE	O/A LENGTH	SHANK	PRICE EACH
500FS0632	3/16"	4"	3/16"	\$1.24
500FS0832	1/4"	4"	1/4"	\$1.35
500FS1032	5/16"	4"	1/4"	\$1.69
500FS1232	3/8"	4"	1/4"	\$2.25
500FS1632	1/2"	4"	1/4"	\$3.37
500FS6832	1/4"	6"	1/4"	\$2.47
500FS7032	5/16"	6"	1/4"	\$2.98
500FS8032	3/8"	6"	1/4"	\$3.37
500FS9032	1/2"	6"	3/8"	\$3.59

FAST SPIRAL BULK

SERIES 500BU NICKEL PLATED

PART NUMBER	DRILL SIZE	O/A LENGTH	SHANK	PRICE EACH
500BU0632	3/16"	4"	3/16"	\$1.11
500BU0832	1/4"	4"	1/4"	\$1.21
500BU1032	5/16"	4"	1/4"	\$1.52
500BU1232	3/8"	4"	1/4"	\$2.02
500BU1632	1/2"	4"	1/4"	\$3.03
500BU6832	1/4"	6"	1/4"	\$2.23
500BU7032	5/16"	6"	1/4"	\$2.67
500BU8032	3/8"	6"	1/4"	\$3.03
500BU9032	1/2"	6"	3/8"	\$3.25



All Masonry Drill Bits

MADE IN THE USA

- Tungsten Carbide
- Fast Cutting
- Slow Spiral
- Nickel Plated
- Suitable For:
 - Brick
 - Cement
 - Tile
 - Slate
 - Cinder Block



SLOW SPIRAL POUCHED

SERIES 501SP NICKEL PLATED

PART NUMBER	DRILL SIZE	O/A LENGTH	SHANK	PRICE EACH
501SP4001	1/8"	3"	1/8"	\$1.24
501SP4002	3/16"	4"	3/16"	\$1.35
501SP4003	1/4"	4"	1/4"	\$1.46
501SP4004	5/16"	4"	1/4"	\$1.80
501SP4005	3/8"	4"	1/4"	\$2.42
501SP4006	1/2"	4"	1/4"	\$3.59
501SP4007	5/8"	4"	1/4"	\$6.52
501SP6001	3/16"	6"	3/16"	\$2.47
501SP6002	1/4"	6"	1/4"	\$2.59
501SP6003	5/16"	6"	1/4"	\$3.10
501SP6004	3/8"	6"	1/4"	\$3.49
501SP6005	7/16"	6"	1/4"	\$3.59
501SP6006	1/2"	6"	1/4"	\$3.71
501SP6007	1/2"	6"	3/8"	\$3.71
501SP6008	9/16"	6"	3/8"	\$5.96
501SP6009	5/8"	6"	3/8"	\$6.63
501SP6010	3/4"	6"	1/2"	\$8.49
501SP6011	7/8"	6"	1/2"	\$9.93
501SP6012	1"	6"	1/2"	\$12.14
501SP1201	1/4"	12"	1/4"	\$5.70
501SP1202	5/16"	12"	1/4"	\$6.47
501SP1203	3/8"	12"	3/8"	\$7.55
501SP1204	1/2"	12"	3/8"	\$8.59
501SP1205	5/8"	12"	3/8"	\$12.13
501SP1206	3/4"	12"	1/2"	\$15.61
501SP1207	7/8"	12"	1/2"	\$17.21
501SP1208	1"	12"	1/2"	\$20.78

SLOW SPIRAL BULK

SERIES 501BU NICKEL PLATED

PART NUMBER	DRILL SIZE	O/A LENGTH	SHANK	PRICE EACH
501BU4001	1/8"	3"	1/8"	\$1.11
501BU4002	3/16"	4"	3/16"	\$1.21
501BU4003	1/4"	4"	1/4"	\$1.31
501BU4004	5/16"	4"	1/4"	\$1.62
501BU4005	3/8"	4"	1/4"	\$2.17
501BU4006	1/2"	4"	1/4"	\$3.23
501BU4007	5/8"	4"	1/4"	\$5.86
501BU6001	3/16"	6"	3/16"	\$2.27
501BU6002	1/4"	6"	1/4"	\$2.32
501BU6003	5/16"	6"	1/4"	\$2.78
501BU6004	3/8"	6"	1/4"	\$3.14
501BU6005	7/16"	6"	1/4"	\$3.23
501BU6006	1/2"	6"	1/4"	\$3.34
501BU6007	1/2"	6"	3/8"	\$3.34
501BU6008	9/16"	6"	3/8"	\$5.36
501BU6009	5/8"	6"	3/8"	\$5.97
501BU6010	3/4"	6"	1/2"	\$7.64
501BU6011	7/8"	6"	1/2"	\$8.94
501BU6012	1"	6"	1/2"	\$10.92
501BU1201	1/4"	12"	1/4"	\$5.13
501BU1202	5/16"	12"	1/4"	\$5.81
501BU1203	3/8"	12"	3/8"	\$6.88
501BU1204	1/2"	12"	3/8"	\$7.72
501BU1205	5/8"	12"	3/8"	\$10.91
501BU1206	3/4"	12"	1/2"	\$14.06
501BU1207	7/8"	12"	1/2"	\$15.50
501BU1208	1"	12"	1/2"	\$18.71

Best when used with Rotation / Light Percussion.



MAIN OFFICE

INTERNATIONAL TOOL MANUFACTURING
71-08 51ST. AVENUE, WOODSIDE, NY 11377
(718) 446-0711 • (800) 247-5696 • FAX (718) 899-6553



INTERNATIONAL TOOL MANUFACTURING
675-E-PROGRESS CENTER AVE., LAWRENCEVILLE, GA 30043
(770) 962-5454 • (800) 229-1776 • FAX (770) 962-5869

GOLD HEAD MASONRY DRILL BITS

SLOW SPIRAL POUCHED

SERIES 502SP BLACK OXIDE

PART NUMBER	DRILL SIZE	O/A LENGTH	SHANK	PRICE EACH
502SP4001	1/8"	3"	1/8"	\$1.35
502SP4002	3/16"	4"	3/16"	\$1.48
502SP4732	7/32"	4"	7/32"	\$1.58
502SP4003	1/4"	4"	1/4"	\$1.61
502SP4004	5/16"	4"	1/4"	\$1.98
502SP4005	3/8"	4"	1/4"	\$2.65
502SP4006	1/2"	4"	1/4"	\$3.95
502SP4007	5/8"	4"	1/4"	\$7.17
502SP6001	3/16"	6"	3/16"	\$2.66
502SP6002	1/4"	6"	1/4"	\$2.84
502SP6003	5/16"	6"	1/4"	\$3.39
502SP6004	3/8"	6"	3/8"	\$3.83
502SP6005	7/16"	6"	1/4"	\$3.95
502SP6006	1/2"	6"	1/4"	\$4.08
502SP6007	1/2"	6"	3/8"	\$4.08
502SP6008	9/16"	6"	3/8"	\$6.55
502SP6009	5/8"	6"	3/8"	\$7.19
502SP6010	3/4"	6"	1/2"	\$9.34
502SP6011	7/8"	6"	1/2"	\$10.92
502SP6012	1"	6"	1/2"	\$14.47
502SP1201	1/4"	12"	1/4"	\$6.26
502SP1202	5/16"	12"	1/4"	\$7.10
502SP1203	3/8"	12"	3/8"	\$8.41
502SP1204	1/2"	12"	3/8"	\$9.43
502SP1205	5/8"	12"	3/8"	\$13.33
502SP1206	3/4"	12"	1/2"	\$16.85
502SP1207	7/8"	12"	1/2"	\$18.94
502SP1208	1"	12"	1/2"	\$21.35
502SL1814	1/4"	18"	1/4"	\$8.33
502SL1856	5/16"	18"	5/16"	\$9.35
502SL1838	3/8"	18"	3/8"	\$10.95
502SL1812	1/2"	18"	3/8"	\$12.21
502SL1858	5/8"	18"	3/8"	\$16.99
502SL1834	3/4"	18"	1/2"	\$21.71
502SL1878	7/8"	18"	1/2"	\$23.87
502SL1801	1"	18"	1/2"	\$28.69

SLOW SPIRAL BULK

SERIES 502BU BLACK OXIDE

PART NUMBER	DRILL SIZE	O/A LENGTH	SHANK	PRICE EACH
502BU4001	1/8"	3"	1/8"	\$1.24
502BU4002	3/16"	4"	3/16"	\$1.35
502BU4732	7/32"	4"	7/32"	\$1.50
502BU4003	1/4"	4"	1/4"	\$1.46
502BU4004	5/16"	4"	1/4"	\$1.78
502BU4005	3/8"	4"	1/4"	\$2.42
502BU4006	1/2"	4"	1/4"	\$3.59
502BU4007	5/8"	4"	1/4"	\$6.52
502BU6001	3/16"	6"	3/16"	\$2.47
502BU6002	1/4"	6"	1/4"	\$2.59
502BU6003	5/16"	6"	1/4"	\$3.10
502BU6004	3/8"	6"	3/8"	\$3.49
502BU6005	7/16"	6"	1/4"	\$3.59
502BU6006	1/2"	6"	1/4"	\$3.71
502BU6007	1/2"	6"	3/8"	\$3.71
502BU6008	9/16"	6"	3/8"	\$5.96
502BU6009	5/8"	6"	3/8"	\$6.63
502BU6010	3/4"	6"	1/2"	\$8.49
502BU6011	7/8"	6"	1/2"	\$9.93
502BU6012	1"	6"	1/2"	\$13.26
502BU1201	1/4"	12"	1/4"	\$5.70
502BU1202	5/16"	12"	1/4"	\$6.47
502BU1203	3/8"	12"	3/8"	\$7.64
502BU1204	1/2"	12"	3/8"	\$8.59
502BU1205	5/8"	12"	3/8"	\$12.13
502BU1206	3/4"	12"	1/2"	\$15.61
502BU1207	7/8"	12"	1/2"	\$17.21
502BU1208	1"	12"	1/2"	\$20.22
502BU1814	1/4"	18"	1/4"	\$7.70
502BU1856	5/16"	18"	5/16"	\$8.71
502BU1838	3/8"	18"	3/8"	\$10.31
502BU1812	1/2"	18"	3/8"	\$11.58
502BU1858	5/8"	18"	3/8"	\$16.36
502BU1834	3/4"	18"	1/2"	\$21.07
502BU1878	7/8"	18"	1/2"	\$23.24
502BU1801	1"	18"	1/2"	\$28.06

MOST POPULAR



- Tungsten Carbide
- Slow Spiral
- Black Oxide
- Tempered Body for Long Life
- Suitable For:
 - Brick
 - Cement
 - Tile
 - Slate
 - Cinder Block



All Masonry Drill Bits

MADE IN THE USA

These Gold Head Masonry Drill Bits are made to drill everything. The special Tungsten Carbide tip can be used for rotary drilling or for percussion.



MAIN OFFICE

INTERNATIONAL TOOL MANUFACTURING
71-08 51ST. AVENUE, WOODSIDE, NY 11377
(718) 446-0711 • (800) 247-5696 • FAX (718) 899-6553



INTERNATIONAL TOOL MANUFACTURING
675-E-PROGRESS CENTER AVE., LAWRENCEVILLE, GA 30043
(770) 962-5454 • (800) 229-1776 • FAX (770) 962-5869



BEST ROTARY PERCUSSION BITS

SERIES 700 STRAIGHT SHANK TWO TONE FINISH

PART NUMBER	DRILL SIZE	X	O/A LENGTH	DRILLING DEPTH	SHANK SIZE	PRICE EACH
700040864	1/8"	X	3"	1-1/2"	1/8"	\$2.71
700041264	3/16"	X	3-1/2"	1-3/4"	3/16"	\$2.88
700041664	1/4"	X	4"	2-1/2"	1/4"	\$2.95
700041864	9/32"	X	4"	2-1/2"	9/32"	\$3.75
700042064	5/16"	X	4-3/4"	3-1/2"	5/16"	\$3.75
6" LONG						
700061064	5/32"	X	6"	4"	5/32"	\$3.46
700061264	3/16"	X	6"	4"	3/16"	\$3.46
700061664	1/4"	X	6"	4"	1/4"	\$3.79
700062064	5/16"	X	6"	4"	5/16"	\$4.92
700062464	3/8"	X	6"	4"	3/8"	\$4.92
700062864	7/16"	X	6"	4"	3/8"	\$7.33
700063264	1/2"	X	6"	4"	3/8"	\$7.08
700063664	9/16"	X	6"	4"	Hex 3/8"	\$10.21
700064064	5/8"	X	6"	4"	Hex 3/8"	\$10.71
700064864	3/4"	X	6"	4"	Hex 1/2"	\$13.63
700065664	7/8"	X	6"	4"	Hex 1/2"	\$16.21
700066464	1"	X	6"	4"	Hex 1/2"	\$19.17
12" LONG						
700131664	1/4"	X	12"	10"	1/4"	\$7.88
700132464	3/8"	X	12"	10"	3/8"	\$9.08
700133264	1/2"	X	12"	10"	3/8"	\$13.25
700134064	5/8"	X	12"	10"	Hex 3/8"	\$16.88
700134864	3/4"	X	12"	10"	Hex 1/2"	\$19.42
700135664	7/8"	X	12"	10"	Hex 1/2"	\$26.63
700136464	1"	X	12"	10"	Hex 1/2"	\$30.67
20" LONG						
700202464	3/8"	X	20"	16"	3/8"	\$14.25
700203264	1/2"	X	20"	16"	3/8"	\$18.04
24" LONG						
700241664	1/4"	X	24"	20"	1/4"	\$15.63
700242464	3/8"	X	24"	20"	3/8"	\$17.71
700243264	1/2"	X	24"	20"	3/8"	\$20.42
700244064	5/8"	X	24"	20"	Hex 1/2"	\$22.96
700246464	1"	X	24"	20"	Hex 1/2"	\$53.75



- Heavy Duty
- ANSI Standard
- Made In Europe.
- Unique Percussion Grade of Tungsten Carbide Especially Designed for Rotary Hammer Drill Bits.
- Unique Spiral Flute for Fast Removal of Dust. No Blow Back or Compacting.
- Unique Ground Flute.
- Unique Heat Treatment Process for Best Impact Resistance.
- Unique Hex Shank Design on Larger Diameters to Prevent Slipping in the Chuck.
- Unique Grinding of Carbide Tip for Fast Penetration.
- Polished Flute.
- Suitable For:
 - Concrete
 - Stones
 - Marble
 - Granite

HEAVY DUTY

NOTE:
These Drill Bits are made for machines with percussion. They will not perform with rotation only.

PACKAGED IN INDIVIDUAL POUCHES



MAIN OFFICE

INTERNATIONAL TOOL MANUFACTURING
71-08 51ST. AVENUE, WOODSIDE, NY 11377
(718) 446-0711 • (800) 247-5696 • FAX (718) 899-6553



INTERNATIONAL TOOL MANUFACTURING
675-E-PROGRESS CENTER AVE., LAWRENCEVILLE, GA 30043
(770) 962-5454 • (800) 229-1776 • FAX (770) 962-5869

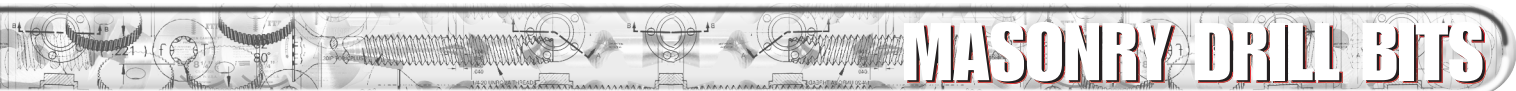

DURO ◆ TEX

Carbide Tipped Multi Purpose Drill Bits - Gold Finish

DURO ◆ TEX MULTI PURPOSE BITS

BRICK - CERAMIC - TILE - MARBLE - FIBERGLASS - METAL - WOOD

PART NUMBER	DRILL SIZE	O/A LENGTH	DRILLING DEPTH	SHANK SIZE	PRICE EACH
600CD0864	1/8"	3"	1-1/2"	1/8"	\$3.23
600CD1064	5/32"	3-1/8"	1-3/4"	5/32"	\$3.42
600CD1264	3/16"	3-1/2"	2-3/16"	3/16"	\$5.08
600CD1664	1/4"	4-1/8"	2-9/16"	1/4"	\$6.47
600CD1864	9/32"	4-3/8"	2-3/4"	9/32"	\$7.10
600CD2064	5/16"	4-3/4"	3-5/32"	5/16"	\$8.18
600CD2464	3/8"	6"	4-3/8"	3/8"	\$11.32
600CD3264	1/2"	6-3/4"	4"	1/2"	\$13.27
600CD4064	5/8"	6"	4"	1/2"	\$16.16

"THE PERFECT CARBIDE BIT FOR ANY FASTENING OR RENOVATION JOB!!!"

The DURO u TEX drill bit is specially developed for efficient rotary drilling in a wide range of different materials in one operation without the need of changing the drill bit.

The special Plus-Point grinding of the carbide tip and the newly developed Turbo I flute give DURO u TEX users the advantages of extremely low drilling pressures, a self centering tip, high wearability, a strong cutting edge, and fast, easy removal of spoil. Ideal for cordless machines and any fastening jobs where drilling in different materials is necessary.

DURO u TEX works strictly with rotation, which is more protective to the environment, the operator, the machine,

PACKAGED IN INDIVIDUAL POUCHES WITH INSTRUCTIONS

GLASS CARBIDE BITS

SERIES 601GL BRIGHT FINISH

PART NUMBER	DRILL SIZE	O/A LENGTH	SHANK	PRICE EACH
601GL0864	1/8"	2-1/4"	1/8"	\$7.41
601GL1264	3/16"	2-3/4"	3/16"	\$8.54
601GL1664	1/4"	3"	1/4"	\$9.05
601GL2064	5/16"	3-1/4"	1/4"	\$10.05
601GL2464	3/8"	3-1/2"	3/8"	\$14.13
601GL3264	1/2"	4"	3/8"	\$20.10



- Tungsten Carbide Spear Point.
- Suitable For:
 - All Grade of Glass & Mirrors.
 - Very Hard Ceramic Tiles.

ROTATION ONLY - NO PERCUSSION

Slow drilling speeds and lubricant are recommended when using these drills.

ACCESSORIES



SAFETY GOGGLES

PART #	DESCRIPTION	PRICE
GOG0001	Individual Goggles	\$3.06



DUST MASKS

PART #	DESCRIPTION	PRICE
MAS0001	MASKS - 50 / Box	\$13.25

MAIN OFFICE

INTERNATIONAL TOOL MANUFACTURING
71-08 51ST. AVENUE, WOODSIDE, NY 11377
(718) 446-0711 • (800) 247-5696 • FAX (718) 899-6553



INTERNATIONAL TOOL MANUFACTURING
675-E-PROGRESS CENTER AVE., LAWRENCEVILLE, GA 30043
(770) 962-5454 • (800) 229-1776 • FAX (770) 962-5869

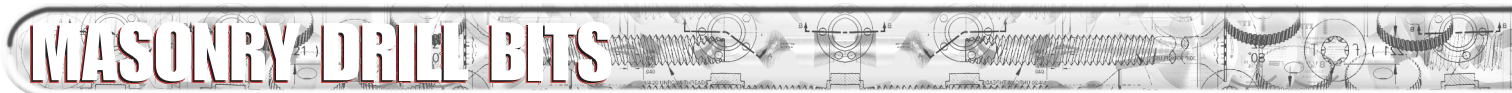

SDS - PLUS

COMPATIBLE MACHINES FOR ALL ITM SDS-PLUS HAMMER BITS LISTED ON PAGES 66-69.

AEG®	
APH14	PHE24
PH210	PHE26
PHE16	PN2200R
PHE19	PN3000
PHE20	PN3500

B & D®	
5009	5013K
5014K	5016
5053K	5054K
5056K	5057K

BOSCH®	
11207	11210
11211	11212
11213RK	11215
11221DVS	
11222EVS/G	
11224VSR	
11225VSR/H	
11228VSR	11234VSR
11236VS	11239VS
11524	

DEWALT®	
DW514K	DW523K
DW557K	DW562K
DW563K	DW565K
DW566K	DW567K
DW570K	

HITACHI®	
DH22VB	DH22VD
DH24PB	DH24PE
DH24PC	VR16
VRT22	

HILTI®	
TE 1	TE 2 (M)
TE 5 (A)	TE 6-A
TE 10A	TE 12 (S)
TE 14	TE 15ME
TE 17	TE 18
TE 22P	GP 22
TE 24	TE 25 (S)

MAKITA®	
HR160	HR1821
HR2000	HR2010
HR2400	HR2410
HR2420	HR2431
HR2511	HR3000C
8015DW	

KANGO®	
200	285
327	422
426	430D

MILWAUKEE®	
5302	5303
5312	5317
5320	5324
5359	5360
5362	5365
5366	5368
5369	5383

METABO®	
6010	6011
6015	6018
6020	6021
6024	6026
6028	BHE22
BHE24	KHE24
KHE28	KHE32

RED HEAD®	
555	715

PORTER CABLE	
639	

RAMSET®	
425	

RYOBI®	
ED160	ED211

FEIN®	
6372	642

SPLINE

COMPATIBLE MACHINES FOR ALL ITM SPLINE HAMMER BITS LISTED ON PAGES 64-65.

AEG®	
PH38	PHD26
PHD38	PH240D

B & D®	
5041	5042
5043	5044K
5045K	5059
5093K	5095K
5096K	5098K

BOSCH®	
11202	11203
11204	11205
11209	11214
11219	11220
11232EVS	11233EVS
11244E	11247
11248EVS	11314

DEWALT®	
530K	531K
532K	533K
D25650K	D25550K
D25551K	

HITACHI®	
DH38YE (G)	DH40FA
DH40FB	DS50SB (K)

KANGO®	
430S	501S
637S	750S
950S	978S

MAKITA®	
HR3851	HR4040C
HR5000	

METABO®	
RH66	RH99X
1129	1130
6030	6040
6046	

MILWAUKEE®	
5309	5311
5316	5318-21
5319-21	5321-22
5341	5343
5344	5345-21
5347	5348
5352	

RAMSET®	
442	445
475	

RED HEAD®	
747-2	

RYOBI®	
ED382P	ER382

WACKER®	
EBH 10	

SDS - MAX®

COMPATIBLE MACHINES FOR ALL ITM SDS-MAX® HAMMER BITS LISTED ON PAGE 63.

AEG®	
PN4000E	

BOSCH®	
11214EVS	11216
11223	11227E
11230EVS	11231
11235EVS	11240
11241EVS	11245EVS

B & D®	
5097K	5099K

DEWALT®	
541K	545K
D25500K	D25600K

HILTI®	
TE-F-52	TE-F-60
TE-F-72	TE-F-92
TE-Y-54	TE-Y-55
TE-Y-74	TE-Y-75
TE-Y-76	

HITACHI®	
DH40MA	DH40MB
DH50MB	

MAKITA®	
HR4000C	HR4500C
HR5001C	

MILWAUKEE®	
5308	5313
5314-21	5315-21
5315-22	5346-21

METABO®	
6045	

What is the difference between Rotary Hammer bits and Rotary Percussion Bits?

The machine numbers listed here are for Rotary Hammer Machines only.

Rotary Hammer bits have special shanks designed to fit in large rotary hammer machines. These machines turn at about 180-500 rpm (rotations per minute), and hit an average of 2500-3500 bpm (blows per minute). Of course, this depends on the machine in use, and the speed setting. Rotary hammer machines also hit much harder than rotary percussion machines.

Rotary Percussion bits are generally smaller and will always have either a straight shank, or a hex shank. These fit in Jacob style chuck rotary percussion machines, and turn much faster; about 1300-3500 rpm, and up to 48,000 bpm. Like rotary hammer machines, the impacting action of the rotary percussion machine on the drill bit actually fractures the concrete into tiny granules which can then be removed by the drill bit's spiral flute. Rotary percussion machines are favored for light duty applications.

Rotary-only bits (i.e. no percussion) do not break the concrete, but grind at it under operator pressure.

MAIN OFFICE

INTERNATIONAL TOOL MANUFACTURING
71-08 51ST. AVENUE, WOODSIDE, NY 11377
(718) 446-0711 • (800) 247-5696 • FAX (718) 899-6553



INTERNATIONAL TOOL MANUFACTURING
675-E-PROGRESS CENTER AVE., LAWRENCEVILLE, GA 30043
(770) 962-5454 • (800) 229-1776 • FAX (770) 962-5869

CARBIDE HAMMER DRILL BITS

SDS - MAX® X-CUTTER



Bosch® License

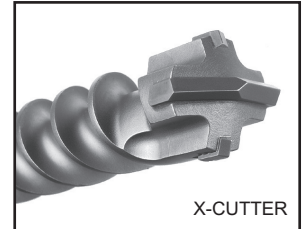

X-CUTTER

SDS-MAX®

- Industrial Quality.
- Special Tungsten Carbide Tip.
- Copper Silver Brazing of Carbide Head.
- Double Spiral.
- Fastest Dust Removal.
- Fastest Drilling Speeds.
- Clean Round Holes.
- Less Vibration.
- ANSI Specification.
- Made In Europe.
- Suitable for:
 - Masonry
 - Stone
 - Brick
 - Aggregates



BARCODED

SOLD INDIVIDUALLY TUBED



See page 62 for a listing of machines compatible with SDS-Max Hammer Drills.



MADE IN GERMANY

SERIES SMTE ROTARY HAMMER DRILL BITS

PART NUMBER	DRILL SIZE	X	O/A LENGTH	DRILLING DEPTH	HEAD STYLE	PRICE EACH
SMTE1338	3/8"	X	13"	8"	REGULAR	\$44.46
SMTE1312	1/2"	X	13"	8"	REGULAR	\$43.00
SMTE1712	1/2"	X	17"	12"	REGULAR	\$53.82
SMTE2212	1/2"	X	21"	15-1/2"	REGULAR	\$56.79
SMTE1391	9/16"	X	13"	8"	REGULAR	\$66.72
SMTE2192	9/16"	X	21"	15-1/2"	REGULAR	\$87.10
SMTE1358	5/8"	X	13"	8"	X-CUTTER	\$51.88
SMTE1758	5/8"	X	17"	12"	X-CUTTER	\$59.03
SMTE2258	5/8"	X	21"	15-1/2"	X-CUTTER	\$62.73
SMTE3658	5/8"	X	36"	31"	X-CUTTER	\$135.72
SMTE2111	11/16"	X	21"	15-1/2"	X-CUTTER	\$90.70
SMTE1334	3/4"	X	13"	8"	X-CUTTER	\$53.79
SMTE1734	3/4"	X	17"	12"	X-CUTTER	\$63.72
SMTE2234	3/4"	X	21"	15-3/4"	X-CUTTER	\$70.14
SMTE3634	3/4"	X	36"	32"	X-CUTTER	\$148.17
SMTE2113	13/16"	X	21"	17"	X-CUTTER	\$96.40
SMTE1378	7/8"	X	13"	9"	X-CUTTER	\$63.33
SMTE1778	7/8"	X	17"	12"	X-CUTTER	\$72.59
SMTE2278	7/8"	X	21"	17"	X-CUTTER	\$76.55
SMTE3678	7/8"	X	36"	32"	X-CUTTER	\$195.69
SMTE1301	1"	X	13"	8"	X-CUTTER	\$69.29
SMTE1701	1"	X	17"	12"	X-CUTTER	\$80.04
SMTE2201	1"	X	21"	17"	X-CUTTER	\$84.13
SMTE3601	1"	X	36"	32"	X-CUTTER	\$207.94
SMTE2311	1-1/16"	X	23"	18"	X-CUTTER	\$113.75
SMTE1718	1-1/8"	X	17"	13"	X-CUTTER	\$91.88
SMTE2218	1-1/8"	X	21"	17"	X-CUTTER	\$108.67
SMTE3618	1-1/8"	X	36"	32"	X-CUTTER	\$235.63
SMTE2313	1-3/16"	X	23"	18"	X-CUTTER	\$140.20
SMTE1714	1-1/4"	X	15"	11"	X-CUTTER	\$119.29
SMTE2214	1-1/4"	X	23"	17"	X-CUTTER	\$127.47
SMTE3614	1-1/4"	X	36"	32"	X-CUTTER	\$249.13
SMTE1738	1-3/8"	X	17"	12"	X-CUTTER	\$133.08
SMTE2238	1-3/8"	X	23"	17"	X-CUTTER	\$140.28
SMTE3638	1-3/8"	X	36"	32"	X-CUTTER	\$281.38
SMTE1721	1-1/2"	X	17"	13"	X-CUTTER	\$164.50
SMTE2221	1-1/2"	X	22"	17"	X-CUTTER	\$208.72
SMTE2334	1-3/4"	X	23"	18"	X-CUTTER	\$295.30
SMTE2202	2"	X	23"	18"	X-CUTTER	\$327.44



MAIN OFFICE

INTERNATIONAL TOOL MANUFACTURING
71-08 51ST. AVENUE, WOODSIDE, NY 11377
(718) 446-0711 • (800) 247-5696 • FAX (718) 899-6553



INTERNATIONAL TOOL MANUFACTURING
675-E-PROGRESS CENTER AVE., LAWRENCEVILLE, GA 30043
(770) 962-5454 • (800) 229-1776 • FAX (770) 962-5869

CARBIDE HAMMER DRILL BITS



SPLINE DRIVE

SERIES 717SP ROTARY HAMMER DRILL BITS

PART NUMBER	DRILL SIZE	X	O/A LENGTH	DRILLING DEPTH	HEAD STYLE	PRICE EACH
717SP0838	3/8"	X	8"	3"	REGULAR	\$33.81
717SP1238	3/8"	X	11"	6"	REGULAR	\$37.80
717SP1638	3/8"	X	16"	11"	REGULAR	\$49.19
717SP1371	7/16"	X	13"	8"	REGULAR	\$47.15
717SP1212	1/2"	X	11"	6"	REGULAR	\$39.84
717SP1612	1/2"	X	16"	11"	REGULAR	\$46.47
717SP2212	1/2"	X	23"	18"	REGULAR	\$60.39
717SP2812	1/2"	X	27"	22"	REGULAR	\$73.08
717SP3612	1/2"	X	36"	31"	REGULAR	\$92.19
717SP1291	9/16"	X	11"	6"	REGULAR	\$39.90
717SP1691	9/16"	X	16"	11"	REGULAR	\$47.69
717SP2291	9/16"	X	23"	18"	REGULAR	\$56.48
717SP2891	9/16"	X	27"	22"	REGULAR	\$70.70
717SP1258	5/8"	X	11"	6"	REGULAR	\$45.44
717SP1658	5/8"	X	16"	11"	REGULAR	\$47.08
717SP2258	5/8"	X	23"	18"	REGULAR	\$67.28
717SP2858	5/8"	X	27"	22"	REGULAR	\$88.96
717SP3658	5/8"	X	36"	31"	REGULAR	\$143.47
717SP1211	11/16"	X	13"	8"	REGULAR	\$52.28
717SP1611	11/16"	X	16"	11"	REGULAR	\$65.32
717SP1234	3/4"	X	11"	6"	REGULAR	\$47.85
717SP1634	3/4"	X	16"	11"	REGULAR	\$51.01
717SP2234	3/4"	X	23"	18"	REGULAR	\$68.58
717SP2834	3/4"	X	27"	22"	REGULAR	\$83.44
717SP3634	3/4"	X	36"	31"	REGULAR	\$151.39
717SP1627	27/32"	X	16"	11"	REGULAR	\$72.45
717SP1678	7/8"	X	16"	11"	REGULAR	\$64.82
717SP2278	7/8"	X	23"	18"	REGULAR	\$77.69
717SP3678	7/8"	X	36"	31"	REGULAR	\$159.56
717SP1201	1"	X	13"	8"	REGULAR	\$75.59
717SP1601	1"	X	16"	11"	REGULAR	\$77.70
717SP2201	1"	X	23"	18"	REGULAR	\$83.43
717SP3601	1"	X	36"	31"	REGULAR	\$169.17
717SP1618	1-1/8"	X	16"	11"	REGULAR	\$79.40
717SP2218	1-1/8"	X	23"	18"	REGULAR	\$92.95
717SP1614	1-1/4"	X	16"	11"	REGULAR	\$91.31
717SP2214	1-1/4"	X	23"	18"	REGULAR	\$103.24
717SP3614	1-1/4"	X	36"	31"	REGULAR	\$189.34
717SP1613	1-3/8"	X	16"	11"	REGULAR	\$112.61
717SP2213	1-3/8"	X	23"	18"	REGULAR	\$120.67
717SP6112	1-1/2"	X	16"	11"	REGULAR	\$112.00
717SP4112	1-1/2"	X	23"	18"	REGULAR	\$136.66
717SP3234	1-3/4"	X	23"	18"	REGULAR	\$214.12
717SP2202	2"	X	23"	18"	REGULAR	\$244.04

- Industrial Quality.
- Special Tungsten Carbide Tip.
- Copper Silver Brazing of Carbide Head.
- Fastest Dust Removal.
- Fastest Drilling Speeds.
- Clean Round Holes.
- Less Vibration.
- ANSI Specification.
- Made In Europe.
- Suitable for:
 - Masonry
 - Stone
 - Brick
 - Aggregates



01234 567890

BARCODED

SOLD INDIVIDUALLY TUBED



See page 62 for a listing of machines compatible with SPLINE Hammer Drills.



MADE IN GERMANY

MAIN OFFICE

INTERNATIONAL TOOL MANUFACTURING
71-08 51ST. AVENUE, WOODSIDE, NY 11377
(718) 446-0711 • (800) 247-5696 • FAX (718) 899-6553



INTERNATIONAL TOOL MANUFACTURING
675-E-PROGRESS CENTER AVE., LAWRENCEVILLE, GA 30043
(770) 962-5454 • (800) 229-1776 • FAX (770) 962-5869

CARBIDE HAMMER DRILL BITS

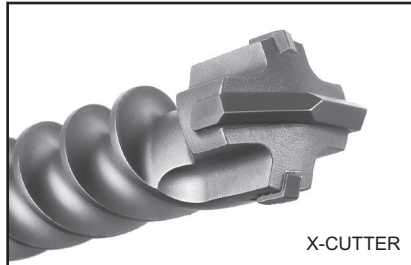

X-CUTTER

SPLINE DRIVE X-CUTTER

SERIES 7SPCR ROTARY HAMMER DRILL

PART NUMBER	DRILL SIZE	X	O/A LENGTH	DRILLING DEPTH	HEAD STYLE	PRICE EACH
7SPCR1058	5/8"	X	10"	5"	X-CUTTER	\$55.04
7SPCR1658	5/8"	X	16"	11"	X-CUTTER	\$63.95
7SPCR2258	5/8"	X	22"	17"	X-CUTTER	\$76.16
7SPCR2958	5/8"	X	29"	24"	X-CUTTER	\$105.62
7SPCR3658	5/8"	X	36"	31"	X-CUTTER	\$147.34
7SPCR1034	3/4"	X	10"	5"	X-CUTTER	\$63.64
7SPCR1634	3/4"	X	16"	11"	X-CUTTER	\$68.09
7SPCR2234	3/4"	X	22"	17"	X-CUTTER	\$80.62
7SPCR2934	3/4"	X	29"	24"	X-CUTTER	\$110.65
7SPCR3634	3/4"	X	36"	31"	X-CUTTER	\$152.89
7SPCR1678	7/8"	X	16"	11"	X-CUTTER	\$72.32
7SPCR2278	7/8"	X	22"	17"	X-CUTTER	\$89.08
7SPCR1601	1"	X	16"	11"	X-CUTTER	\$76.16
7SPCR2201	1"	X	22"	17"	X-CUTTER	\$95.88
7SPCR2901	1"	X	29"	24"	X-CUTTER	\$136.75
7SPCR3601	1"	X	36"	31"	X-CUTTER	\$186.24
7SPCR1618	1-1/8"	X	16"	11"	X-CUTTER	\$95.61
7SPCR2218	1-1/8"	X	22"	17"	X-CUTTER	\$125.38
7SPCR1614	1-1/4"	X	16"	11"	X-CUTTER	\$105.62
7SPCR2214	1-1/4"	X	22"	17"	X-CUTTER	\$133.40
7SPCR2914	1-1/4"	X	29"	24"	X-CUTTER	\$186.10
7SPCR3614	1-1/4"	X	36"	31"	X-CUTTER	\$201.98
7SPCR1638	1-3/8"	X	16"	11"	X-CUTTER	\$133.40
7SPCR2238	1-3/8"	X	22"	17"	X-CUTTER	\$149.80
7SPCR2212	1-1/2"	X	22"	17"	X-CUTTER	\$172.35



- Industrial Quality.
- 4-Cutters.
- Special Tungsten Carbide Tips.
- Copper Silver Brazing of Carbide Head.
- Special Steel for High Torque Resistance.
- Unique Hardening Process for Extended Drill Life.
- Double Spiral.
- KVS - Flute with Core Reinforcement.
- ANSI Specification.
- Suitable for:
 - Concrete
 - Masonry
 - Stone
 - Brick
 - Aggregates



BARCODED

SOLD INDIVIDUALLY TUBED



See page 62 for a listing of machines compatible with SPLINE Hammer Drills.



MADE IN GERMANY

MAIN OFFICE

INTERNATIONAL TOOL MANUFACTURING
71-08 51ST. AVENUE, WOODSIDE, NY 11377
(718) 446-0711 • (800) 247-5696 • FAX (718) 899-6553



INTERNATIONAL TOOL MANUFACTURING
675-E-PROGRESS CENTER AVE., LAWRENCEVILLE, GA 30043
(770) 962-5454 • (800) 229-1776 • FAX (770) 962-5869

CARBIDE HAMMER DRILL BITS



- Special Tungsten Carbide Tip.
- Copper Silver Brazing of Carbide Head.
- Special Flute Design Improves Penetration without Blow Back or Compacting.
- ANSI Specification.
- Made in Europe.
- Suitable for:
 - Masonry
 - Stone
 - Brick
 - Aggregates



BARCODED



Call For BULK PACKS



SDS-PLUS

PART NUMBER	DRILL SIZE	X	O/A LENGTH	DRILLING DEPTH	HEAD STYLE	PRICE EACH
715S41064	5/32"	X	4-1/2"	2"	4-PLUS	\$5.97
715S61064	5/32"	X	6-1/4"	4"	4-PLUS	\$6.81
715S41264	3/16"	X	4-1/2"	2"	4-PLUS	\$5.97
715S61264	3/16"	X	6-1/4"	4"	4-PLUS	\$6.81
715S81264	3/16"	X	8-1/4"	6"	4-PLUS	\$9.42
715S10316	3/16"	X	10"	8"	4-PLUS	\$12.50
715S12316	3/16"	X	12"	10"	4-PLUS	\$15.50
715S14316	3/16"	X	14"	12"	4-PLUS	\$22.59
715S16316	3/16"	X	16"	14"	4-PLUS	\$29.66
715S41464	7/32"	X	4-1/2"	2"	4-PLUS	\$6.99
715S61464	7/32"	X	6-1/4"	4"	4-PLUS	\$7.22
715S81464	7/32"	X	8-1/4"	6"	4-PLUS	\$8.97
715S11732	7/32"	X	11"	9"	4-PLUS	\$16.21
715S16732	7/32"	X	16"	14"	4-PLUS	\$26.21
715S41664	1/4"	X	4-1/2"	2"	4-PLUS	\$5.97
715S61664	1/4"	X	6-1/4"	4"	4-PLUS	\$6.81
715S91664	1/4"	X	8-1/4"	6"	4-PLUS	\$8.97
715S11014	1/4"	X	11"	9"	4-PLUS	\$11.45
715S12014	1/4"	X	12"	10"	4-PLUS	\$14.90
715S14014	1/4"	X	14"	12"	4-PLUS	\$22.45
715S16014	1/4"	X	16"	14"	4-PLUS	\$24.22
715S20014	1/4"	X	20"	18"	4-PLUS	\$29.04
715S62064	5/16"	X	6-1/4"	4"	4-PLUS	\$8.31
715S92064	5/16"	X	8-1/4"	6"	4-PLUS	\$11.02
715S12516	5/16"	X	12"	10"	4-PLUS	\$20.75
715S62464	3/8"	X	6-1/4"	4"	4-PLUS	\$9.03
715S92464	3/8"	X	8-1/4"	6"	4-PLUS	\$10.42
715S10038	3/8"	X	10-1/4"	8"	4-PLUS	\$14.61
715S12038	3/8"	X	12-1/4"	10"	4-PLUS	\$18.53
715S18038	3/8"	X	18"	16"	4-PLUS	\$26.72
715S24038	3/8"	X	24"	22"	4-PLUS	\$34.39
715S62864	7/16"	X	6-1/4"	4"	4-PLUS	\$12.44
715S92864	7/16"	X	9"	7"	4-PLUS	\$16.02
715S10716	7/16"	X	10-1/4"	8"	4-PLUS	\$17.56
715S12716	7/16"	X	12-1/4"	10"	4-PLUS	\$19.56
715S18716	7/16"	X	18"	16"	4-PLUS	\$29.33
715S63264	1/2"	X	6-1/4"	4"	4-PLUS	\$10.39
715S10012	1/2"	X	10-1/4"	8"	4-PLUS	\$17.93
715S12012	1/2"	X	12-1/4"	10"	4-PLUS	\$19.56
715S12018	1/2"	X	18"	16"	4-PLUS	\$24.02
715S12024	1/2"	X	24"	22"	4-PLUS	\$44.10

7 PC. SDS-PLUS SET

RED METAL INDEX

PART # 715SM0007	\$59.05
3/16" X 4-1/2"	1/4" X 6-1/2"
1/4" X 4-1/2"	5/16" X 6-1/2"
5/16" X 4-1/2"	3/8" X 6-1/2"
	1/2" X 6-1/2"

i SDS-Plus Hammer Drill Bits Sold Individually in Hangable Vinyl Pouches. Bulk Pack SDS Bits Packaged in Tubes. See Page 62 for SDS Rotary Hammer Guide.

MAIN OFFICE

INTERNATIONAL TOOL MANUFACTURING
71-08 51ST. AVENUE, WOODSIDE, NY 11377
(718) 446-0711 • (800) 247-5696 • FAX (718) 899-6553



INTERNATIONAL TOOL MANUFACTURING
675-E-PROGRESS CENTER AVE., LAWRENCEVILLE, GA 30043
(770) 962-5454 • (800) 229-1776 • FAX (770) 962-5869

CARBIDE HAMMER DRILL BITS

SDS-PLUS

PART NUMBER	DRILL SIZE	X	O/A LENGTH	DRILLING DEPTH	HEAD STYLE	PRICE EACH
715S63664	9/16"	X	6-1/4"	4"	4-PLUS	\$16.10
715S10916	9/16"	X	10-1/4"	8"	4-PLUS	\$20.79
715S12916	9/16"	X	12-1/4"	10"	4-PLUS	\$24.15
715S18916	9/16"	X	18"	16"	4-PLUS	\$27.60
715S64064	5/8"	X	6-1/4"	4"	4-PLUS	\$12.83
715S94064	5/8"	X	8"	6"	4-PLUS	\$18.43
715S12058	5/8"	X	12"	10"	4-PLUS	\$26.72
715S18058	5/8"	X	18"	16"	4-PLUS	\$38.19
715S24058	5/8"	X	24"	22"	4-PLUS	\$47.21
715S14464	11/16"	X	10"	8"	REGULAR	\$31.75
715S94864	3/4"	X	8"	6"	REGULAR	\$23.72
715S10034	3/4"	X	10"	8"	REGULAR	\$29.26
715S12034	3/4"	X	12"	10"	REGULAR	\$34.61
715S18034	3/4"	X	18"	16"	REGULAR	\$46.35
715S24034	3/4"	X	24"	22"	REGULAR	\$60.67
715S95664	7/8"	X	8"	6"	REGULAR	\$41.59
715S10078	7/8"	X	10"	8"	REGULAR	\$44.48
715S12078	7/8"	X	12"	10"	REGULAR	\$46.93
715S18078	7/8"	X	18"	14"	REGULAR	\$52.01
715S96464	1"	X	8"	6"	REGULAR	\$46.24
715S10001	1"	X	10"	8"	REGULAR	\$51.88
715S12001	1"	X	12"	10"	REGULAR	\$54.72
715S18001	1"	X	18"	16"	REGULAR	\$73.33



3 Head Styles:



4-PLUS

A new, fast, & tough carbide tip provides long life, easy centering, and fast drilling through all aggregates, concrete, masonry, brick, stone, and even rebar!



REGULAR

Traditional Tungsten Carbide Tip with Copper Silver Brazing for clean drilling through all aggregates, concrete, masonry, brick, & stone. Regular heads are found on SDS-PLUS sizes over 5/8".



SDS-PLUS X-CUTTER

PART NUMBER	DRILL SIZE	X	O/A LENGTH	DRILLING DEPTH	HEAD STYLE	PRICE EACH
750TE020	5/8"	X	10"	8"	X-CUTTER	\$24.40
750TE030	5/8"	X	12"	10"	X-CUTTER	\$31.56
750TE040	5/8"	X	18"	16"	X-CUTTER	\$40.22
750TE100	3/4"	X	10"	8"	X-CUTTER	\$42.00
750TE110	3/4"	X	12"	10"	X-CUTTER	\$47.33
750TE120	3/4"	X	18"	16"	X-CUTTER	\$54.89
750TE130	27/32"	X	10"	8"	X-CUTTER	\$54.22
750TE140	7/8"	X	8"	6"	X-CUTTER	\$51.60
750TE150	7/8"	X	10"	8"	X-CUTTER	\$54.76
750TE160	7/8"	X	12"	10"	X-CUTTER	\$62.00
750TE170	7/8"	X	18"	16"	X-CUTTER	\$65.56
750TE180	1"	X	8"	6"	X-CUTTER	\$54.89
750TE190	1"	X	10"	8"	X-CUTTER	\$60.44
750TE200	1"	X	12"	10"	X-CUTTER	\$72.22
750TE210	1"	X	18"	16"	X-CUTTER	\$82.09
750TE220	1-1/8"	X	10"	8"	X-CUTTER	\$89.60
750TE240	1-1/4"	X	18"	16"	X-CUTTER	\$99.11



X-CUTTER

4 Sided Traditional Tungsten Carbide Tip with Copper Silver Brazing for *Super Fast* clean drilling through all aggregates, concrete, masonry, brick, & stone. Will not cut rebar!



See page 62 for a listing of machines compatible with SDS-PLUS Hammer Drills.

MADE IN GERMANY

MAIN OFFICE

INTERNATIONAL TOOL MANUFACTURING
71-08 51ST. AVENUE, WOODSIDE, NY 11377
(718) 446-0711 • (800) 247-5696 • FAX (718) 899-6553



INTERNATIONAL TOOL MANUFACTURING
675-E-PROGRESS CENTER AVE., LAWRENCEVILLE, GA 30043
(770) 962-5454 • (800) 229-1776 • FAX (770) 962-5869

CARBIDE HAMMER DRILL BITS

Concrete Screw System



Half Flat Shank

CONCRETE BITS FOR CONCRETE SCREWS

SERIES 602TC BULK

PART NUMBER	DRILL SIZE	O/A LENGTH	FOR SCREW	PACKED	PRICE EACH
602TC0503	5/32"	3-1/2"	12	BULK	\$3.17
602TC0500	5/32"	4-1/2"	12	BULK	\$3.31
602TC0505	5/32"	5-1/2"	12	BULK	\$3.60
602TC0603	3/16"	3-1/2"	14	BULK	\$3.60
602TC0604	3/16"	4-1/2"	14	BULK	\$3.73
602TC0605	3/16"	5-1/2"	14	BULK	\$4.01
602TC0606	3/16"	6-3/4"	14	BULK	\$4.72
602TC0607	3/16"	7-5/8"	14	BULK	\$5.67

CONCRETE BITS FOR CONCRETE SCREWS

SERIES 602TC 10 PER TUBE

PART NUMBER	DRILL SIZE	O/A LENGTH	FOR SCREW	PACKED	PRICE EACH
610TT0503	5/32"	3-1/2"	12	10/TUBE	\$31.70
610TT0500	5/32"	4-1/2"	12	10/TUBE	\$33.10
610TT0505	5/32"	5-1/2"	12	10/TUBE	\$36.00
610TT0603	3/16"	3-1/2"	14	10/TUBE	\$36.00
610TT0604	3/16"	4-1/2"	14	10/TUBE	\$37.30
610TT0605	3/16"	5-1/2"	14	10/TUBE	\$40.10
610TT0606	3/16"	6-3/4"	14	10/TUBE	\$47.20
610TT0607	3/16"	7-5/8"	14	10/TUBE	\$56.70

Each concrete screw carbide drill bit is precisely ground to match a certain tolerance to assure proper hole diameter and to achieve maximum thread holding power. The flat on the shank fits all drill adapters. The drill bit is specially heat treated to make it very durable.

Concrete Screw System



5/16" HEX SHOULDER

SDS-HEX BITS FOR CONCRETE SCREWS

SERIES SDS-HEX

PART NUMBER	SIZE	DRILLING DEPTH	PRICE EACH
HEX5325	5/32" x 5" SDS HEX	2-1/2"	\$10.92
HEX5327	5/32" x 7" SDS HEX	4-1/2"	\$12.17
HEX3165	3/16" x 5" SDS HEX	2-1/2"	\$10.92
HEX3167	3/16" x 7" SDS HEX	4-1/2"	\$12.17
HEX2345	.234 X 5" SDS HEX	2-1/2"	\$10.92
HEX2347	.234 X 7" SDS HEX	4-1/2"	\$12.17

SDS-HEX Rotary Hammer drill bits are specifically designed to be used in concrete screw installation. These SDS bits have a special 5/16" **HEX** shoulder for use with standard concrete Installation sleeves, which eliminate the need for drill adapters. The benefits of using an SDS machine rather than a standard rotation drill means a decrease in operation time of nearly 50%.

SEE BELOW FOR INSTALLATION KITS AND SLEEVES.

- ANSI Specification.
- Tungsten Carbide Head.
- Suitable for
 - Masonry
 - Stone
 - Brick

For a Listing of SDS Machines, See Page 68.

Concrete Screw System

- Red Case.
- Black Hardware.

This Installation Kit is Suitable for both Standard Concrete Bits & SDS-HEX Rotary Hammer Bits.



602TC1000

CONCRETE SCREW INSTALLATION KIT & REPLACEMENT PARTS

PART NUMBER	DESCRIPTION	PRICE EACH
602TC1000	INSTALLATION KIT	\$50.00
TPC14	1/4" Magnetic Driver	\$6.53
TPC516	5/16" Magnetic Driver	\$6.53
TPCBA	Phillips Bit Adapter	\$10.13
TPCHP	Masonry Drill Adapter	\$11.26
TPCDSL	6-1/2" Sleeve	\$15.45
HEX18	1/8" Hex Key	\$0.39
T3-025-02	Phillips #2 x 1" Insert	\$0.40
T3-025-03	Phillips #3 x 1" Insert	\$0.40
CSCASE	Plastic Case	\$11.25

MAIN OFFICE

INTERNATIONAL TOOL MANUFACTURING
71-08 51ST. AVENUE, WOODSIDE, NY 11377
(718) 446-0711 • (800) 247-5696 • FAX (718) 899-6553



INTERNATIONAL TOOL MANUFACTURING
675-E-PROGRESS CENTER AVE., LAWRENCEVILLE, GA 30043
(770) 962-5454 • (800) 229-1776 • FAX (770) 962-5869

ADAPTERS

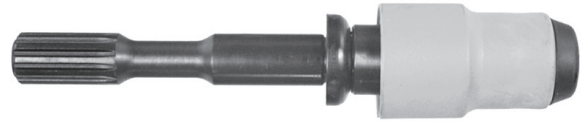
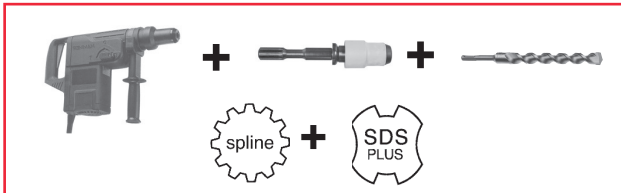

Adapters will take all **SDS-Plus** Hammer Drill Bits listed on pages 66–69.

SPLINE to SDS-PLUS

PART #	DESCRIPTION	PRICE
725SP0001	QUICK CHANGE SPLINE TO SDS-PLUS ADAPTER	\$80.32

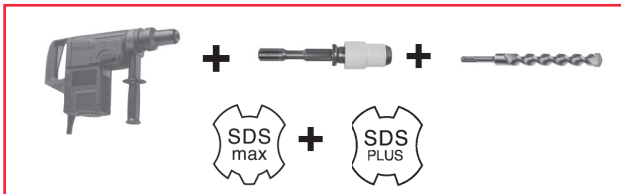

Adapters will take all **SDS-Plus** Hammer Drill Bits listed on pages 66–69.

SDS-MAX to SDS-PLUS

PART #	DESCRIPTION	PRICE
725MAX001	QUICK CHANGE SDS-MAX TO SDS-PLUS ADAPTER	\$80.32

REPLACEMENT KIT

PART #	DESCRIPTION	PRICE
715KIT001	ADAPTER REPLACEMENT PARTS KIT INCLUDES GASKETS AND BALL BEARINGS	\$4.50

MAIN OFFICE

INTERNATIONAL TOOL MANUFACTURING
71-08 51ST. AVENUE, WOODSIDE, NY 11377
(718) 446-0711 • (800) 247-5696 • FAX (718) 899-6553



INTERNATIONAL TOOL MANUFACTURING
675-E-PROGRESS CENTER AVE., LAWRENCEVILLE, GA 30043
(770) 962-5454 • (800) 229-1776 • FAX (770) 962-5869

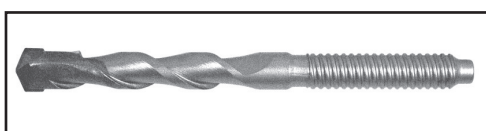
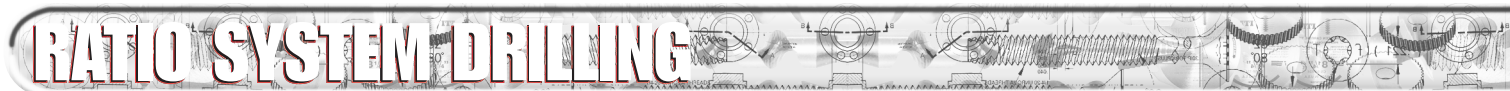

PILOT DRILL BIT

2

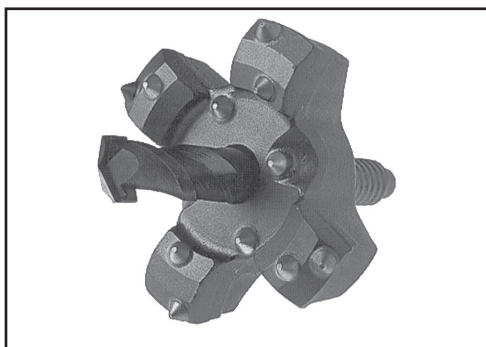

CRUCIFORM™ DRILL HEAD
PILOT DRILL BIT PICTURED IS NOT INCLUDED

3

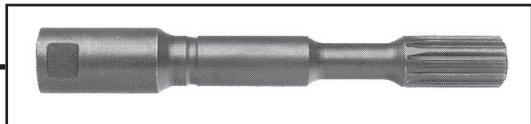

SPLINE ADAPTER

1

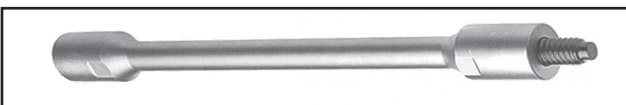

11" EXTENSION

4

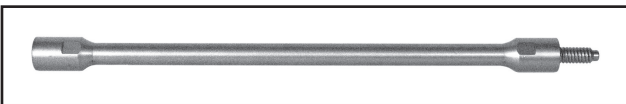

18" EXTENSION

5

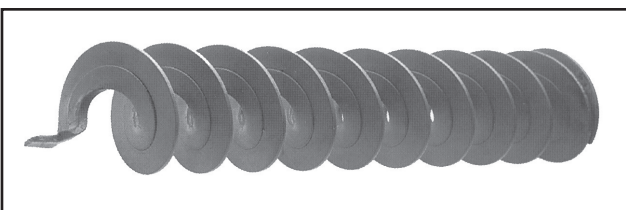

16" SPIRAL FLUTE

6

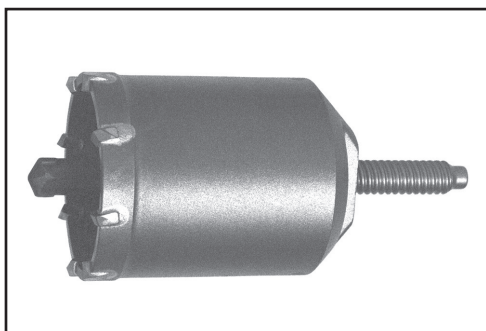

RATIO CORE BIT

7

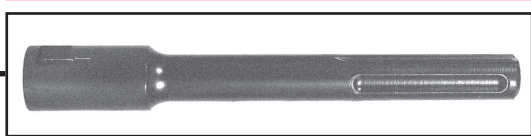

SDS-MAX® ADAPTER

1

INDUSTRIAL SOLUTIONS FOR INDUSTRIAL CONTRACTORS...

Ratio Cruciform™ Drilling System

- Modular System
- Up to 6" Diameter
- Allows for Angle Drilling
- Use With or Without Spiral Flute
- Adapters Accommodate Any Combination
- Unmatched Flexibility

Ratio Cruciform™ bits can be fine tuned to various applications with upmost ease. The easy to assemble / disassemble bit system, combined with unmatched durability and flexibility, make Ratio System Drilling the professional's choice. Interchangeable parts make it the most economical system to date. Easily used in electric Rotary Hammer Machines when drill rigs, diamond cutting, and water are unavailable.

Drill any hole from 1-1/2" to 6" in Diameter. Choose a Cruciform™ Drill Head from **3**, and then drill any depth up to 75" deep*.

Use The Following Combinations:

DEPTH	COMBINATION
4"	1 2 3
14-12"	1 2 3 4
21-1/2"	1 2 3 5
32-1/2"	1 2 3 4 5 6
39-1/2"	1 2 3 5 5 6
50-1/2"	1 2 3 4 5 5 6
61-1/2"	1 2 3 4 4 5 5 6
68-1/2"	1 2 3 4 5 5 5 6
75"	1 2 3 5 5 5 5 6

* Actual Drilling Depth will depend on Rotary Hammer Machine power, diameter of Drill Head, and aggregate drilled upon.



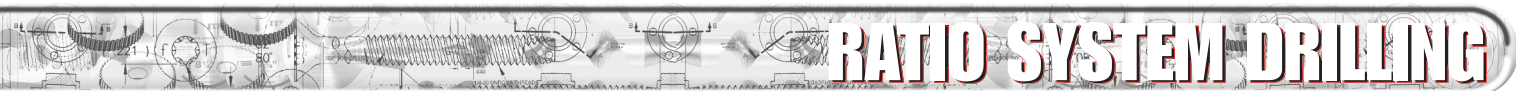

ADAPTERS

PART NUMBER	DESCRIPTION	O/L	PRICE EACH
800RA010	SPLINE ADAPTER	7"	\$74.36
800RA020	SDS-MAX ADAPTER	7"	\$74.36

1

If you are not certain which adapter to use, refer to the Hammer Selection Guide on page 68.

PILOT DRILL

PART NUMBER	DESCRIPTION	PRICE EACH
800RP124	5/8" X 4-3/4" PILOT	\$41.33 - RECOMMENDED.
800RP174	5/8" X 6-3/4" PILOT	\$44.59 - BETTER FOR DEEP DRILLING.
800RP255	1/2" X 6" PILOT	\$33.43 - FOR RATIO CORE BIT ONLY!!!

2

CRUCIFORM™ HEAD

PART NUMBER	DESCRIPTION	O/L	PRICE EACH
800RC040	1-1/2" DRILL HEAD	1-1/2"	\$214.20
800RC045	1-3/4" DRILL HEAD	1-1/2"	\$228.10
800RC052	2" DRILL HEAD	1-1/2"	\$259.89
800RC065	2-5/8" DRILL HEAD	1-1/2"	\$351.64
800RC080	3-1/8" DRILL HEAD	1-1/2"	\$396.64
800RC090	3-1/2" DRILL HEAD	1-1/2"	\$462.93 *
800RC100	4" DRILL HEAD	1-1/2"	\$495.96 *
800RC110	4-1/2" DRILL HEAD	1-1/2"	\$619.79 *
800RC125	5" DRILL HEAD	1-1/2"	\$709.78 *
800RC150	6" DRILL HEAD	1-1/2"	\$1040.39 *

3

* SPIRAL FLUTES cannot be used with these diameters.

EXTENSIONS

PART NUMBER	DESCRIPTION	PRICE EACH
800RE300	11" LONG EXTENSION	\$116.17 - FOR DRILL HEAD & CORE BIT.
800RE450	18" LONG EXTENSION	\$131.92 - FOR DRILL HEAD & CORE BIT.
800RE455	18" LONG EXTENSION	\$131.92 - USE THIS EXTENSION ONLY WHEN USING A SPIRAL FLUTE!!!

4 & 5

SPIRAL FLUTE

PART NUMBER	DESCRIPTION	O/L	PRICE EACH
800RF140	1-1/2" FLUTE	16"	\$84.95
800RF145	1-3/4" FLUTE	16"	\$99.13
800RF152	2" FLUTE	16"	\$120.35
800RF165	2-5/8" FLUTE	16"	\$293.84
800RF180	3-1/8" FLUTE	16"	\$446.06

6

If you are going to use a Spiral Flute, the diameter of the flute must be the same as the diameter of the Cruciform™ Drill Head.

USE EXTENSION #800RE455 ONLY!!!

RATIO CORE BITS

PART NUMBER	DESCRIPTION	O/L	PRICE EACH
800RK150	1-1/2" CORE BIT	3"	\$154.39
800RK200	2" CORE BIT	3"	\$161.40
800RK250	2-1/2" CORE BIT	3"	\$192.98
800RK300	3" CORE BIT	3"	\$224.52
800RK350	3-1/2" CORE BIT	3"	\$257.15
800RK400	4" CORE BIT	3"	\$292.39
800RK500	5" CORE BIT	3"	\$316.94

7

USE PILOT DRILL # 800RP255 ONLY!!!

For deeper holes, use either #800RE300 or #800RE450 as extensions. DO NOT USE EXTENSION # 800RE455.



REPLACEMENT COUPLER
 800RT001 \$22.15

What You Need To Use This System:

- You need to have an ADAPTER which will work in the Rotary Hammer Machine you are using. Only two styles are available, Spline Drive and SDS-MAX. Only these machines have the capacity to deliver the torque required to drill holes up to 6" in diameter. The usable length on these Adapters is only 2" (5" of shank fits into the Rotary Hammer).
- Whether you drill with the Cruciform™ Drill Head or the Ratio Core Bit, a Pilot Drill Bit is necessary. The Pilot Drill Bit fastens the Drill Head or Core Bit onto the Extensions. The Pilot Drill bit also ensures you are drilling in a straight line. Use only the 1/2" x 6" Pilot Drill Bit for the Ratio Core Bit.
- The Cruciform™ Drill Head has Tungsten Carbide knobs which grind away at concrete, much like the carbide slots on single piece hammer drill bits. For deep drilling, choose a Drill Head according to the size hole you require. Cruciform™ Drill Heads are interchangeable with all Adapters and Extensions. Using a Pilot Drill Bit, Cruciform™ Drill Heads can Fasten directly onto an Adapter when drilling under 3-1/2" deep.
- Extensions are necessary only for drilling holes deeper than 3-1/2" for the Cruciform™ Drill Head, or 5" for the Ratio Core Bit. All Extensions are interchangeable with each other, and can accommodate any Adapter, Pilot Drill Bit, Cruciform™ Drill Head or Ratio Core Bit.
- A Spiral Flute is needed mostly when drilling vertically to ensure clearance of debris. For horizontal drilling under 18", a Spiral Flute may not be required at all. If a Spiral Flute will be used, be sure to use 18" Extension # 800RE455 first. Other extension can then be fastened on to #800RE455 if deeper drilling is necessary.
- Core Bits are preferable for short depth drilling. 1 & 2 are all that is required. Extensions can be used if necessary.

Be sure to use a slow reciprocating movement when drilling deep holes to allow for clearance of debris.



All parts sold separately. Drilling through REBAR will cause damage to system.



MAIN OFFICE

INTERNATIONAL TOOL MANUFACTURING
71-08 51ST. AVENUE, WOODSIDE, NY 11377
(718) 446-0711 • (800) 247-5696 • FAX (718) 899-6553



INTERNATIONAL TOOL MANUFACTURING
675-E-PROGRESS CENTER AVE., LAWRENCEVILLE, GA 30043
(770) 962-5454 • (800) 229-1776 • FAX (770) 962-5869

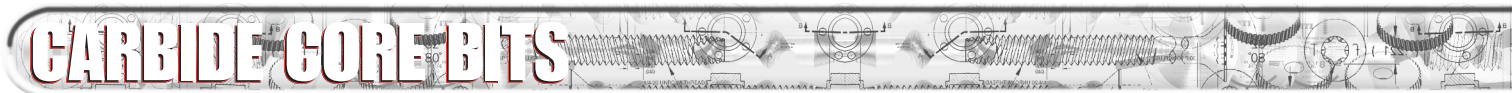

PILOT DRILL

A-TAPER PILOT DRILL FOR EXTENSIONS

PART NUMBER	SIZE	PRICE EACH
721PD0385	3/8" X 5" A-TAPER	\$11.63

EJECTOR KEY

PART NUMBER	SIZE	PRICE EACH
722EJ0001	EJECTOR KEY	\$6.17

CARBIDE CORE BITS

SERIES 719CB 4" TAPERED CORE BITS

PART NUMBER	SIZE	# OF TEETH	PRICE EACH
719CB0040	1-1/2"	6	\$110.02
719CB0050	2"	6	\$122.66
719CB0065	2-1/2"	9	\$141.81
719CB0080	3"	9	\$167.23
719CB0090	3-1/2"	9	\$190.02
719CB0100	4"	9	\$269.64
719CB0125	5"	12	\$377.60

These Heavy Duty Rotary Hammer Core Bits are used with either Spline or SDS-MAX electric rotary hammer machines. The special alloy steel body and Tungsten Carbide withstand continuous hammering. A pilot drill bit and extension are required. See page 62 for a list of compatible machines.

- INSTRUCTIONS**
- 1) Clean the Oil or Lubricant from the Taper of the Extension and the Taper from the Core Bit.
 - 2) Insert the Pilot Bit into the Drive Extension.
 - 3) Insert the Drive Extension into the Core Bit.
 - 4) Start the Hole Until the Core Bit is 3/8" deep.
 - 5) With the Ejector Key, Push Out the Pilot Drill Bit.
 - 6) Continue Drilling the Hole Until the Material Being Drilled Reaches the Bottom of the Core Bit. Approximately 3-1/2" Deep.
 - 7) Break the Drilled Material Inside the Core Bit with a Chisel.
 - 8) Return to Step 6 Until Desired Hole is Finished.

EXTENSIONS

SPLINE DRIVE

PART NUMBER	SIZE	SHANK TYPE	PRICE EACH
720SP0009	9"	SPLINE	\$40.35
720SP0014	14"	SPLINE	\$50.23
720SP0022	22"	SPLINE	\$61.28

SDS - MAX®

PART NUMBER	SIZE	SHANK TYPE	PRICE EACH
720MAX008	8"	SDS-MAX	\$50.77
720MAX018	18"	SDS-MAX	\$63.54



Notice: Core Bit drilling without the use of a pilot drill bit causes excessive pressure on the taper shank system. This *can* result in breakage of the extension at the tapered end, especially between the two slots. Such jagged breaks are not considered defective and *may* not be covered under warrantee.



MAIN OFFICE

INTERNATIONAL TOOL MANUFACTURING
71-08 51ST. AVENUE, WOODSIDE, NY 11377
(718) 446-0711 • (800) 247-5696 • FAX (718) 899-6553



INTERNATIONAL TOOL MANUFACTURING
675-E-PROGRESS CENTER AVE., LAWRENCEVILLE, GA 30043
(770) 962-5454 • (800) 229-1776 • FAX (770) 962-5869

CORE BITS

1-PC SDS-MAX CORE BITS

SERIES 990HH 1-PIECE CONSTRUCTION

PART NUMBER	DRILL SIZE	X	O/A LENGTH	# OF TEETH	SHANK	PRICE EACH
990HH1015	1-1/2"	X	12"	4	SDS-MAX	\$226.60
990HH1025	1-1/2"	X	22"	4	SDS-MAX	\$271.43
990HH1155	1-3/4"	X	12"	6	SDS-MAX	\$239.65
990HH1165	1-3/4"	X	22"	6	SDS-MAX	\$267.85
990HH1035	2"	X	12"	6	SDS-MAX	\$247.99
990HH1045	2"	X	22"	6	SDS-MAX	\$290.93
990HH1055	2-5/8"	X	12"	8	SDS-MAX	\$281.70
990HH1065	2-5/8"	X	22"	8	SDS-MAX	\$320.21
990HH1075	3-1/8"	X	12"	8	SDS-MAX	\$340.35
990HH1085	3-1/8"	X	22"	8	SDS-MAX	\$378.61
990HH1095	3-1/2"	X	12"	10	SDS-MAX	\$358.47
990HH1105	3-1/2"	X	22"	10	SDS-MAX	\$388.68
990HH1115	4"	X	12"	10	SDS-MAX	\$418.89
990HH1125	4"	X	22"	10	SDS-MAX	\$447.08
990HH1215	5"	X	12"	14	SDS-MAX	\$471.25
990HH1135	5"	X	22"	14	SDS-MAX	\$493.40
990HH1145	6"	X	22"	18	SDS-MAX	\$654.51



- Industrial Quality.
- Special Tungsten Carbide Tipped.
- Copper Silver Brazing of Carbide Teeth.
- Clean Round Holes.
- Less Vibration.
- ANSI Specification.
- Made In Germany.
- Suitable for:
 - Masonry
 - Stone
 - Brick
 - Aggregates

Each Core Bit sold with Pilot Drill & Key.

MADE IN GERMANY



BARCODED

SOLD INDIVIDUALLY TUBED



See page 62 for a listing of machines compatible with SDS-Max & Spline Drive Hammer Drills.



1-PC SPLINE CORE BITS

SERIES 920HH 1-PIECE CONSTRUCTION

PART NUMBER	DRILL SIZE	X	O/A LENGTH	# OF TEETH	SHANK	PRICE EACH
920HH1505	1-1/2"	X	12"	4	SPLINE	\$240.02
920HH1515	1-1/2"	X	22"	4	SPLINE	\$281.90
920HH1665	1-3/4"	X	12"	6	SPLINE	\$242.67
920HH1675	1-3/4"	X	22"	6	SPLINE	\$277.92
920HH1525	2"	X	12"	6	SPLINE	\$252.18
920HH1535	2"	X	22"	6	SPLINE	\$294.27
920HH1545	2-5/8"	X	12"	8	SPLINE	\$290.28
920HH1555	2-5/8"	X	22"	8	SPLINE	\$331.77
920HH1565	3-1/8"	X	12"	8	SPLINE	\$353.96
920HH1575	3-1/8"	X	22"	8	SPLINE	\$402.33
920HH1585	3-1/2"	X	12"	10	SPLINE	\$372.81
920HH1595	3-1/2"	X	22"	10	SPLINE	\$413.85
920HH1605	4"	X	12"	10	SPLINE	\$426.94
920HH1615	4"	X	22"	10	SPLINE	\$467.22
920HH1625	5"	X	12"	14	SPLINE	\$487.36
920HH1635	5"	X	22"	14	SPLINE	\$515.56
920HH1655	6"	X	22"	18	SPLINE	\$680.69



PILOT DRILL & KEY

REPLACEMENT PILOT & KEY FOR 1-PC

PART NUMBER	SIZE	PRICE EACH
900PD1143	7/16" X 4-3/4" A-TAPER	\$10.27
900DK7006	EJECTOR KEY	\$9.80

MAIN OFFICE
INTERNATIONAL TOOL MANUFACTURING
71-08 51ST. AVENUE, WOODSIDE, NY 11377
(718) 446-0711 • (800) 247-5696 • FAX (718) 899-6553



INTERNATIONAL TOOL MANUFACTURING
675-E-PROGRESS CENTER AVE., LAWRENCEVILLE, GA 30043
(770) 962-5454 • (800) 229-1776 • FAX (770) 962-5869

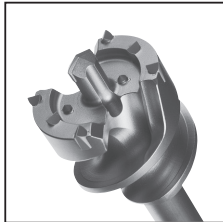
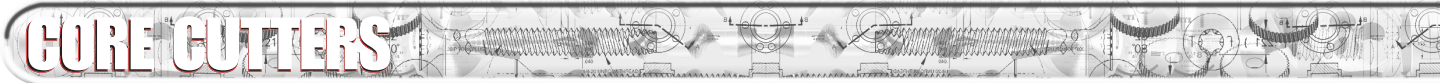

- Industrial Quality.
- Special Tungsten Carbide Tipped.
- Copper Silver Brazing of Carbide Teeth.
- Clean Round Holes.
- Fast Dust Removal.
- Fast Drilling Speeds.
- Less Vibration.
- ANSI Specification.
- Made In Germany.
- Suitable for:
 - Masonry
 - Stone
 - Brick
 - Aggregates



SDS-MAX CORE CUTTER

SERIES 950CC 1-PIECE CONSTRUCTION

PART NUMBER	DRILL SIZE	X	O/A LENGTH	SHANK	PRICE EACH
950CC7330	1-1/2"	X	12-1/4"	SDS-MAX	\$222.94
950CC7331	1-1/2"	X	22"	SDS-MAX	\$268.45
950CC7332	1-3/4"	X	12-1/4"	SDS-MAX	\$237.03
950CC7333	1-3/4"	X	22"	SDS-MAX	\$273.53
950CC7342	1-3/4"	X	39"	SDS-MAX	\$362.50
950CC7336	2-1/8"	X	12-1/4"	SDS-MAX	\$269.58
950CC7337	2-1/8"	X	22"	SDS-MAX	\$308.41
950CC7343	2-1/8"	X	39"	SDS-MAX	\$406.81
950CC7338	2-1/2"	X	12-1/4"	SDS-MAX	\$295.24
950CC7339	2-1/2"	X	22"	SDS-MAX	\$313.28
950CC7344	2-1/2"	X	39"	SDS-MAX	\$439.03
950CC7340	3-1/8"	X	12-1/4"	SDS-MAX	\$337.04
950CC7341	3-1/8"	X	22"	SDS-MAX	\$373.09
950CC7345	3-1/8"	X	39"	SDS-MAX	\$503.47

MADE IN GERMANY



SOLD INDIVIDUALLY TUBED



See page 62 for a listing of machines compatible with SDS-Max & Spline Drive Hammer Drills.



SPLINE CORE CUTTER

SERIES 900CC 1-PIECE CONSTRUCTION

PART NUMBER	DRILL SIZE	X	O/A LENGTH	SHANK	PRICE EACH
900CC7201	1-1/2"	X	12-1/4"	SPLINE	\$234.01
900CC7203	1-1/2"	X	22"	SPLINE	\$281.86
900CC7220	1-3/4"	X	12-1/4"	SPLINE	\$248.92
900CC7208	1-3/4"	X	22"	SPLINE	\$303.86
900CC7221	2-1/8"	X	12-1/4"	SPLINE	\$290.00
900CC7217	2-1/8"	X	22"	SPLINE	\$343.81
900CC7207	2-1/2"	X	12-1/4"	SPLINE	\$312.11
900CC7209	2-1/2"	X	22"	SPLINE	\$363.27
900CC7210	3-1/8"	X	12-1/4"	SPLINE	\$398.79
900CC7212	3-1/8"	X	22"	SPLINE	\$450.47



MAIN OFFICE
INTERNATIONAL TOOL MANUFACTURING
71-08 51ST. AVENUE, WOODSIDE, NY 11377
(718) 446-0711 • (800) 247-5696 • FAX (718) 899-6553



INTERNATIONAL TOOL MANUFACTURING
675-E-PROGRESS CENTER AVE., LAWRENCEVILLE, GA 30043
(770) 962-5454 • (800) 229-1776 • FAX (770) 962-5869

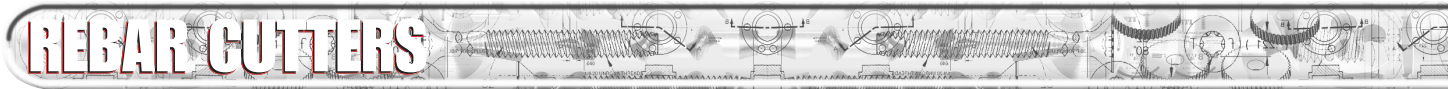

**MADE
 IN THE
 USA**

CARBIDE REBAR CUTTERS

SERIES RBC

1/2" STRAIGHT SHANK

PART NUMBER	SIZE	O/A LENGTH	SUGGESTED RPM's	PRICE EACH
RBC0838	3/8"	8"	850-1200	\$43.13
RBC1212	1/2"	12"	850-1200	\$45.52
RBC1916	9/16"	12"	850-1200	\$47.93
RBC1258	5/8"	12"	750-1000	\$59.90
RBC1858	5/8"	18"	750-1000	\$79.07
RBC1116	11/16"	12"	750-1000	\$64.70
RBC1234	3/4"	12"	600-850	\$67.09
RBC1834	3/4"	18"	600-850	\$88.65
RBC1316	13/16"	12"	600-850	\$81.46
RBC1278 *	7/8"	12"	600-850	\$95.84
RBC1201 *	1"	12"	500-750	\$103.03
RBC1218 *	1-1/8"	12"	500-750	\$110.22
RBC1214 *	1-1/4"	12"	450-600	\$117.41
RBC1238 *	1-3/8"	12"	450-600	\$129.39
RBC1112 *	1-1/2"	12"	350-500	\$136.58
RBC1134 *	1-3/4"	12"	350-500	\$158.14
RBC1202 *	2"	12"	350-500	\$268.36
RBC1222 *	2-1/2"	12"	350-500	\$316.28

* Sizes 7/8" to 2-1/2" have threaded, screw-on (replaceable) heads. Exchange heads with any of the below extensions.

PART NUMBER	SIZE	PRICE EACH
RBCS-1212	12" REBAR SHANK (1/2" - 13)	\$17.52
RBCS-1234	12" REBAR SHANK (3/4" - 10)	\$17.52
RBCS-1812	18" REBAR SHANK (1/2" - 13)	\$24.45
RBCS-1834	18" REBAR SHANK (3/4" - 10)	\$24.45
RBCS-2412	24" REBAR SHANK (1/2" - 13)	\$32.58
RBCS-2434	24" REBAR SHANK (3/4" - 10)	\$32.58
RSDS-1212	12" SDS-PLUS SHANK (1/2" - 13)	\$21.60
RSDS-1234	12" SDS-PLUS SHANK (3/4" - 10)	\$21.60
RSDS-1812	18" SDS-PLUS SHANK (1/2" - 13)	\$30.25
RSDS-1834	18" SDS-PLUS SHANK (3/4" - 10)	\$30.25
RSDS-2412	24" SDS-PLUS SHANK (1/2" - 13)	\$40.35
RSDS-2434	24" SDS-PLUS SHANK (3/4" - 10)	\$40.35

What to do when you encounter rebar:

- 1) **STOP DRILLING!!!** The sound of a rotary hammer or a carbide hammer drill bit hitting steel is much higher than when cutting concrete.
- 2) Remove the drill bit from the hole.
- 3) Mount a rebar cutter of the same diameter as the hole in either a standard 1/2" drill motor, or a 1/2" rotary percussion drill with the selector in the "rotary only" position.
- 4) Insert the rebar cutter into the hole and begin drilling at the suggested RPM speed only. Apply just enough pressure to grind away at the rebar. **Do Not Use Excessive Speed or Pressure on the Machine** - this will either damage or break the rebar cutter.
- 5) Once rebar is cut through, remove the rebar cutter from the hole and continue drilling with a rotary hammer or carbide hammer drill bit.

- Carbide cutters are brazed in place to keep Rebar Cutter from enlarging existing hole.

SIZES

7/8" → 1-3/4"
 2" → 2-1/2"

THREAD

1/2"-13
 3/4"-10



REMINDER:

Rebar Cutters are problem solvers only. A 1/2" Rebar Cutter drilling through #6 (3/4") rebar dead center may result in 5 to 10 holes being drilled provided correct speed and pressure are utilized. It is not uncommon for only one piece of rebar to be cut per Rebar Cutter. Rebar Cutters *should not* be used for drilling concrete.

Rebar Cutters are not warranted for replacement or repair.

MAIN OFFICE
INTERNATIONAL TOOL MANUFACTURING
 71-08 51ST. AVENUE, WOODSIDE, NY 11377
 (718) 446-0711 • (800) 247-5696 • FAX (718) 899-6553



INTERNATIONAL TOOL MANUFACTURING
 675-E-PROGRESS CENTER AVE., LAWRENCEVILLE, GA 30043
 (770) 962-5454 • (800) 229-1776 • FAX (770) 962-5869

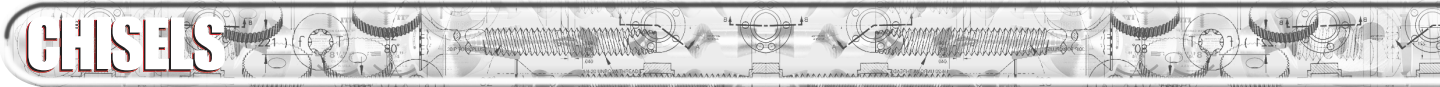









See page 62 for a listing of machines compatible with Spline Drive Chisels.

SPLINE DRIVE CHISELS











NOTE: Spline Drive chisels have rounded hex shanks to work effectively in Spline Drive machines made with and without rotation / hammer only switches.

	PART NUMBER	SIZE	STYLE	PRICE EACH
	714BP0012	12"	BULLPOINT	\$18.03
	714BP0018	18"	BULLPOINT	\$22.56
	714FC0012	1" X 12"	FLAT CHISEL	\$18.03
	714FC0018	1" X 18"	FLAT CHISEL	\$22.86
	714SC0012	2" X 12"	SCALING CHISEL	\$28.26
	714SC0018	2" X 18"	SCALING CHISEL	\$34.05
	714ST0012	1-1/2" X 12"	SLOTING TOOL	\$29.20
	714BPBH01	10"	BUSHING HEAD DR.	\$69.50
	714BPSP12	10"	BUSHING DRIVER	\$34.56
	714BH1212	1-3/4" X 1-3/4"	BUSHING HEAD	\$36.04
	714GR0034	3/4" X 10"	GROUND ROD DR.	\$74.03

See page 62 for a listing of machines compatible with SDS-Max Chisels.

SDS-MAX® DRIVE CHISELS



	PART NUMBER	SIZE	STYLE	PRICE EACH
	04001	12"	BULLPOINT	\$24.40
	04002	18"	BULLPOINT	\$27.10
	04004	1" X 12"	FLAT CHISEL	\$24.40
	04005	1" X 18"	FLAT CHISEL	\$27.10
	04009	2" X 18"	SCALING CHISEL	\$45.50
	40010	1-1/2" X 12"	SLOTING TOOL	\$31.11
	714SMBH01	10"	BUSHING HEAD DR.	\$69.50
	714SMBD12	10"	BUSHING DRIVER	\$39.50
	714BH1212	1-3/4" X 1-3/4"	BUSHING HEAD	\$36.04
	40014	3/4" X 10"	GROUND ROD DR.	\$78.75



MAIN OFFICE
INTERNATIONAL TOOL MANUFACTURING
71-08 51ST. AVENUE, WOODSIDE, NY 11377
(718) 446-0711 • (800) 247-5696 • FAX (718) 899-6553



INTERNATIONAL TOOL MANUFACTURING
675-E-PROGRESS CENTER AVE., LAWRENCEVILLE, GA 30043
(770) 962-5454 • (800) 229-1776 • FAX (770) 962-5869

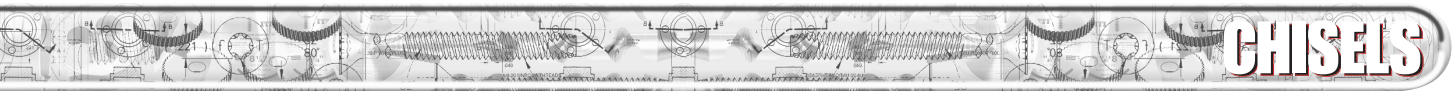

SDS-PLUS DRIVE CHISELS

See page 62 for a listing of machines compatible with SDS-PLUS Chisels.

PART NUMBER	SIZE	STYLE	PRICE EACH
2101	10"	BULLPOINT	\$24.40
2102	3/4" X 10"	FLAT CHISEL	\$24.40
2103	1-1/2" X 10"	FLAT CHISEL	\$27.10



3/4" HEX DEMOLITION CHISELS

- Black & Decker®** 5021K
- Bosch®** 11301 - 11302 - 11305
- Milwaukee®** 5335
- Dewalt®** 5021k, DW558
- Hitachi®** H55SC
- Makita®** HM1211B

PART NUMBER	SIZE	STYLE	PRICE EACH
714DHBP12	12"	BULLPOINT	\$15.61
714DHBP18	18"	BULLPOINT	\$22.86
714DHFC12	1" X 12"	FLAT CHISEL	\$18.37
714DHFC18	1" X 18"	FLAT CHISEL	\$22.86
714DHBD12	10"	BUSHING DRIVER	\$39.50
714BH1212	1-3/4" X 1-3/4"	BUSHING HEAD	\$36.04

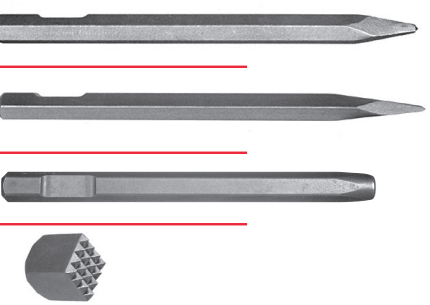

1-1/8" HEX SHANK CHISELS

- Black & Decker®** 5027
- Bosch®** BRUTE 11304
- Milwaukee®** 5338
- Kango®** 2500
- Hitachi®** H65 - H85 - H905SB
- Makita®** HM1303B, HM1500B, HM1800
- Wacker®** EH27

PART NUMBER	SIZE	STYLE	PRICE EACH
2002C/C	20"	BULLPOINT	\$39.40
2004C/C	1-1/2" - 20"	FLAT CHISEL	\$39.40
2006C/C	3" X 20"	SCALING CHISEL	\$67.80
2010C/C	4" X 17"	ASPHALT CUTTER	\$96.24

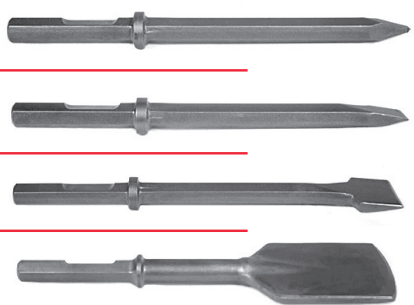

i 1-1/8" HEX Shank Chisels come with Internal locks for Demolition Hammers and External Collars for Pneumatic Hammers.



MAIN OFFICE
INTERNATIONAL TOOL MANUFACTURING
71-08 51ST. AVENUE, WOODSIDE, NY 11377
(718) 446-0711 • (800) 247-5696 • FAX (718) 899-6553



INTERNATIONAL TOOL MANUFACTURING
675-E-PROGRESS CENTER AVE., LAWRENCEVILLE, GA 30043
(770) 962-5454 • (800) 229-1776 • FAX (770) 962-5869

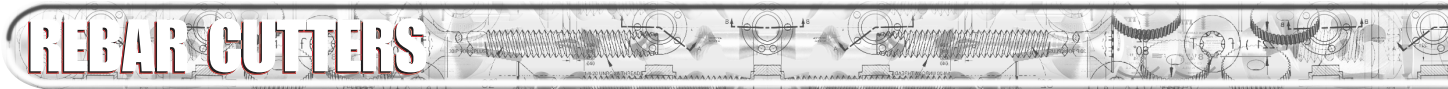

**MADE
 IN THE
 USA**

CARBIDE REBAR CUTTERS

SERIES RBC

1/2" STRAIGHT SHANK

PART NUMBER	SIZE	O/A LENGTH	SUGGESTED RPM's	PRICE EACH
RBC0838	3/8"	8"	850-1200	\$43.13
RBC1212	1/2"	12"	850-1200	\$45.52
RBC1916	9/16"	12"	850-1200	\$47.93
RBC1258	5/8"	12"	750-1000	\$59.90
RBC1858	5/8"	18"	750-1000	\$79.07
RBC1116	11/16"	12"	750-1000	\$64.70
RBC1234	3/4"	12"	600-850	\$67.09
RBC1834	3/4"	18"	600-850	\$88.65
RBC1316	13/16"	12"	600-850	\$81.46
RBC1278 *	7/8"	12"	600-850	\$95.84
RBC1201 *	1"	12"	500-750	\$103.03
RBC1218 *	1-1/8"	12"	500-750	\$110.22
RBC1214 *	1-1/4"	12"	450-600	\$117.41
RBC1238 *	1-3/8"	12"	450-600	\$129.39
RBC1112 *	1-1/2"	12"	350-500	\$136.58
RBC1134 *	1-3/4"	12"	350-500	\$158.14
RBC1202 *	2"	12"	350-500	\$268.36
RBC1222 *	2-1/2"	12"	350-500	\$316.28

* Sizes 7/8" to 2-1/2" have threaded, screw-on (replaceable) heads. Exchange heads with any of the below extensions.

PART NUMBER	SIZE	PRICE EACH
RBCS-1212	12" REBAR SHANK (1/2" - 13)	\$17.52
RBCS-1234	12" REBAR SHANK (3/4" - 10)	\$17.52
RBCS-1812	18" REBAR SHANK (1/2" - 13)	\$24.45
RBCS-1834	18" REBAR SHANK (3/4" - 10)	\$24.45
RBCS-2412	24" REBAR SHANK (1/2" - 13)	\$32.58
RBCS-2434	24" REBAR SHANK (3/4" - 10)	\$32.58
RSDS-1212	12" SDS-PLUS SHANK (1/2" - 13)	\$21.60
RSDS-1234	12" SDS-PLUS SHANK (3/4" - 10)	\$21.60
RSDS-1812	18" SDS-PLUS SHANK (1/2" - 13)	\$30.25
RSDS-1834	18" SDS-PLUS SHANK (3/4" - 10)	\$30.25
RSDS-2412	24" SDS-PLUS SHANK (1/2" - 13)	\$40.35
RSDS-2434	24" SDS-PLUS SHANK (3/4" - 10)	\$40.35

What to do when you encounter rebar:

- 1) **STOP DRILLING!!!** The sound of a rotary hammer or a carbide hammer drill bit hitting steel is much higher than when cutting concrete.
- 2) Remove the drill bit from the hole.
- 3) Mount a rebar cutter of the same diameter as the hole in either a standard 1/2" drill motor, or a 1/2" rotary percussion drill with the selector in the "rotary only" position.
- 4) Insert the rebar cutter into the hole and begin drilling at the suggested RPM speed only. Apply just enough pressure to grind away at the rebar. **Do Not Use Excessive Speed or Pressure on the Machine** - this will either damage or break the rebar cutter.
- 5) Once rebar is cut through, remove the rebar cutter from the hole and continue drilling with a rotary hammer or carbide hammer drill bit.

- Carbide cutters are brazed in place to keep Rebar Cutter from enlarging existing hole.

SIZES

7/8" → 1-3/4"
 2" → 2-1/2"

THREAD

1/2"-13
 3/4"-10



REMINDER:

Rebar Cutters are problem solvers only. A 1/2" Rebar Cutter drilling through #6 (3/4") rebar dead center may result in 5 to 10 holes being drilled provided correct speed and pressure are utilized. It is not uncommon for only one piece of rebar to be cut per Rebar Cutter. Rebar Cutters *should not* be used for drilling concrete.

Rebar Cutters are not warranted for replacement or repair.

MAIN OFFICE
INTERNATIONAL TOOL MANUFACTURING
71-08 51ST. AVENUE, WOODSIDE, NY 11377
(718) 446-0711 • (800) 247-5696 • FAX (718) 899-6553



INTERNATIONAL TOOL MANUFACTURING
675-E-PROGRESS CENTER AVE., LAWRENCEVILLE, GA 30043
(770) 962-5454 • (800) 229-1776 • FAX (770) 962-5869

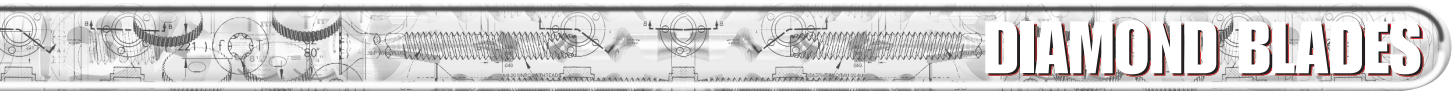

- Industrial Quality
- For Dry & Wet Use
- Individually Blister Carded



ITM Diamond Cutting Wheels are great for general contractor work. Each wheel comes with interchangeable adapters for use in virtually all hand-held saws and angle grinders.

4" TUCK POINT DIAMOND CUTTING WHEEL		
<p>4" Part # TPS40 Price Each \$66.64</p>	<ul style="list-style-type: none"> • DRY TYPE • DIAMETER: 4" ± 0.70MM / 4-1/2" ± 0.70MM • TEETH THICKNESS: 0.25" (-0.00/+0.20MM) • 28 CRMO Body / LASER WELDED BLADE • 20MM ROUND ARBOR W/ 5/8" BUSHING ADAPTER (SOLID BRASS) • 20-25% CONCENTRATION OF DIAMOND GRAIN • 13,700 RPM MAXIMUM 	
4-1/2" TUCK POINT DIAMOND CUTTING WHEEL		
<p>4-1/2" Part # TPS45 Price Each \$77.75</p>	<ul style="list-style-type: none"> • DRY TYPE • DIAMETER: 4-1/2" ± 0.70MM • TEETH THICKNESS: 0.25" (-0.00/+0.20MM) • 28 CRMO Body / LASER WELDED BLADE • 20MM ROUND ARBOR W/ 5/8" BUSHING ADAPTER (SOLID BRASS) • 20-25% CONCENTRATION OF DIAMOND GRAIN • 13,700 RPM MAXIMUM 	

MAIN OFFICE
INTERNATIONAL TOOL MANUFACTURING
71-08 51ST. AVENUE, WOODSIDE, NY 11377
(718) 446-0711 • (800) 247-5696 • FAX (718) 899-6553



INTERNATIONAL TOOL MANUFACTURING
675-E-PROGRESS CENTER AVE., LAWRENCEVILLE, GA 30043
(770) 962-5454 • (800) 229-1776 • FAX (770) 962-5869

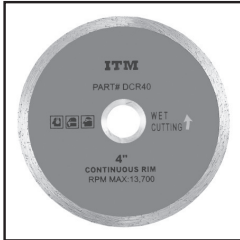
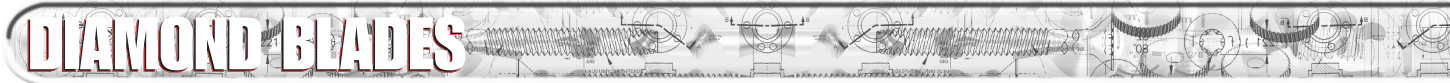

4" CONTINUOUS RIM DIAMOND CUTTING WHEEL	
<p>Part # DCR40</p> <p>Price Each \$14.58</p>	<ul style="list-style-type: none"> • DRY & WET TYPE • DIAMETER: 4" ± 0.70MM • TEETH THICKNESS: 0.08" (-0.00/+0.20MM) • 65MN BODY • 7/8" ROUND ARBOR W/ 20MM & 5/8" BUSHING ADAPTER (SOLID BRASS) • 20-25% CONCENTRATION OF DIAMOND GRAIN • 13,700 RPM MAXIMUM

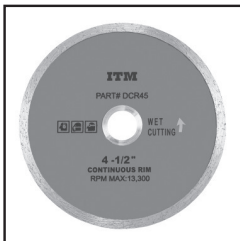

4-1/2" CONTINUOUS RIM DIAMOND CUTTING WHEEL	
<p>Part # DCR45</p> <p>Price Each \$17.36</p>	<ul style="list-style-type: none"> • DRY & WET TYPE • DIAMETER: 4-1/2" ± 0.70MM • TEETH THICKNESS: 0.08" (-0.00/+0.20MM) • 65MN BODY • 7/8" ROUND ARBOR W/ 20MM & 5/8" BUSHING ADAPTER (SOLID BRASS) • 20-25% CONCENTRATION OF DIAMOND GRAIN • 13,300 RPM MAXIMUM



7" CONTINUOUS RIM DIAMOND CUTTING WHEEL	
<p>Part # DCR70</p> <p>Price Each \$39.58</p>	<ul style="list-style-type: none"> • DRY & WET TYPE • DIAMETER: 7" ± 0.70MM • TEETH THICKNESS: 0.08" (-0.00/+0.20MM) • 65MN BODY • 7/8" ROUND ARBOR W/ 20MM & 5/8" BUSHING ADAPTER (SOLID BRASS) • 20-25% CONCENTRATION OF DIAMOND GRAIN • 8,400 RPM MAXIMUM

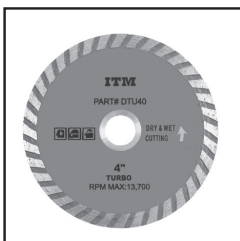

4" TURBO DIAMOND CUTTING WHEEL	
<p>Part # DTU40</p> <p>Price Each \$16.06</p>	<ul style="list-style-type: none"> • DRY & WET TYPE • DIAMETER: 4" ± 0.70MM • TEETH THICKNESS: 0.08" (-0.00/+0.20MM) • 65MN BODY • 7/8" ROUND ARBOR W/ 20MM & 5/8" BUSHING ADAPTER (SOLID BRASS) • 20-25% CONCENTRATION OF DIAMOND GRAIN • 13,700 RPM MAXIMUM

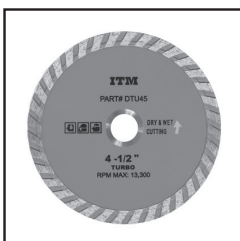

4-1/2" TURBO DIAMOND CUTTING WHEEL	
<p>Part # DTU45</p> <p>Price Each \$20.18</p>	<ul style="list-style-type: none"> • DRY & WET TYPE • DIAMETER: 4-1/2" ± 0.70MM • TEETH THICKNESS: 0.08" (-0.00/+0.20MM) • 65MN BODY • 7/8" ROUND ARBOR W/ 20MM & 5/8" BUSHING ADAPTER (SOLID BRASS) • 20-25% CONCENTRATION OF DIAMOND GRAIN • 13,300 RPM MAXIMUM

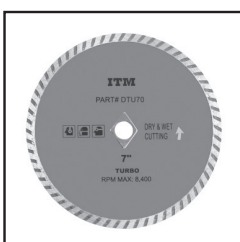

7" TURBO DIAMOND CUTTING WHEEL	
<p>Part # DTU70</p> <p>Price Each \$46.76</p>	<ul style="list-style-type: none"> • DRY & WET TYPE • DIAMETER: 7" ± 0.70MM • TEETH THICKNESS: 0.08" (-0.00/+0.20MM) • 65MN BODY • 7/8" ROUND ARBOR W/ 20MM & 5/8" BUSHING ADAPTER (SOLID BRASS) • 20-25% CONCENTRATION OF DIAMOND GRAIN • 8,400 RPM MAXIMUM

MAIN OFFICE
 INTERNATIONAL TOOL MANUFACTURING
 71-08 51ST. AVENUE, WOODSIDE, NY 11377
 (718) 446-0711 • (800) 247-5696 • FAX (718) 899-6553



INTERNATIONAL TOOL MANUFACTURING
 675-E-PROGRESS CENTER AVE., LAWRENCEVILLE, GA 30043
 (770) 962-5454 • (800) 229-1776 • FAX (770) 962-5869

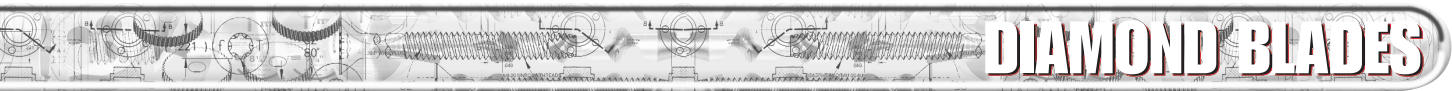

4" SEGMENTED DIAMOND CUTTING WHEEL	
<p>Part # DCS40</p> <p>Price Each \$14.58</p>	<ul style="list-style-type: none"> • DRY TYPE • DIAMETER: 4" ± 0.70MM • TEETH THICKNESS: 0.08" (-0.00/+0.20MM) • 65MN BODY • 7/8" ROUND ARBOR W/ 20MM & 5/8" BUSHING ADAPTER (SOLID BRASS) • 20-25% CONCENTRATION OF DIAMOND GRAIN • 13,700 RPM MAXIMUM

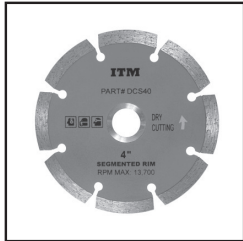

4-1/2" SEGMENTED DIAMOND CUTTING WHEEL	
<p>Part # DCS45</p> <p>Price Each \$17.36</p>	<ul style="list-style-type: none"> • DRY TYPE • DIAMETER: 4-1/2" ± 0.70MM • TEETH THICKNESS: 0.08" (-0.00/+0.20MM) • 65MN BODY • 7/8" ROUND ARBOR W/ 20MM & 5/8" BUSHING ADAPTER (SOLID BRASS) • 20-25% CONCENTRATION OF DIAMOND GRAIN • 13,300 RPM MAXIMUM

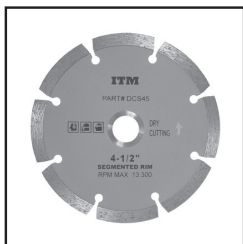

7" SEGMENTED DIAMOND CUTTING WHEEL	
<p>Part # DCS70</p> <p>Price Each \$39.58</p>	<ul style="list-style-type: none"> • DRY TYPE • DIAMETER: 7" ± 0.70MM • TEETH THICKNESS: 0.08" (-0.00/+0.20MM) • 65MN BODY • 7/8" ROUND ARBOR W/ 20MM & 5/8" BUSHING ADAPTER (SOLID BRASS) • 20-25% CONCENTRATION OF DIAMOND GRAIN • 8,400 RPM MAXIMUM

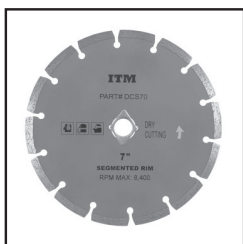

12" SEGMENTED DIAMOND CUTTING WHEEL	
<p>Part # DCS120</p> <p>Price Each \$76.40</p>	<ul style="list-style-type: none"> • DRY TYPE • DIAMETER: 12" • 65MN BODY • TEETH THICKNESS: 0.1"(-0.05/+0.20mm) • TEETH (HIGH): 0.256" (-0.20/+0.70mm) • 1" ROUND ARBOR W/ 20MM & 7/8" BUSHING ADAPTER (SOLID BRASS) • 20-25% CONCENTRATION OF DIAMOND GRAIN • 5,000 RPM MAXIMUM

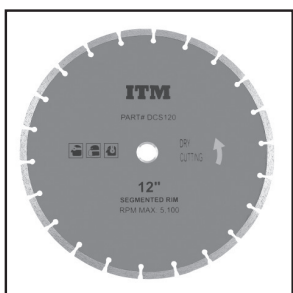

14" SEGMENTED DIAMOND CUTTING WHEEL	
<p>Part # DCS140</p> <p>Price Each \$103.32</p>	<ul style="list-style-type: none"> • DRY TYPE • DIAMETER: 14" • 65MN BODY • TEETH THICKNESS: 0.12"(-0.05/+0.20mm) • TEETH (HIGH): 0.315" (-0.20/+0.70mm) • 1" ROUND ARBOR W/ 20MM & 7/8" BUSHING ADAPTER (SOLID BRASS) • 20-25% CONCENTRATION OF DIAMOND GRAIN • 4,300 RPM MAXIMUM

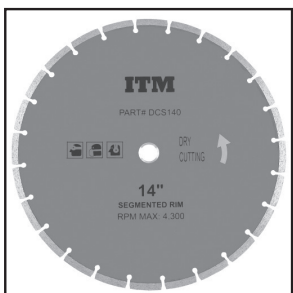

MAIN OFFICE
INTERNATIONAL TOOL MANUFACTURING
 71-08 51ST. AVENUE, WOODSIDE, NY 11377
 (718) 446-0711 • (800) 247-5696 • FAX (718) 899-6553



INTERNATIONAL TOOL MANUFACTURING
 675-E-PROGRESS CENTER AVE., LAWRENCEVILLE, GA 30043
 (770) 962-5454 • (800) 229-1776 • FAX (770) 962-5869

SCREWDRIVER BIT SIZING GUIDES

TECH3

A Unique Combination of Alloys - Nickel - Vanadium - Molybdenum.

The fusion of these alloys gives **ITM TECH3** Screw Driver Tips a Rockwell hardness of Rc. 59-62 *without* the brittleness. TECH3 screw driver tips are the ultimate for the professional who demands and deserves only the best.

Manufactured in a HiTech grey finish.

Exclusively from



PHILLIPS™



SQUARE



SLOTTED



HEX



STAR



STAR TAMPER



HEX TAMPER



POZIDRIV™



TRI-WING™



SPANNER



Not Sure Which Tip Fits Your Screws? Determine exactly which type of screw you have and then find it on the following guides. The column on the far left indicates the correct tip you need. STAR sizes vary according to screw head; see the chart on page 85.

PHILLIPS

ITM Phillips® Screw Driver Tips are found on page 86.

PHILLIPS POINT #	SHEET METAL SCREWS		WOOD SCREWS		MACHINE SCREWS		
	FLAT, ROUND, OVAL	STOVE BINDING	FLAT, OVAL	ROUND	FLAT, OVAL BINDING	ROUND, FILLISTER	TRUSS, BRAZIER BUTTON
0	0, 1		0, 1	0, 1	0, 1	0, 1	0, 1
1	2, 3, 4		2, 3, 4	2, 3, 4	2, 3, 4	2, 3, 4	2, 3, 4, 5
2	5, 6, 7, 8, 10		5, 6, 7, 8, 9	5, 6, 7, 8, 9, 10	5, 6, 8, 10	5, 6, 8, 10	6, 8, 10
3	12, 14		10, 12, 14, 16	12, 14, 16	12, 1/4"	12, 1/4", 5/16"	12, 1/4"

SLOTTED

ITM Slotted Screw Driver Tips are found on page 90.

SLOTTED POINT #	SCREW SIZE	SLOT SCREW WIDTH		THREAD DIA.	THIS SECTION FOR SLOTTED BIT FINDERS ON PAGE 90 ONLY. MAXIMUM HEAD DIAMETER					
		MIN.	MAX.		FLAT or OVAL HEAD	ROUND HEAD	FILLISTER HEAD	BINDING HEAD	PAN HEAD	TRUSS HEAD
4-5	3	.027	.035	.099	.199	.187	.161	.208	.193	.226
4-5	4	.031	.039	.112	.225	.211	.183	.235	.219	.257
6-8	5	.035	.043	.125	.252	.236	.205	.263	.245	.289
8-10	6	.039	.048	.138	.279	.260	.226	.290	.270	.321
10-12	8	.045	.054	.164	.332	.309	.270	.344	.322	.384

PHILLIPS®, POZIDRIV®, & TRI-WING® are Registered Trade Marks of PHILLIPS SCREW Co.



SCREWDRIVER BIT SIZING GUIDES

HEX SOCKET

ITM Hex Socket Screw Driver Tips are found on page 89.

HEX SIZE	SHANK SIZE	CAP SCREW SIZE	SET SCREW SIZE
5/64"	1/4"	2, 3	8
3/32"	1/4"	4, 5	10
7/64"	1/4"	6	•
1/8"	1/4"	•	1/4"
5/32"	1/4"	10	5/16"
3/16"	5/16"	1/4"	3/8"
7/32"	5/16"	•	7/16"
1/4"	5/16"	5/16"	1/2"

SQUARE RECESS

ITM Square Recess Screw Driver Tips are found on page 87.

SQUARE POINT #	TAPPING SCREWS	WOOD SCREWS	MACHINE SCREWS
0	3, 4	3, 4	3, 4
1	5, 6, 7	5, 6, 7	5, 6
2	8, 10	8, 9, 10	8, 10
3	12, 14	12, 14	12, 14

STAR FOR TORX® SCREWS.

ITM Star Screw Driver Tips are found on page 88 & 89.

SCREW SIZE	THREAD DIA.	INTERNAL TORX WASHER HEAD	PAN HEAD	FLAT HEAD	HEX HEAD	TRUSS HEAD	FILLISTER HEAD	OVAL HEAD	SOCKET HEAD CAP	SOCKET SET SCREW
2	.086	T7	T7	T6						
3	.099	T8	T8	T7						
4	.112	T9	T9	T8	T9		T9		T10	T6
5	.125	T10	T10	T9	T10		T10	T10	T10	T7
6	.138	T15	T15	T10	T15	T10	T15	T15	T15	T7
8	.164	T20	T20	T15	T20	T15	T20	T20	T25	T8
10	.190	T25	T25	T20	T25	T20	T25	T25	T27	T10
12	.216	T27	T27	T25	T27	T25	T27	T27	T27	T10
1/4"	.250	T30	T30	T27	T30	T27	T30	T30	T30	T20
5/16"	.312			T40	T40	T40	T40	T40	T45	T27
3/8"	.375			T45	T45	T45	T45	T45	T50	T30
7/16"	.437			T50	T50	T45	T50	T50	T55	T40
1/2"	.500			T55	T50	T50	T55	T50	T55	T45

TORX® is a Registered Trade Mark of Camcar Div. of Textron.

MAIN OFFICE
 INTERNATIONAL TOOL MANUFACTURING
 71-08 51ST. AVENUE, WOODSIDE, NY 11377
 (718) 446-0711 • (800) 247-5696 • FAX (718) 899-6553



INTERNATIONAL TOOL MANUFACTURING
 675-E-PROGRESS CENTER AVE., LAWRENCEVILLE, GA 30043
 (770) 962-5454 • (800) 229-1776 • FAX (770) 962-5869

INDUSTRIAL SCREWDRIVER BITS



PHILLIPS® INSERT BITS

1/4" HEX SHANK



PART NUMBER	POINT SIZE	x	LENGTH	DESCRIPTION	PRICE EACH
T3-025-00	#0	x	1"	PHILLIPS INSERT	\$0.72
T3-025-01	#1	x	1"	PHILLIPS INSERT	\$0.47
T3-025-02	#2	x	1"	PHILLIPS INSERT	\$0.39
T3-025-03	#3	x	1"	PHILLIPS INSERT	\$0.42



PHILLIPS® REDUCED BODY INSERT BITS FOR DRYWALL

1/4" HEX SHANK



PART NUMBER	POINT SIZE	x	LENGTH	DESCRIPTION	PRICE EACH
T3-025-1W	#1	x	1"	PHILLIPS FOR DRYWALL	\$0.42
T3-025-2W	#2	x	1"	PHILLIPS FOR DRYWALL	\$0.42



PHILLIPS® POWER BITS

1/4" HEX SHANK



PART NUMBER	POINT SIZE	x	LENGTH	DESCRIPTION	PRICE EACH
T3-050-01	#1	x	2"	PHILLIPS POWER	\$0.75
T3-070-01	#1	x	2-3/4"	PHILLIPS POWER	\$1.11
T3-075-01	#1	x	3"	PHILLIPS POWER	\$1.06
T3-090-01	#1	x	3-1/2"	PHILLIPS POWER	\$1.22
T3-100-01	#1	x	4"	PHILLIPS POWER	\$1.33
T3-125-01	#1	x	5"	PHILLIPS POWER	\$2.33
T3-150-01	#1	x	6"	PHILLIPS POWER	\$3.08

SPECIAL ITEM

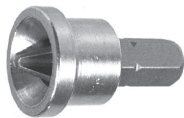

PATENT # 5101698

SP-025-2P
THE STOPPER™
 #2 X 1" Phillips with Collar
 List Price \$1.42 / each

T3-050-02	#2	x	2"	PHILLIPS POWER	\$0.75
T3-070-02	#2	x	2-3/4"	PHILLIPS POWER	\$1.11
T3-075-02	#2	x	3"	PHILLIPS POWER	\$1.06
T3-090-02	#2	x	3-1/2"	PHILLIPS POWER	\$1.22
T3-100-02	#2	x	4"	PHILLIPS POWER	\$1.33
T3-125-02	#2	x	5"	PHILLIPS POWER	\$2.33
T3-150-02	#2	x	6"	PHILLIPS POWER	\$3.08

SPECIAL ITEM



TR-060-03
 Threaded #3 x 1-3/4" Phillips
 Thread = 1/4" - 28
 List Price \$1.69 / each

T3-050-03	#3	x	2"	PHILLIPS POWER	\$0.75
T3-070-03	#3	x	2-3/4"	PHILLIPS POWER	\$1.11
T3-075-03	#3	x	3"	PHILLIPS POWER	\$1.06
T3-090-03	#3	x	3-1/2"	PHILLIPS POWER	\$1.22
T3-100-03	#3	x	4"	PHILLIPS POWER	\$1.33
T3-125-03	#3	x	5"	PHILLIPS POWER	\$2.33
T3-150-03	#3	x	6"	PHILLIPS POWER	\$3.08

MAIN OFFICE
INTERNATIONAL TOOL MANUFACTURING
71-08 51ST. AVENUE, WOODSIDE, NY 11377
(718) 446-0711 • (800) 247-5696 • FAX (718) 899-6553



INTERNATIONAL TOOL MANUFACTURING
675-E-PROGRESS CENTER AVE., LAWRENCEVILLE, GA 30043
(770) 962-5454 • (800) 229-1776 • FAX (770) 962-5869

INDUSTRIAL SCREW DRIVER BITS

PART NUMBER	POINT SIZE	x	LENGTH	DESCRIPTION	PRICE EACH
T3-032-01	#1	x	1-1/4"	PHILLIPS INSERT	\$0.83
T3-032-02	#2	x	1-1/4"	PHILLIPS INSERT	\$0.83
T3-032-03	#3	x	1-1/4"	PHILLIPS INSERT	\$0.83

PHILLIPS® INSERT BITS



5/16" HEX SHANK



PART NUMBER	POINT SIZE	x	LENGTH	DESCRIPTION	PRICE EACH
T3-R25-00	#0	x	1"	SQUARE RECESS INSERT	\$0.61
T3-R25-01	#1	x	1"	SQUARE RECESS INSERT	\$0.56
T3-R25-02	#2	x	1"	SQUARE RECESS INSERT	\$0.56
T3-R25-03	#3	x	1"	SQUARE RECESS INSERT	\$0.56

SQUARE RECESS INSERT BITS



1/4" HEX SHANK



PART NUMBER	POINT SIZE	x	LENGTH	DESCRIPTION	PRICE EACH
T3-R50-01	#1	x	2"	SQUARE RECESS POWER	\$1.06
T3-R70-01	#1	x	2-3/4"	SQUARE RECESS POWER	\$1.28
T3-R75-01	#1	x	3"	SQUARE RECESS POWER	\$1.67
T3-R90-01	#1	x	3-1/2"	SQUARE RECESS POWER	\$1.72
T3-R10-01	#1	x	4"	SQUARE RECESS POWER	\$1.58
T3-R12-01	#1	x	5"	SQUARE RECESS POWER	\$2.61
T3-R15-01	#1	x	6"	SQUARE RECESS POWER	\$3.67

SQUARE RECESS INSERT BITS



1/4" HEX SHANK



T3-R50-02	#2	x	2"	SQUARE RECESS POWER	\$1.06
T3-R65-02	#2	x	2-1/2"	SQUARE RECESS POWER	\$1.11
T3-R70-02	#2	x	2-3/4"	SQUARE RECESS POWER	\$1.28
T3-R75-02	#2	x	3"	SQUARE RECESS POWER	\$1.67
T3-R90-02	#2	x	3-1/2"	SQUARE RECESS POWER	\$1.72
T3-R10-02	#2	x	4"	SQUARE RECESS POWER	\$1.58
T3-R12-02	#2	x	5"	SQUARE RECESS POWER	\$2.61
T3-R15-02	#2	x	6"	SQUARE RECESS POWER	\$3.67

T3-R50-03	#3	x	2"	SQUARE RECESS POWER	\$1.06
T3-R70-03	#3	x	2-3/4"	SQUARE RECESS POWER	\$1.28
T3-R75-03	#3	x	3"	SQUARE RECESS POWER	\$1.67
T3-R90-03	#3	x	3-1/2"	SQUARE RECESS POWER	\$1.72
T3-R10-03	#3	x	4"	SQUARE RECESS POWER	\$1.58
T3-R12-03	#3	x	5"	SQUARE RECESS POWER	\$2.61
T3-R15-03	#3	x	6"	SQUARE RECESS POWER	\$3.67

SPECIAL ITEM

SQUARE RECESS POWER BIT FOR ROOF / FLOORING INSTALLATION TOOLS.

PART NUMBER	POINT SIZE	x	LENGTH	PRICE EACH
T3-R11-02	#2	x	4-3/4"	\$1.78

PHILLIPS® IS A REGISTERED TRADEMARK OF PHILLIPS SCREW Co.

MAIN OFFICE
 INTERNATIONAL TOOL MANUFACTURING
 71-08 51ST. AVENUE, WOODSIDE, NY 11377
 (718) 446-0711 • (800) 247-5696 • FAX (718) 899-6553



INTERNATIONAL TOOL MANUFACTURING
 675-E-PROGRESS CENTER AVE., LAWRENCEVILLE, GA 30043
 (770) 962-5454 • (800) 229-1776 • FAX (770) 962-5869

INDUSTRIAL SCREWDRIVER BITS



POZIDRIV® INSERT BITS

1/4" HEX SHANK



PART NUMBER	POINT SIZE	x	LENGTH	DESCRIPTION	PRICE EACH
PZ-025-01	#1	x	1"	POZIDRIV INSERT	\$0.61
PZ-025-02	#2	x	1"	POZIDRIV INSERT	\$0.61
PZ-025-03	#3	x	1"	POZIDRIV INSERT	\$0.61



POZIDRIV® POWER BITS

1/4" HEX SHANK



PART NUMBER	POINT SIZE	x	LENGTH	DESCRIPTION	PRICE EACH
PZ-050-01	#1	x	2"	POZIDRIV POWER	\$0.97
PZ-050-02	#2	x	2"	POZIDRIV POWER	\$0.97
PZ-075-02	#2	x	3"	POZIDRIV POWER	\$0.97
PZ-050-03	#3	x	2"	POZIDRIV POWER	\$0.97



STAR INSERT BITS FOR TORX® SCREWS

1/4" HEX SHANK



PART NUMBER	POINT SIZE	x	LENGTH	DESCRIPTION	PRICE EACH
TX-025-06	T6	x	1"	STAR INSERT	\$0.61
TX-025-07	T7	x	1"	STAR INSERT	\$0.61
TX-025-08	T8	x	1"	STAR INSERT	\$0.61
TX-025-09	T9	x	1"	STAR INSERT	\$0.61
TX-025-10	T10	x	1"	STAR INSERT	\$0.61
TX-025-15	T15	x	1"	STAR INSERT	\$0.61
TX-025-20	T20	x	1"	STAR INSERT	\$0.61
TX-025-25	T25	x	1"	STAR INSERT	\$0.61
TX-025-27	T27	x	1"	STAR INSERT	\$0.61
TX-025-30	T30	x	1"	STAR INSERT	\$0.61
TX-025-40	T40	x	1"	STAR INSERT	\$0.61



STAR POWER BITS FOR TORX® SCREWS

1/4" HEX SHANK



PART NUMBER	POINT SIZE	x	LENGTH	DESCRIPTION	PRICE EACH
TX-050-10	T10	x	2"	STAR POWER	\$0.78
TX-050-15	T15	x	2"	STAR POWER	\$0.78
TX-050-20	T20	x	2"	STAR POWER	\$0.78
TX-050-25	T25	x	2"	STAR POWER	\$0.78
TX-050-27	T27	x	2"	STAR POWER	\$0.78
TX-050-30	T30	x	2"	STAR POWER	\$0.78
TX-050-40	T40	x	2"	STAR POWER	\$0.78

POZIDRIV® IS A REGISTERED TRADEMARK OF PHILLIPS SCREW Co.
 TORX® IS A REGISTERED TRADEMARK OF CAMCAR, DIV. OF TEXTRON.

MAIN OFFICE
INTERNATIONAL TOOL MANUFACTURING
71-08 51ST. AVENUE, WOODSIDE, NY 11377
(718) 446-0711 • (800) 247-5696 • FAX (718) 899-6553



INTERNATIONAL TOOL MANUFACTURING
675-E-PROGRESS CENTER AVE., LAWRENCEVILLE, GA 30043
(770) 962-5454 • (800) 229-1776 • FAX (770) 962-5869

INDUSTRIAL SCREW DRIVER BITS

PART NUMBER	POINT SIZE	x	LENGTH	DESCRIPTION	PRICE EACH
TX-032-30	T30	x	1-1/4"	STAR INSERT	\$1.36
TX-032-40	T40	x	1-1/4"	STAR INSERT	\$1.36
TX-032-45	T45	x	1-1/4"	STAR INSERT	\$1.36
TX-032-50	T50	x	1-1/4"	STAR INSERT	\$1.36
TX-032-55	T55	x	1-1/4"	STAR INSERT	\$1.36

**STAR INSERT BITS
FOR TORX® SCREWS**
5/16" HEX SHANK



PART NUMBER	POINT SIZE	x	LENGTH	DESCRIPTION	PRICE EACH
HE-25-564	5/64"	x	1"	HEX INSERT	\$0.64
HE-25-332	3/32"	x	1"	HEX INSERT	\$0.64
HE-25-764	7/64"	x	1"	HEX INSERT	\$0.64
HE-25-864	1/8"	x	1"	HEX INSERT	\$0.64
HE-25-532	5/32"	x	1"	HEX INSERT	\$0.64
HE-25-316	3/16"	x	1"	HEX INSERT	\$0.64

HEX INSERT BITS
1/4" HEX SHANK



PART NUMBER	POINT SIZE	x	LENGTH	DESCRIPTION	PRICE EACH
HE-32-316	3/16"	x	1-1/4"	HEX INSERT	\$0.94
HE-32-732	7/32"	x	1-1/4"	HEX INSERT	\$0.94
HE-32-014	1/4"	x	1-1/4"	HEX INSERT	\$0.94

HEX INSERT BITS
5/16" HEX SHANK



PART NUMBER	POINT SIZE	x	LENGTH	DESCRIPTION	PRICE EACH
HE-25-020	2.0 mm	x	1"	HEX INSERT	\$0.92
HE-25-025	2.5 mm	x	1"	HEX INSERT	\$0.92
HE-25-030	3.0 mm	x	1"	HEX INSERT	\$0.92
HE-25-040	4.0 mm	x	1"	HEX INSERT	\$0.92
HE-25-050	5.0 mm	x	1"	HEX INSERT	\$0.92
HE-25-060	6.0 mm	x	1"	HEX INSERT	\$0.92

METRIC HEX INSERT BITS
1/4" HEX SHANK



TORX® IS A REGISTERED TRADEMARK OF CAMCAR, DIV. OF TEXTRON.

MAIN OFFICE
 INTERNATIONAL TOOL MANUFACTURING
 71-08 51ST. AVENUE, WOODSIDE, NY 11377
 (718) 446-0711 • (800) 247-5696 • FAX (718) 899-6553



INTERNATIONAL TOOL MANUFACTURING
 675-E-PROGRESS CENTER AVE., LAWRENCEVILLE, GA 30043
 (770) 962-5454 • (800) 229-1776 • FAX (770) 962-5869

INDUSTRIAL SCREWDRIVER BITS



1/4" HEX SHANK

SLOTTED INSERT BITS



PART NUMBER	POINT SIZE	x	LENGTH	BLADE THICKNESS		BLADE WIDTH		DESCRIPTION	PRICE EACH
				INCH	MM	INCH	MM		
ST-025-04	#4-5	x	1"	.034	.86	3/16"	4.8	SLOTTED INSERT	\$0.47
ST-025-08	#6-8	x	1"	.040	1.02	7/32"	5.6	SLOTTED INSERT	\$0.47
ST-025-10	#8-10	x	1"	.042	1.07	1/4"	6.4	SLOTTED INSERT	\$0.47
ST-025-12	#10-12	x	1"	.046	1.17	1/4"	6.4	SLOTTED INSERT	\$0.47



1/4" HEX SHANK

SLOTTED POWER BITS



PART NUMBER	POINT SIZE	x	LENGTH	BLADE THICKNESS		BLADE WIDTH		DESCRIPTION	PRICE EACH
				INCH	MM	INCH	MM		
ST-050-04	#4-5	x	2"	.034	.86	3/16"	4.8	SLOTTED POWER	\$0.97
ST-050-08	#6-8	x	2"	.040	1.02	7/32"	5.6	SLOTTED POWER	\$0.97
ST-050-10	#8-10	x	2"	.042	1.07	1/4"	6.4	SLOTTED POWER	\$0.97
ST-070-10	#8-10	x	3"	.042	1.07	1/4"	6.4	SLOTTED POWER	\$1.47
ST-090-10	#8-10	x	3-1/2"	.042	1.07	1/4"	6.4	SLOTTED POWER	\$1.61
ST-101-10	#8-10	x	4"	.042	1.07	1/4"	6.4	SLOTTED POWER	\$1.81
ST-150-10	#8-10	x	6"	.042	1.07	1/4"	6.4	SLOTTED POWER	\$3.48
ST-050-12	#10-12	x	2"	.046	1.17	1/4"	6.4	SLOTTED POWER	\$0.97



1/4" HEX SHANK

SLOTTED POWER BITS WITH FINDERS



PART NUMBER	POINT SIZE	x	LENGTH	A	B	C	DESCRIPTION	PRICE EACH
				NOSE DIA.	NOSE LENGTH	INSIDE CLEARANCE		
BF-050-08	#6-8	x	2"	7/16"	15/16"	.22	SLOTTED BIT FINDER	\$1.06
BF-050-10	#8-10	x	2"	7/16"	15/16"	.31	SLOTTED BIT FINDER	\$1.06
BF-050-12	#10-12	x	2"	7/16"	15/16"	.31	SLOTTED BIT FINDER	\$1.06

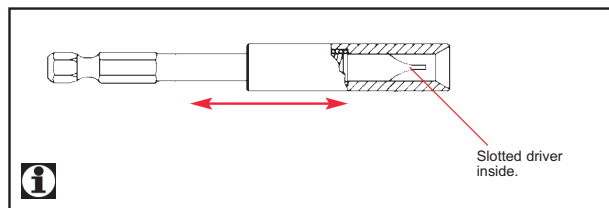

MAIN OFFICE
INTERNATIONAL TOOL MANUFACTURING
71-08 51ST. AVENUE, WOODSIDE, NY 11377
(718) 446-0711 • (800) 247-5696 • FAX (718) 899-6553



INTERNATIONAL TOOL MANUFACTURING
675-E-PROGRESS CENTER AVE., LAWRENCEVILLE, GA 30043
(770) 962-5454 • (800) 229-1776 • FAX (770) 962-5869

INDUSTRIAL SCREW DRIVER BITS

METRIC SLOTTED INSERT BITS

PART NUMBER	POINT SIZE	x	LENGTH	DESCRIPTION	PRICE EACH
ST-M25-05	5mm X .8mm	x	1"	SLOTTED INSERT	\$0.42
ST-M25-06	6mm X 1.0mm	x	1"	SLOTTED INSERT	\$0.42
ST-M25-08	8mm X 1.2mm	x	1"	SLOTTED INSERT	\$0.42
ST-M25-10	10mm X 1.5mm	x	1"	SLOTTED INSERT	\$0.42

1/4" HEX SHANK



METRIC SLOTTED POWER BITS

PART NUMBER	POINT SIZE	x	LENGTH	DESCRIPTION	PRICE EACH
ST-M50-05	5mm X .8mm	x	2"	SLOTTED POWER	\$0.61
ST-M50-06	6mm X 1.0mm	x	2"	SLOTTED POWER	\$0.61
ST-M50-08	8mm X 1.2mm	x	2"	SLOTTED POWER	\$0.78
ST-M50-10	10mm X 1.5mm	x	2"	SLOTTED POWER	\$0.92

1/4" HEX SHANK



DOUBLE END INSERT BITS

PART NUMBER	POINT 1	x	POINT 2	x	LENGTH	DESCRIPTION	PRICE EACH
DW-050-23	#1 PHILLIPS	x	6-8 SLOTTED	x	1-9/16"	DOUBLE END	\$0.72
DW-050-26	#2 PHILLIPS	x	6-8 SLOTTED	x	1-9/16"	DOUBLE END	\$0.72
DW-050-28	#2 PHILLIPS	x	8-10 SLOTTED	x	1-9/16"	DOUBLE END	\$0.72
DW-050-30	#2 PHILLIPS	x	10-12 SLOTTED	x	1-9/16"	DOUBLE END	\$0.72
DW-050-21	#2 PHILLIPS	x	#1 PHILLIPS	x	1-9/16"	DOUBLE END	\$0.72
DW-050-22	#2 PHILLIPS	x	#2 PHILLIPS	x	1-9/16"	DOUBLE END	\$0.72
DW-050-24	#3 PHILLIPS	x	10-12 SLOTTED	x	1-9/16"	DOUBLE END	\$0.72

1/4" HEX SHANK



QUI0001
QUICKY
1/4" SHANK QUICK RELEASE
ADAPTER
 List Price \$5.50 / each



- Carded.
- Fits In Any Drill or Screw Driver Handle.
- Designed To Work With Any Power Bit.



MAIN OFFICE
 INTERNATIONAL TOOL MANUFACTURING
 71-08 51ST. AVENUE, WOODSIDE, NY 11377
 (718) 446-0711 • (800) 247-5696 • FAX (718) 899-6553



INTERNATIONAL TOOL MANUFACTURING
 675-E-PROGRESS CENTER AVE., LAWRENCEVILLE, GA 30043
 (770) 962-5454 • (800) 229-1776 • FAX (770) 962-5869

INDUSTRIAL TAMPER RESISTANT BITS



SPANNER INSERT BITS TAMPER RESISTANT

1/4" HEX SHANK



PART NUMBER	POINT SIZE	x	LENGTH	DESCRIPTION	PRICE EACH
SP-025-06	#6	x	1"	SPANNER	\$1.61
SP-025-08	#8	x	1"	SPANNER	\$1.61
SP-025-10	#10	x	1"	SPANNER	\$1.61
SP-025-12	#12	x	1"	SPANNER	\$1.61
SP-025-14	#14	x	1"	SPANNER	\$1.91



STAR INSERT BITS FOR TAMPER RESISTANT TORX® SCREWS

1/4" HEX SHANK



PART NUMBER	POINT SIZE	x	LENGTH	DESCRIPTION	PRICE EACH
TT-025-08	T8	x	1"	STAR TAMPER R.	\$1.44
TT-025-09	T9	x	1"	STAR TAMPER R.	\$1.44
TT-025-10	T10	x	1"	STAR TAMPER R.	\$1.44
TT-025-15	T15	x	1"	STAR TAMPER R.	\$1.44
TT-025-20	T20	x	1"	STAR TAMPER R.	\$1.44
TT-025-25	T25	x	1"	STAR TAMPER R.	\$1.44
TT-025-27	T27	x	1"	STAR TAMPER R.	\$1.44
TT-025-30	T30	x	1"	STAR TAMPER R.	\$1.44
TT-025-40	T40	x	1"	STAR TAMPER R.	\$1.44



STAR INSERT BITS FOR TAMPER RESISTANT TORX® SCREWS

5/16" HEX SHANK



PART NUMBER	POINT SIZE	x	LENGTH	DESCRIPTION	PRICE EACH
TT-032-45	T45	x	1-1/4"	STAR TAMPER R.	\$2.14
TT-032-50	T50	x	1-1/4"	STAR TAMPER R.	\$2.14
TT-032-55	T55	x	1-1/4"	STAR TAMPER R.	\$2.14



HEX INSERT BITS TAMPER RESISTANT

1/4" HEX SHANK



TAMPER PROOF SCREWS

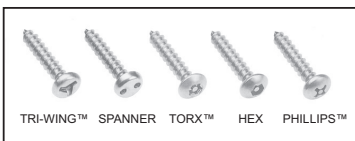

TRI-WING™ SPANNER TORX™ HEX PHILLIPS™

PART NUMBER	POINT SIZE	x	LENGTH	DESCRIPTION	PRICE EACH
TH-25-332	3/32"	x	1"	HEX TAMPER R.	\$1.42
TH-25-018	1/8"	x	1"	HEX TAMPER R.	\$1.42
TH-25-964	9/64"	x	1"	HEX TAMPER R.	\$1.42
TH-25-532	5/32"	x	1"	HEX TAMPER R.	\$1.42
TH-25-316	3/16"	x	1"	HEX TAMPER R.	\$1.42
TH-25-732	7/32"	x	1"	HEX TAMPER R.	\$1.42
TH-25-014	1/4"	x	1"	HEX TAMPER R.	\$1.42
TH-25-516	5/16"	x	1"	HEX TAMPER R.	\$1.42

TORX® IS A REGISTERED TRADEMARK OF CAMCAR, DIV. OF TEXTRON.

MAIN OFFICE
INTERNATIONAL TOOL MANUFACTURING
71-08 51ST. AVENUE, WOODSIDE, NY 11377
(718) 446-0711 • (800) 247-5696 • FAX (718) 899-6553



INTERNATIONAL TOOL MANUFACTURING
675-E-PROGRESS CENTER AVE., LAWRENCEVILLE, GA 30043
(770) 962-5454 • (800) 229-1776 • FAX (770) 962-5869

INDUSTRIAL TAMPER RESISTANT BITS

PART NUMBER	POINT SIZE	x	LENGTH	DESCRIPTION	PRICE EACH
TRI-25-01	#1	x	1"	TRI-WING	\$1.42
TRI-25-02	#2	x	1"	TRI-WING	\$1.42
TRI-25-03	#3	x	1"	TRI-WING	\$1.42

**TRI-WING® INSERT BITS
TAMPER RESISTANT**



1/4" HEX SHANK



PART NUMBER	POINT SIZE	x	LENGTH	DESCRIPTION	PRICE EACH
TP-025-02	#2	x	1"	PHILLIPS TAMPER	\$2.75
TP-025-03	#3	x	1"	PHILLIPS TAMPER	\$2.75

**PHILLIPS® INSERT BITS
TAMPER RESISTANT**



1/4" HEX SHANK



PART NUMBER	POINT SIZE	DESCRIPTION	PRICE EACH
TT-K10-10	T10	STAR TAMPER RES. SHORT ARM KEY	\$2.28
TT-K10-15	T15	STAR TAMPER RES. SHORT ARM KEY	\$2.28
TT-K10-20	T20	STAR TAMPER RES. SHORT ARM KEY	\$2.28
TT-K10-25	T25	STAR TAMPER RES. SHORT ARM KEY	\$2.28
TT-K10-27	T27	STAR TAMPER RES. SHORT ARM KEY	\$2.28
TT-K10-30	T30	STAR TAMPER RES. SHORT ARM KEY	\$2.28
TT-K10-40	T40	STAR TAMPER RES. SHORT ARM KEY	\$2.28

**STAR SHORT ARM KEYS
FOR TAMPER RESISTANT TORX® SCREWS**



1/4" HEX SHANK



30 PC. TAMPER RESISTANT INSERT BIT SET

PART NUMBER	DESCRIPTION	PRICE EACH
TR-100-30	30 PIECE TAMPER RESISTANT INSERT SET WITH CASE & HANDLE	\$47.19
	#6, #8, #10 SPANNER 3/32", 1/8", 9/64", 5/32" -	
	#1, #2, #3 POZIDRIV 3/16", 7/32", 1/4", 5/16" HEX	
	#1, #2, #3 TRI-WING	
	1" LONG SOCKET ADAPTER T8, T9, T10, T15, T20, T25 -	
	3" LONG BIT HOLDER T27, T30, T40 STAR	



TRI-WING® IS A REGISTERED TRADEMARK OF PHILLIPS SCREW Co.
 TORX® IS A REGISTERED TRADEMARK OF CAMCAR, DIV. OF TEXTRON.

MAIN OFFICE
 INTERNATIONAL TOOL MANUFACTURING
 71-08 51ST. AVENUE, WOODSIDE, NY 11377
 (718) 446-0711 • (800) 247-5696 • FAX (718) 899-6553



INTERNATIONAL TOOL MANUFACTURING
 675-E-PROGRESS CENTER AVE., LAWRENCEVILLE, GA 30043
 (770) 962-5454 • (800) 229-1776 • FAX (770) 962-5869

ACR® SCREW DRIVER BITS

i ACR® Insert & Power bits have interlocking ribs that provide greater torque and grip when used with most heat treated and case hardened screws. ACR® insert bits will work with all 1/4" bit holders and are interchangeable with all standard screw driver bit components.



PHILLIPS® ACR® INSERT BITS

1/4" HEX SHANK



PART NUMBER	POINT SIZE	x	LENGTH	DESCRIPTION	PRICE EACH
ACR-025-01	#1	x	1"	ACR PHILLIPS INSERT	\$0.52
ACR-025-02	#2	x	1"	ACR PHILLIPS INSERT	\$0.43
ACR-025-03	#3	x	1"	ACR PHILLIPS INSERT	\$0.46



SLOTTED ACR® INSERT BITS

1/4" HEX SHANK



PART NUMBER	POINT SIZE	x	LENGTH	DESCRIPTION	PRICE EACH
ACR-025-04	#4-5	x	1"	ACR SLOTTED INSERT	\$0.52
ACR-025-08	#6-8	x	1"	ACR SLOTTED INSERT	\$0.52
ACR-025-10	#8-10	x	1"	ACR SLOTTED INSERT	\$0.52
ACR-025-12	#10-12	x	1"	ACR SLOTTED INSERT	\$0.52



PHILLIPS® ACR® POWER BITS

1/4" HEX SHANK



PART NUMBER	POINT SIZE	x	LENGTH	DESCRIPTION	PRICE EACH
ACR-050-01	#1	x	2"	ACR PHILLIPS POWER	\$0.83
ACR-050-02	#2	x	2"	ACR PHILLIPS POWER	\$0.83
ACR-050-03	#3	x	2"	ACR PHILLIPS POWER	\$0.83

ACR® IS A REGISTERED TRADEMARK OF PHILLIPS SCREW COMPANY.

MAIN OFFICE
INTERNATIONAL TOOL MANUFACTURING
 71-08 51ST. AVENUE, WOODSIDE, NY 11377
 (718) 446-0711 • (800) 247-5696 • FAX (718) 899-6553



INTERNATIONAL TOOL MANUFACTURING
 675-E-PROGRESS CENTER AVE., LAWRENCEVILLE, GA 30043
 (770) 962-5454 • (800) 229-1776 • FAX (770) 962-5869



THE STOPPER™

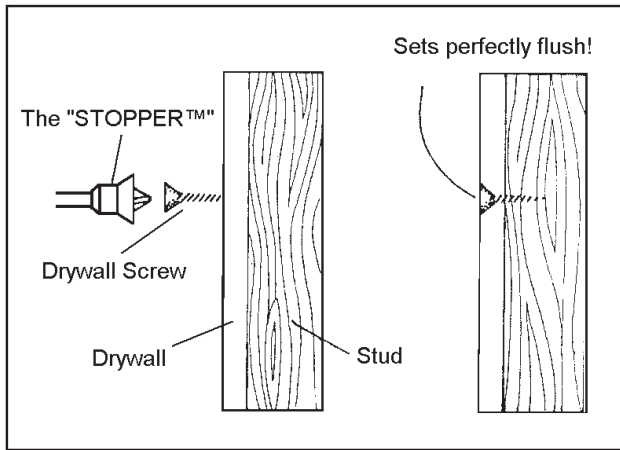

PART # **PRICE**
SP-025-2P **\$1.42**
 #2 X 1" Phillips® With 9/16" Collar

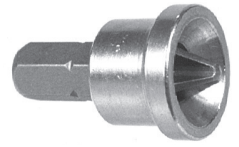

Star #40
TX-025-40P
\$2.51 / Ea.

For Flat Bed Screws
 Need another style bit
 inside The Stopper?
 Ask us how we can
 help.

- Stops damage to drywall.
- Sets drywall screws perfectly flush.
- Works perfectly every time.
- Use in any bit holder.
- Use any drill machine Rotation Only.
- 9/16" Collar Diameter.

250PC. STOPPER™ Jar Available on Page 103.

PATENT # 5101698

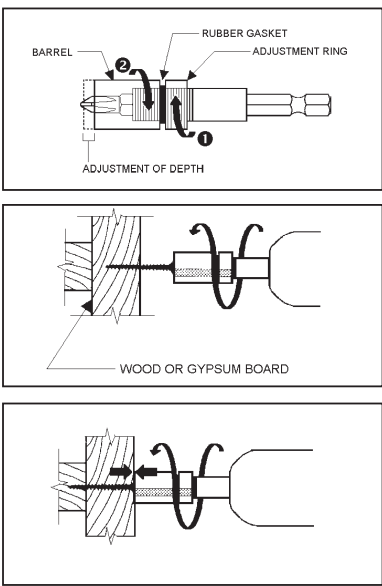

THE POWER STOPPER™

- Prevents overdriving screws into material.
- Reduces tip wear.
- Magnetic set inside Stopper for holding screws.
- Set & lock for adjustable depth.
- 1/4" drive for use in any machine & any tip.



PART # **PRICE**
DC-075-01 **\$9.84**

1/4" x 3" Adjustable Depth Bit Holder. Tips not included.

CEILING TILE HANGER DRIVER / LAG DRIVER

PART NUMBER	SIZE	DESCRIPTION	PRICE EACH
CE-075-14SL	7/16" X 2-3/16"	LAG DRIVER WITH SLEEVE	\$3.19

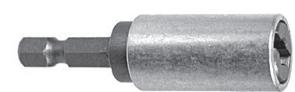

MAIN OFFICE
 INTERNATIONAL TOOL MANUFACTURING
 71-08 51ST. AVENUE, WOODSIDE, NY 11377
 (718) 446-0711 • (800) 247-5696 • FAX (718) 899-6553



INTERNATIONAL TOOL MANUFACTURING
 675-E-PROGRESS CENTER AVE., LAWRENCEVILLE, GA 30043
 (770) 962-5454 • (800) 229-1776 • FAX (770) 962-5869

SCREWDRIVER BIT HOLDERS

STAINLESS STEEL MAGNETIC BIT HOLDERS FOR ALL 1/4" INSERTS

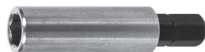

PART NUMBER	LENGTH	BODY DIA.	RETAINING RING	DESCRIPTION	PRICE EACH
BH-020-RC	1-3/4"	7/16"	NO	2PC. CONSTRUCTION	\$5.33



PART NUMBER	LENGTH	BODY DIA.	RETAINING RING	DESCRIPTION	PRICE EACH
BH-040-RC	1-13/16"	7/16"	YES	1PC. CONSTRUCTION	\$4.48



PART NUMBER	LENGTH	BODY DIA.	RETAINING RING	DESCRIPTION	PRICE EACH
BH-060-RC	2-5/8"	7/16"	YES	1PC. CONSTRUCTION	\$4.31

BH-060-40 made of Chrome Vanadium.



PART NUMBER	LENGTH	BODY DIA.	RETAINING RING	DESCRIPTION	PRICE EACH
BH-060-40	2-5/8"	3/8"	NO	2PC. CONSTRUCTION	\$3.03



PART NUMBER	LENGTH	BODY DIA.	RETAINING RING	DESCRIPTION	PRICE EACH
BH-075-14	3"	7/16"	NO	2PC. CONSTRUCTION	\$4.50



PART NUMBER	LENGTH	BODY DIA.	RETAINING RING	DESCRIPTION	PRICE EACH
BH-075-14R	3"	7/16"	YES	2PC. CONSTRUCTION	\$4.72



PART NUMBER	LENGTH	BODY DIA.	RETAINING RING	DESCRIPTION	PRICE EACH
BH-075-RC	3"	7/16"	YES	1PC. CONSTRUCTION	\$4.72



PART NUMBER	LENGTH	BODY DIA.	RETAINING RING	DESCRIPTION	PRICE EACH
BH-100-TR	3"	7/16"	THREADED	1PC. CONSTRUCTION	\$10.19



PART NUMBER	LENGTH	BODY DIA.	RETAINING RING	DESCRIPTION	PRICE EACH
BH-100-RC	4"	7/16"	YES	1PC. CONSTRUCTION	\$8.33



PART NUMBER	LENGTH	BODY DIA.	RETAINING RING	DESCRIPTION	PRICE EACH
BH-150-RC	6"	7/16"	YES	1PC. CONSTRUCTION	\$15.97

MAIN OFFICE
INTERNATIONAL TOOL MANUFACTURING
 71-08 51ST. AVENUE, WOODSIDE, NY 11377
 (718) 446-0711 • (800) 247-5696 • FAX (718) 899-6553



INTERNATIONAL TOOL MANUFACTURING
 675-E-PROGRESS CENTER AVE., LAWRENCEVILLE, GA 30043
 (770) 962-5454 • (800) 229-1776 • FAX (770) 962-5869

BIT HOLDERS / HANGER BOLT

SPECIAL APPLICATION MAGNETIC BIT HOLDERS FOR ALL 1/4" INSERTS

PART NUMBER	LENGTH	BODY DIA.	RETAINING RING	DESCRIPTION	PRICE EACH
BH-050-LK	2"	9/16"	YES / LOCK	SNAP LOCK HOLDER	\$6.53
BH-075-LK	3"	9/16"	YES / LOCK	SNAP LOCK HOLDER	\$8.75



Pull back system locks in bits.

PART NUMBER	LENGTH	BODY DIA.	RETAINING RING	DESCRIPTION	PRICE EACH
BH-075-SL	3"	7/16"	NO	SLEEVE GUIDE HOLDER	\$5.20
BH-125-SL	5"	7/16"	NO	SLEEVE GUIDE HOLDER	\$5.50



Sleeve extends up to 8" to hold screw while fastening.

PART NUMBER	LENGTH	BODY DIA.	RETAINING RING	DESCRIPTION	PRICE EACH
FX-075-01	7-1/4"	1/2"	YES / BALL	FLEXIBLE BIT HOLDER	\$12.75



Flexible shaft can bend up to 90° for those hard to get at areas.

PART NUMBER	LENGTH	BODY DIA.	RETAINING RING	DESCRIPTION	PRICE EACH
QUI0001	1-3/4"	13/16"	LOCK	LOCK / SPRING OUT ALL METAL CONSTRUCTION	\$5.50
CH-060-01	1-3/4"	13/16"	LOCK	LOCK / SPRING OUT METAL / PLASTIC	\$4.25



This chuck has a quick insert / quick spring out system for easy bit changing. Locks in bits. For 2"+ POWER bits only!!!

HANGER BOLT DRIVERS WITH 1/4" POWER HEX SHANKS

PART NUMBER	LENGTH	HEAD DIA.	THREAD SIZE	DESCRIPTION	PRICE EACH
HB-50-038	1-7/8"	9/16"	3/8" - 16	HANGER BOLT DRIVER	\$5.58
HB-75-038	2-9/16"	9/16"	3/8" - 16	HANGER BOLT DRIVER	\$6.06



Internal Threads for Driving Hanger Bolts and Threaded Rod.

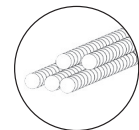

MAIN OFFICE
INTERNATIONAL TOOL MANUFACTURING
71-08 51ST. AVENUE, WOODSIDE, NY 11377
(718) 446-0711 • (800) 247-5696 • FAX (718) 899-6553



INTERNATIONAL TOOL MANUFACTURING
675-E-PROGRESS CENTER AVE., LAWRENCEVILLE, GA 30043
(770) 962-5454 • (800) 229-1776 • FAX (770) 962-5869

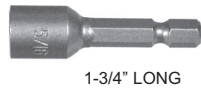
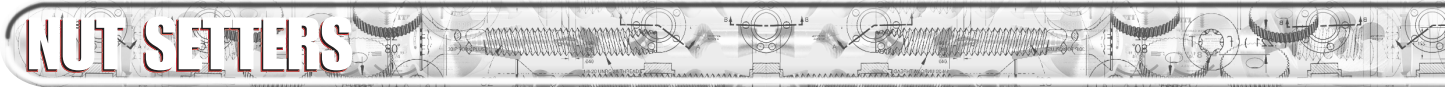

1-3/4" LONG



2-1/8" LONG



2-9/16" LONG



4" LONG

- 1PC. CONSTRUCTION
- 1/4" HEX SHANK

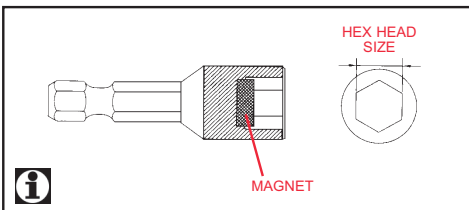

MAGNETIC NUT SETTERS

PART NUMBER	HEX HEAD SIZE	x	LENGTH	DESCRIPTION	PRICE EACH
NS-042-16	1/4"	x	1-3/4"	MAG. NUT SETTER	\$2.39
NS-053-16	1/4"	x	2-1/8"	MAG. NUT SETTER	\$2.66
NS-065-16	1/4"	x	2-9/16"	MAG. NUT SETTER	\$2.86
NS-075-16	1/4"	x	4"	MAG. NUT SETTER	\$6.14
NS-085-16	1/4"	x	6"	MAG. NUT SETTER	\$7.53
NS-042-20	5/16"	x	1-3/4"	MAG. NUT SETTER	\$2.53
NS-053-20	5/16"	x	2-1/8"	MAG. NUT SETTER	\$2.89
NS-065-20	5/16"	x	2-9/16"	MAG. NUT SETTER	\$3.14
NS-075-20	5/16"	x	4"	MAG. NUT SETTER	\$7.06
NS-085-20	5/16"	x	6"	MAG. NUT SETTER	\$10.86
NS-042-24	3/8"	x	1-3/4"	MAG. NUT SETTER	\$3.22
NS-053-24	3/8"	x	2-1/8"	MAG. NUT SETTER	\$3.99
NS-065-24	3/8"	x	2-9/16"	MAG. NUT SETTER	\$4.17
NS-075-24	3/8"	x	4"	MAG. NUT SETTER	\$8.08
NS-085-24	3/8"	x	6"	MAG. NUT SETTER	\$13.58
NS-042-28	7/16"	x	1-3/4"	MAG. NUT SETTER	\$6.64
NS-053-28	7/16"	x	2-1/8"	MAG. NUT SETTER	\$7.25
NS-065-28	7/16"	x	2-9/16"	MAG. NUT SETTER	\$7.56
NS-042-32	1/2"	x	1-3/4"	MAG. NUT SETTER	\$7.30
NS-065-32	1/2"	x	2-9/16"	MAG. NUT SETTER	\$8.32

MAGNETIC NUT SETTERS (LOBULAR)



FRONT VIEW



NEW

i Use Lobular Nut Setters on coated hex head screws and bolts to prevent paint stripping.

PART NUMBER	HEX HEAD SIZE	x	LENGTH	DESCRIPTION	PRICE EACH
LB-042-16	1/4"	x	1-3/4"	LOBULAR MAG. NUT SETTER	\$3.85
LB-065-16	1/4"	x	2-9/16"	LOBULAR MAG. NUT SETTER	\$4.15
LB-042-20	5/16"	x	1-3/4"	LOBULAR MAG. NUT SETTER	\$3.90
LB-065-20	5/16"	x	2-9/16"	LOBULAR MAG. NUT SETTER	\$4.45
LB-042-24	3/8"	x	1-3/4"	LOBULAR MAG. NUT SETTER	\$4.06
LB-065-24	3/8"	x	2-9/16"	LOBULAR MAG. NUT SETTER	\$4.92

MAIN OFFICE
INTERNATIONAL TOOL MANUFACTURING
71-08 51ST. AVENUE, WOODSIDE, NY 11377
(718) 446-0711 • (800) 247-5696 • FAX (718) 899-6553



INTERNATIONAL TOOL MANUFACTURING
675-E-PROGRESS CENTER AVE., LAWRENCEVILLE, GA 30043
(770) 962-5454 • (800) 229-1776 • FAX (770) 962-5869

SCREW DRIVER SETS

30 PC. INSERT BIT SET

PART NUMBER	DESCRIPTION	PRICE EACH
ST-100-30	30 PIECE INSERT SET WITH CASE & HANDLE #1, #2, #3 PHILLIPS® #0, #1, #2, #3 SQUARE 3-4, 4-5, 6-8, 8-10 SLOTTED 5/64", 3/32", 7/64", 1/8", 9/64" HEX T10, T15, T20, T25, T27, T30, T40 STAR #1, #2, #3 POSIDRIV® 1" LONG SOCKET ADAPTER 3" LONG MAGNETIC BIT HOLDER	\$35.97



Tamper Resistant Set Available on Page 93.



RED HANDLE

6-IN-1 COMBINATION SCREWDRIVER

PART NUMBER	DESCRIPTION	PRICE EACH
ST-100-20	6-IN-1 SCREW DRIVER #1, #2, PHILLIPS 1/4" NUT SETTER #5, #8-10, SLOTTED 5/16" NUT SETTER	\$7.25



SOLD IN 12 PIECE DISPLAY BOX ONLY

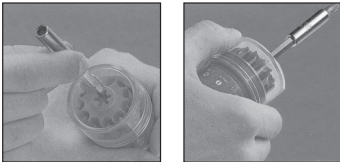

10 PIECE DIAL-A-BIT INSERT SET

PART NUMBER	DESCRIPTION	PRICE EACH
ST-100-08	10 PIECE INSERT SET #1, #2, #3 PHILLIPS #1, #2, #3 SQUARE #6-8, #8-10, #10-12 SLOTTED 2-5/8" BIT HOLDER	\$9.50



MAIN OFFICE
 INTERNATIONAL TOOL MANUFACTURING
 71-08 51ST. AVENUE, WOODSIDE, NY 11377
 (718) 446-0711 • (800) 247-5696 • FAX (718) 899-6553



INTERNATIONAL TOOL MANUFACTURING
 675-E-PROGRESS CENTER AVE., LAWRENCEVILLE, GA 30043
 (770) 962-5454 • (800) 229-1776 • FAX (770) 962-5869

SCREW DRIVER SETS

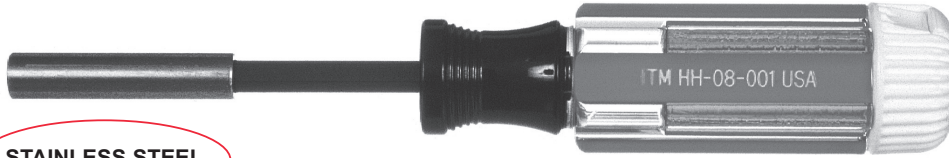

**STAINLESS STEEL
 SHAFT**



**MADE
 IN THE
 USA**

**1/4" DRIVE & 5/16" DRIVE MAGNETIC SCREW DRIVERS
 WITH INSERT BIT STORAGE HANDLES. BITS NOT INCLUDED.**

PART NUMBER	DRIVE	DESCRIPTION	PRICE EACH
HH-08-001	1/4"	8" MAGNETIC STORAGE HANDLE	\$7.65
HH-08-002	5/16"	8" MAGNETIC STORAGE HANDLE	\$11.25

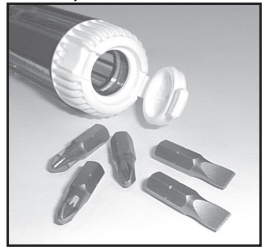

**1/4" DRIVE MAGNETIC SCREW DRIVERS WITH
 5 INSERT BITS IN STORAGE HANDLE**

PART NUMBER	CONTENTS					PRICE EACH
HH-08-100	#4-5 SLOTTED	#8-10 SLOTTED	#1 PHILLIPS	#2 PHILLIPS	#3 PHILLIPS	\$13.80
HH-08-200	#4-5 SLOTTED	#8-10 SLOTTED	#1 PHILLIPS	#2 PHILLIPS	#15 STAR	\$13.80
HH-08-300	#4-5 SLOTTED	#8-10 SLOTTED	#1 PHILLIPS	#2 PHILLIPS	#2 SQUARE	\$13.80
HH-08-400	T15 STAR	T20 STAR	T25 STAR	T27 STAR	T30 STAR	\$13.80
HH-08-500	T15 STAR PIN	T20 STAR PIN	T25 STAR PIN	T27 STAR PIN	T30 STAR PIN	\$15.75
HH-08-600	#6 SPANNER	#8 SPANNER	#10 SPANNER	#12 SPANNER	#2 PHILLIPS	\$15.75

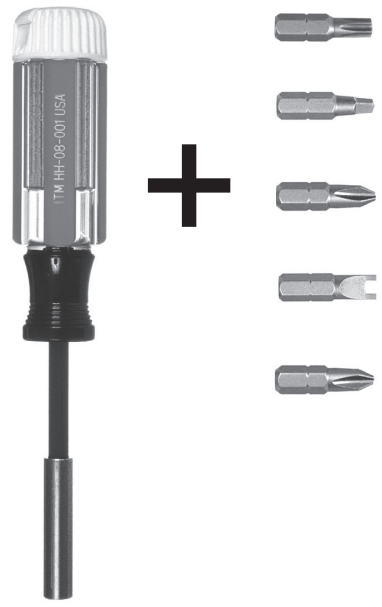

MAIN OFFICE
INTERNATIONAL TOOL MANUFACTURING
71-08 51ST. AVENUE, WOODSIDE, NY 11377
(718) 446-0711 • (800) 247-5696 • FAX (718) 899-6553



INTERNATIONAL TOOL MANUFACTURING
675-E-PROGRESS CENTER AVE., LAWRENCEVILLE, GA 30043
(770) 962-5454 • (800) 229-1776 • FAX (770) 962-5869

MEGAPRO - SCREWDRIVERS

15in1
Screwdriver

MEGAPRO+TM

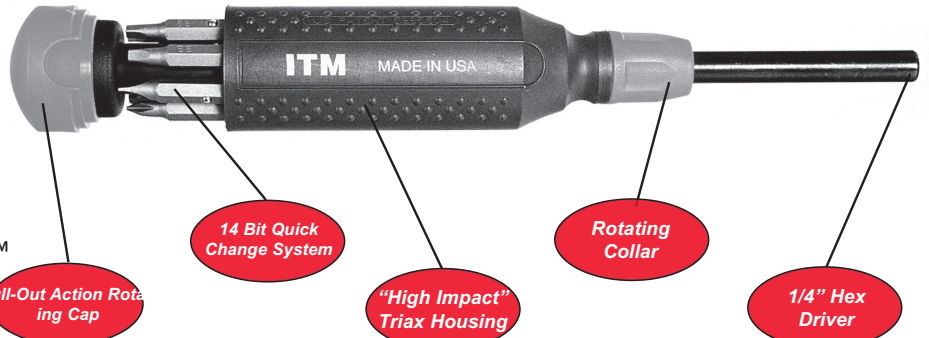

US PATENT 5265504

PART NUMBER	DESCRIPTION	PRICE EACH
MEGAPRO151	15-IN-1 MEGAPRO SCREW DRIVER #0 - #3 PHILLIPS #10 - #15 STAR #1 - #2 PHILLIPS #20 - #25 STAR #0 - #3 SQUARE #4 - #6 SLOTTED #1 - #2 SQUARE	\$36.50



FREE DISPLAY!!!
 WITH FIRST TIME PURCHASE OF 20 DRIVERS.
\$25 VALUE.

PART NUMBER	DESCRIPTION	PRICE EACH
MEGATAM151	15-IN-1 TAMPERPROOF SCREW DRIVER #6 - #8 SPANNER #10 - #15 STAR PIN #10 - #12 SPANNER #20 - #25 STAR PIN 1/8" - 9/64" HEX PIN #27 - #30 STAR PIN 5/32" - 3/16" HEX PIN	\$49.50



Tamper Proof Tamper Proof Driver sold Individually Pouched.

PART NUMBER	DESCRIPTION	PRICE EACH
470001	#0 - #3 PHILLIPS®	\$2.08
470002	#1 - #2 PHILLIPS®	\$2.08
470003	#0 - #3 SQUARE	\$2.08
470004	#1 - #2 SQUARE	\$2.08
470005	#10 - #15 STAR	\$2.08
470006	#20 - #25 STAR	\$2.08
470009	#27 - #30 STAR (SPECIAL SIZE)	\$2.08
470007	#4 - #6 SLOTTED	\$2.08
690001	#6 - #8 SPANNER	\$2.50
690002	#10 - #12 SPANNER	\$2.50
690003	1/8" - 9/64" HEX PIN	\$2.50
690004	5/32" - 3/16" HEX PIN	\$2.50
690005	#10 - #15 STAR PIN	\$2.50
690006	#20 - #25 STAR PIN	\$2.50
690007	#27 - #30 STAR PIN	\$2.50

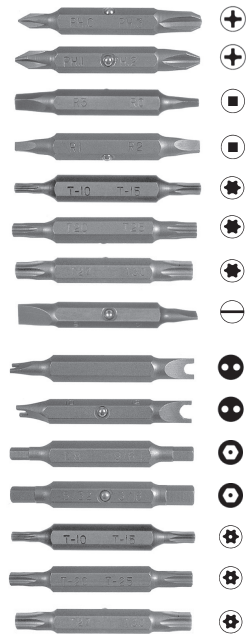

Replacement bits for the Megapro & Megapro Tamper Proof are sold individually.



MEGAPRO
MADE
IN
USA

PHILLIPS® IS A REGISTERED TRADEMARK OF PHILLIPS SCREW Co.

MAIN OFFICE
INTERNATIONAL TOOL MANUFACTURING
 71-08 51ST. AVENUE, WOODSIDE, NY 11377
 (718) 446-0711 • (800) 247-5696 • FAX (718) 899-6553



INTERNATIONAL TOOL MANUFACTURING
 675-E-PROGRESS CENTER AVE., LAWRENCEVILLE, GA 30043
 (770) 962-5454 • (800) 229-1776 • FAX (770) 962-5869

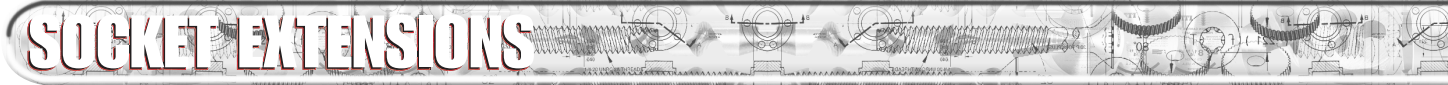

1/4"
DRIVE



1/4" SHANK TO FIT 1/4" SQUARE DRIVE

PART NUMBER	SHANK HEX SIZE	x	TOTAL LENGTH	x	MALE SQUARE	DESCRIPTION	PRICE EACH
AD-025-14	1/4"	x	1"	x	1/4"	SOCKET EXTENSION	\$1.09
AD-032-14	1/4"	x	1-1/4"	x	1/4"	SOCKET EXTENSION	\$1.14
AD-050-14	1/4"	x	2"	x	1/4"	SOCKET EXTENSION	\$1.55
AD-075-14	1/4"	x	3"	x	1/4"	SOCKET EXTENSION	\$2.19
AD-100-14	1/4"	x	4"	x	1/4"	SOCKET EXTENSION	\$2.80
AD-150-14	1/4"	x	6"	x	1/4"	SOCKET EXTENSION	\$3.40
AD-200-14	1/4"	x	8"	x	1/4"	SOCKET EXTENSION	\$4.14

3/8"
DRIVE



1/4" SHANK TO FIT 3/8" SQUARE DRIVE

PART NUMBER	SHANK HEX SIZE	x	TOTAL LENGTH	x	MALE SQUARE	DESCRIPTION	PRICE EACH
AD-050-38	1/4"	x	2"	x	3/8"	SOCKET EXTENSION	\$2.98
AD-075-38	1/4"	x	3"	x	3/8"	SOCKET EXTENSION	\$4.06
AD-100-38	1/4"	x	4"	x	3/8"	SOCKET EXTENSION	\$4.45
AD-150-38	1/4"	x	6"	x	3/8"	SOCKET EXTENSION	\$5.45
AD-200-38	1/4"	x	8"	x	3/8"	SOCKET EXTENSION	\$6.20

1/2"
DRIVE



1/4" SHANK TO FIT 1/2" SQUARE DRIVE

PART NUMBER	SHANK HEX SIZE	x	TOTAL LENGTH	x	MALE SQUARE	DESCRIPTION	PRICE EACH
AD-055-12	1/4"	x	2-1/8"	x	1/2"	SOCKET EXTENSION	\$4.50
AD-075-12	1/4"	x	3"	x	1/2"	SOCKET EXTENSION	\$4.95
AD-100-12	1/4"	x	4"	x	1/2"	SOCKET EXTENSION	\$5.10
AD-150-12	1/4"	x	6"	x	1/2"	SOCKET EXTENSION	\$6.12
AD-200-12	1/4"	x	8"	x	1/2"	SOCKET EXTENSION	\$8.14

MAIN OFFICE
INTERNATIONAL TOOL MANUFACTURING
71-08 51ST. AVENUE, WOODSIDE, NY 11377
(718) 446-0711 • (800) 247-5696 • FAX (718) 899-6553



INTERNATIONAL TOOL MANUFACTURING
675-E-PROGRESS CENTER AVE., LAWRENCEVILLE, GA 30043
(770) 962-5454 • (800) 229-1776 • FAX (770) 962-5869

MAGNETIC IMPACT SOCKETS

1/4" SQUARE DRIVE MAGNETIC IMPACT SOCKETS

PART NUMBER	SQUARE DRIVE	(A) LENGTH	HEX OPENING	(B) BODY	(C) NOSE	DESCRIPTION	PRICE EACH
250ST1264	1/4"	15/16"	3/16"	1/2"	3/8"	MAG. IMPACT SOCKET	\$3.59
250ST1664	1/4"	15/16"	1/4"	1/2"	7/16"	MAG. IMPACT SOCKET	\$3.59
250ST2064	1/4"	15/16"	5/16"	1/2"	1/2"	MAG. IMPACT SOCKET	\$3.59
250ST2464	1/4"	1"	3/8"	5/8"	9/16"	MAG. IMPACT SOCKET	\$3.59
250ST2864	1/4"	1"	7/16"	11/16"	5/8"	MAG. IMPACT SOCKET	\$3.89
250ST3264	1/4"	1"	1/2"	3/4"	3/4"	MAG. IMPACT SOCKET	\$3.89

1/4" SQUARE DRIVE

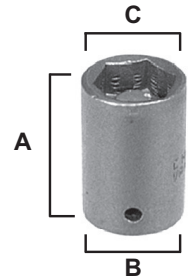

3/8" SQUARE DRIVE MAGNETIC IMPACT SOCKETS

PART NUMBER	SQUARE DRIVE	(A) LENGTH	HEX OPENING	(B) BODY	(C) NOSE	DESCRIPTION	PRICE EACH
375ST1664	3/8"	1-1/4"	1/4"	3/4"	7/16"	MAG. IMPACT SOCKET	\$3.99
375ST2064	3/8"	1-1/4"	5/16"	3/4"	1/2"	MAG. IMPACT SOCKET	\$3.99
375ST2464	3/8"	1-1/4"	3/8"	3/4"	9/16"	MAG. IMPACT SOCKET	\$3.99
375ST2864	3/8"	1-1/4"	7/16"	3/4"	5/8"	MAG. IMPACT SOCKET	\$3.99
375ST3264	3/8"	1-1/2"	1/2"	15/16"	3/4"	MAG. IMPACT SOCKET	\$4.41

3/8" SQUARE DRIVE

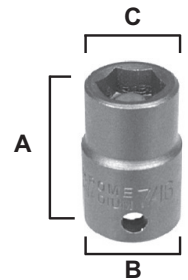

1/2" SQUARE DRIVE MAGNETIC IMPACT SOCKETS

PART NUMBER	SQUARE DRIVE	(A) LENGTH	HEX OPENING	(B) BODY	(C) NOSE	DESCRIPTION	PRICE EACH
500ST1664	1/2"	1-1/2"	1/4"	15/16"	7/16"	MAG. IMPACT SOCKET	\$5.34
500ST2064	1/2"	1-1/2"	5/16"	15/16"	1/2"	MAG. IMPACT SOCKET	\$5.34
500ST2464	1/2"	1-1/2"	3/8"	15/16"	9/16"	MAG. IMPACT SOCKET	\$5.34
500ST2864	1/2"	1-1/2"	7/16"	15/16"	5/8"	MAG. IMPACT SOCKET	\$5.34
500ST3264	1/2"	1-1/2"	1/2"	15/16"	3/4"	MAG. IMPACT SOCKET	\$5.74

1/2" SQUARE DRIVE

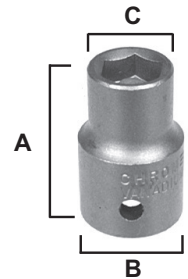

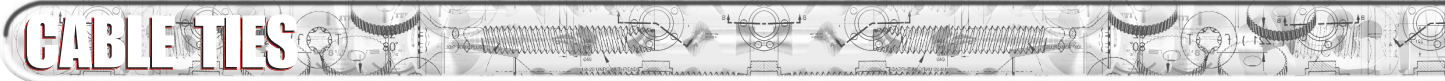

NATURAL NYLON 6.6 CABLE TIES

B U L K	PART NUMBER	LENGTH	LOOP TENSILE STRENGTH	WIDTH	BUNDLE DIAMETER	MILITARY SPECIFICATION	BULK BAG QTY.	PRICE PER 1000
	MS0016	4"	18 lbs.	3/32"	1/16" → 5/8"	MS-3367-4-9	1000	\$15.88
	MS0032	5.5"	40 lbs.	1/8"	1/16" → 1-1/4"	MS-3367-5-9	1000	\$22.52
	MS0050	8"	50 lbs.	1/8"	1/16" → 2-1/8"	MS-3367-4-9	1000	\$30.92
	MS0070	11"	50 lbs.	3/16"	1/16" → 3"	MS-3367-7-9	1000	\$61.65
	MS0108	15"	50 lbs.	3/16"	1/16" → 4"	MS-3367-2-9	500	\$79.48

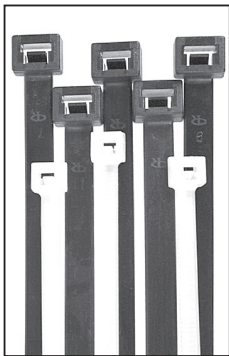

NATURAL NYLON 6.6 CABLE TIES

PEG BOARDABLE BAGS

B A G	PART NUMBER	LENGTH	LOOP TENSILE STRENGTH	WIDTH	BUNDLE DIAMETER	MILITARY SPECIFICATION	BAG QTY.	PRICE PER BAG
	804MS0016	4"	18 lbs.	3/32"	1/16" → 5/8"	MS-3367-4-9	100	\$4.18
	804MS0032	5.5"	40 lbs.	1/8"	1/16" → 1-1/4"	MS-3367-5-9	100	\$5.22
	804MS0050	8"	50 lbs.	1/8"	1/16" → 2-1/8"	MS-3367-4-9	100	\$6.32
	804MS0070	11"	50 lbs.	3/16"	1/16" → 3"	MS-3367-7-9	100	\$13.92
	804MS0108	15"	50 lbs.	3/16"	1/16" → 4"	MS-3367-2-9	100	\$19.14

EXTRA HEAVY DUTY NATURAL NYLON 6.6 CABLE TIES

B U L K	PART NUMBER	LENGTH	LOOP TENSILE STRENGTH	WIDTH	BUNDLE DIAMETER	MILITARY SPECIFICATION	BULK BAG QTY.	PRICE PER 100
	804MSXV50	8"	120 lbs.	5/16"	3/16" → 2"	-	100	\$17.69
	804MSXV70	11"	120 lbs.	5/16"	3/16" → 3"	-	100	\$19.67
	804MSXV18	15"	120 lbs.	5/16"	3/16" → 4"	-	100	\$22.74
	804MS0152	24"	175 lbs.	3/8"	3/16" → 7"	-	100	\$41.45
	804MS0225	36"	175 lbs.	3/8"	3/16" → 10"	-	100	\$48.02
	804MS0300	42"	175 lbs.	3/8"	3/16" → 12"	-	100	\$71.94

- Manufactured of 100% Nylon
- Non-Corrosive
- Specification: Type 6.6 Nylon
- Self-Extinguishing
- Natural & Weather Resistant Black Operating Temperatures From 40° F (-40° C) to 185° F (85° C).
- Recognized Under the Components Program of Underwriter Laboratories, Inc.

File # E 57800.

BLACK WEATHER RESISTANT NYLON CABLE TIES

B U L K	PART NUMBER	LENGTH	LOOP TENSILE STRENGTH	WIDTH	BUNDLE DIAMETER	MILITARY SPECIFICATION	BULK BAG QTY.	PRICE PER 1000
	BWR0016	4"	18 lbs.	3/32"	1/16" → 5/8"	MS-3367-4-0	1000	\$17.94
	BWR0032	5.5"	40 lbs.	1/8"	1/16" → 1-1/4"	MS-3367-5-0	1000	\$26.15
	BWR0050	8"	50 lbs.	1/8"	1/16" → 2-1/8"	MS-3367-4-0	1000	\$34.18
	BWR0070	11"	50 lbs.	3/16"	1/16" → 3"	MS-3367-7-0	1000	\$71.79
	BWR0108	15"	50 lbs.	3/16"	1/16" → 4"	MS-3367-2-0	500	\$110.49

BLACK WEATHER RESISTANT NYLON CABLE TIES

PEG BOARDABLE

B A G	PART NUMBER	LENGTH	LOOP TENSILE STRENGTH	WIDTH	BUNDLE DIAMETER	MILITARY SPECIFICATION	BAG QTY.	PRICE PER BAG
	BWR00SL16	4"	18 lbs.	3/32"	1/16" → 5/8"	MS-3367-4-0	100	\$5.02
	BWR00SL32	5.5"	40 lbs.	1/8"	1/16" → 1-1/4"	MS-3367-5-0	100	\$6.26
	BWR00SL50	8"	50 lbs.	1/8"	1/16" → 2-1/8"	MS-3367-4-0	100	\$7.58
	BWR00SL70	11"	50 lbs.	3/16"	1/16" → 3"	MS-3367-7-0	100	\$14.99
	BWR0SL108	15"	50 lbs.	3/16"	1/16" → 4"	MS-3367-2-0	100	\$20.69

EXTRA H.D. BLACK WEATHER RESISTANT NYLON CABLE TIES

B U L K	PART NUMBER	LENGTH	LOOP TENSILE STRENGTH	WIDTH	BUNDLE DIAMETER	MILITARY SPECIFICATION	BULK BAG QTY.	PRICE PER 100
	XBWR050	8"	120 lbs.	5/16"	3/16" → 2"	-	100	\$17.99
	XBWR070	11"	120 lbs.	5/16"	3/16" → 3"	-	100	\$20.27
	XBWR108	15"	120 lbs.	5/16"	3/16" → 4"	-	100	\$25.72
	XBWR152	24"	175 lbs.	3/8"	3/16" → 7"	-	100	\$45.15
	XBWR225	36"	175 lbs.	3/8"	3/16" → 10"	-	100	\$56.60
	XBWR300	42"	175 lbs.	3/8"	3/16" → 12"	-	100	\$85.19



MAIN OFFICE
INTERNATIONAL TOOL MANUFACTURING
71-08 51ST. AVENUE, WOODSIDE, NY 11377
(718) 446-0711 • (800) 247-5696 • FAX (718) 899-6553



INTERNATIONAL TOOL MANUFACTURING
675-E-PROGRESS CENTER AVE., LAWRENCEVILLE, GA 30043
(770) 962-5454 • (800) 229-1776 • FAX (770) 962-5869

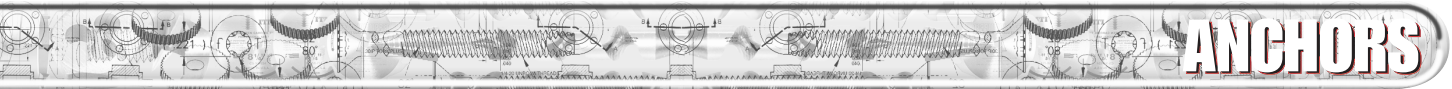

CONICAL PLASTIC ANCHORS

PART NUMBER	SIZE	SCREW SIZE	ANCHOR TYPE	COLOR	CARTON QTY.	PACKAGED	PRICE / M
803CA0004	3/16" X 3/4"	4 - 6	CONICAL	RED	60,000	BULK	\$6.99
803CAB004	3/16" X 3/4"	4 - 6	CONICAL	BLUE	60,000	BULK	\$6.99
803CA0006	3/16" X 7/8"	6 - 8	CONICAL	RED	40,000	BULK	\$6.99
803CAB006	3/16" X 7/8"	6 - 8	CONICAL	BLUE	40,000	BULK	\$6.99
803CA0008	1/4" X 1"	8 - 10	CONICAL	RED	20,000	BULK	\$9.23
803CAB008	1/4" X 1"	8 - 10	CONICAL	BLUE	20,000	BULK	\$9.23
803CA0012	5/16" X 1-1/4"	12 - 16	CONICAL	RED	12,000	BULK	\$15.61
803CAB012	5/16" X 1-1/4"	12 - 16	CONICAL	BLUE	12,000	BULK	\$15.61

**B
U
L
K**



**MADE
IN THE
USA**

Installation:

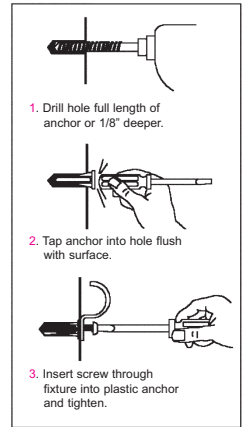

CONICAL PLASTIC ANCHORS

PART NUMBER	SIZE	SCREW SIZE	ANCHOR TYPE	COLOR	BAG QTY.	PACKAGED	PRICE PER BAG
806CA0006	3/16" X 7/8"	6 - 8	CONICAL	RED	1,000	BAG	\$8.87
806CAB006	3/16" X 7/8"	6 - 8	CONICAL	BLUE	1,000	BAG	\$8.87
806CA0008	1/4" X 1"	8 - 10	CONICAL	RED	500	BAG	\$7.55
806CAB008	1/4" X 1"	8 - 10	CONICAL	BLUE	500	BAG	\$7.55
806CA0012	5/16" X 1-1/4"	12 - 16	CONICAL	RED	500	BAG	\$12.75
806CAB012	5/16" X 1-1/4"	12 - 16	CONICAL	BLUE	500	BAG	\$12.75

**B
A
G**

Conical Plastic Anchors can be used in solid or hollow wall with either wood or sheet metal screws.



BAG

BOXED RIBBED/CONICAL PLASTIC ANCHORS

PART NUMBER	SIZE	SCREW SIZE	ANCHOR TYPE	COLOR	BAG QTY.	PACKAGED	PRICE PER BOX
802RB0006	3/16" X 7/8"	6 - 8	RIBBED	RED ONLY	100	BOX	\$1.91
802RB0008	1/4" X 1"	8 - 12	RIBBED	RED ONLY	100	BOX	\$2.71
802RB0012	5/16" X 1-1/4"	12 - 16	RIBBED	RED ONLY	100	BOX	\$5.21
802CA0006	3/16" X 7/8"	6 - 8	CONICAL	BLUE ONLY	100	BOX	\$1.91
802CA0008	1/4" X 1"	8 - 12	CONICAL	BLUE ONLY	100	BOX	\$2.71
802CA0012	5/16" X 1-1/4"	12 - 16	CONICAL	BLUE ONLY	100	BOX	\$5.21

**B
O
X**



BOX

MAIN OFFICE
INTERNATIONAL TOOL MANUFACTURING
 71-08 51ST. AVENUE, WOODSIDE, NY 11377
 (718) 446-0711 • (800) 247-5696 • FAX (718) 899-6553



INTERNATIONAL TOOL MANUFACTURING
 675-E-PROGRESS CENTER AVE., LAWRENCEVILLE, GA 30043
 (770) 962-5454 • (800) 229-1776 • FAX (770) 962-5869

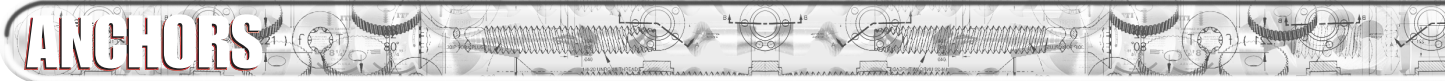

**MADE
 IN THE
 USA**



- Internal Ribs for Better Centering of Screw.
- Locking Lugs Against Pull & Twist.
- Special Exterior Design Prevents Fall Out in Overhead Holes.
- Deep Teeth give Maximum Anchoring in Concrete, and Bite Deeply in Drywall or Wood.
- Unique Expansion Capacity in Soft Material.

Ribbed Plastic Anchors can be used in solid or hollow wall with either wood or sheet metal screws.



BAG

RIBBED PLASTIC ANCHORS - WITH COLLAR

	PART NUMBER	SIZE	SCREW SIZE	ANCHOR TYPE	COLOR	CARTON QTY.	PACKAGED	PRICE / M
B U L K	800RB0006	3/16" X 7/8"	6 - 8	RIBBED	RED	40,000	BULK	\$7.51
	800RBG006	3/16" X 7/8"	6 - 8	RIBBED	GRAY	40,000	BULK	\$7.51
	800RBW006	3/16" X 7/8"	6 - 8	RIBBED	WHITE	40,000	BULK	\$7.51
	800RBY006	3/16" X 7/8"	6 - 8	RIBBED	YELLOW	40,000	BULK	\$7.51
B U L K	800RB0008	1/4" X 1"	8 - 12	RIBBED	RED	20,000	BULK	\$9.98
	800RBG008	1/4" X 1"	8 - 12	RIBBED	GRAY	20,000	BULK	\$9.98
	800RBW008	1/4" X 1"	8 - 12	RIBBED	WHITE	20,000	BULK	\$9.98
	800RBX008	1/4" X 1"	8 - 12	RIBBED	GREEN	20,000	BULK	\$9.98
	800RBB008	1/4" X 1"	8 - 12	RIBBED	BLUE	20,000	BULK	\$9.98
B U L K	800RB0014	5/16" X 1-1/4"	12 - 16	RIBBED	RED	12,000	BULK	\$17.21
	800RBG014	5/16" X 1-1/4"	12 - 16	RIBBED	GRAY	12,000	BULK	\$17.21
	800RBW014	5/16" X 1-1/4"	12 - 16	RIBBED	WHITE	12,000	BULK	\$17.21
	800RBN014	5/16" X 1-1/4"	12 - 16	RIBBED	GREEN	12,000	BULK	\$17.21

RIBBED PLASTIC ANCHORS - WITH COLLAR

	PART NUMBER	SIZE	SCREW SIZE	ANCHOR TYPE	COLOR	BAG QTY.	PACKAGED	PRICE PER BAG
B A G	805RBR006	3/16" X 7/8"	6 - 8	RIBBED	RED	1,000	BAG	\$10.41
	805RBG006	3/16" X 7/8"	6 - 8	RIBBED	GRAY	1,000	BAG	\$10.41
	805RBW006	3/16" X 7/8"	6 - 8	RIBBED	WHITE	1,000	BAG	\$10.41
	805RBY006	3/16" X 7/8"	6 - 8	RIBBED	YELLOW	1,000	BAG	\$10.41
B A G	805RBR008	1/4" X 1"	8 - 12	RIBBED	RED	500	BAG	\$8.49
	805RBG008	1/4" X 1"	8 - 12	RIBBED	GRAY	500	BAG	\$8.49
	805RBW008	1/4" X 1"	8 - 12	RIBBED	WHITE	500	BAG	\$8.49
	805RBB008	1/4" X 1"	8 - 12	RIBBED	BLUE	500	BAG	\$8.49
B A G	805RBR010	5/16" X 1-1/4"	12 - 16	RIBBED	RED	500	BAG	\$16.49
	805RBG010	5/16" X 1-1/4"	12 - 16	RIBBED	GRAY	500	BAG	\$16.49
	805RBW010	5/16" X 1-1/4"	12 - 16	RIBBED	WHITE	500	BAG	\$16.49
	805RBN010	5/16" X 1-1/4"	12 - 16	RIBBED	GREEN	500	BAG	\$16.49

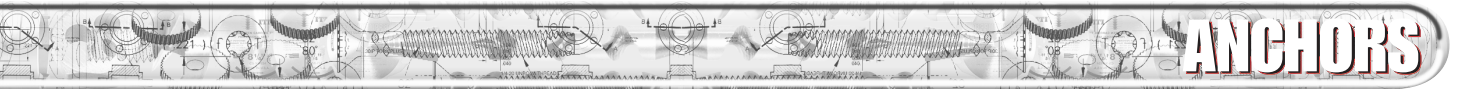

SUPER RIBBED PLASTIC ANCHORS

PART NUMBER	SIZE	SCREW SIZE	ANCHOR TYPE	COLOR	CARTON QTY.	PACKAGED	PRICE / M
SA316Y	3/16" X 7/8"	6 - 8	<i>SUPER RIBBED</i>	YELLOW	40,000	BULK	\$11.91
SA014Y	1/4" X 1-1/4"	8 - 12	<i>SUPER RIBBED</i>	YELLOW	18,000	BULK	\$15.99
SA516Y	5/16" X 1-1/2"	12 - 16	<i>SUPER RIBBED</i>	YELLOW	10,000	BULK	\$27.80

**B
U
L
K**

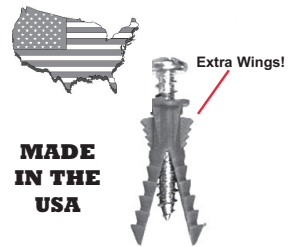

SUPER RIBBED PLASTIC ANCHORS

PART NUMBER	SIZE	SCREW SIZE	ANCHOR TYPE	COLOR	BAG QTY.	PACKAGED	PRICE PER BAG
BASA316	3/16" X 7/8"	6 - 8	<i>SUPER RIBBED</i>	YELLOW	1,000	BAG	\$14.20
BASA014	1/4" X 1-1/4"	8 - 12	<i>SUPER RIBBED</i>	YELLOW	500	BAG	\$11.40
BASA516	5/16" X 1-1/2"	12 - 16	<i>SUPER RIBBED</i>	YELLOW	500	BAG	\$17.25

**B
A
G**

SUPER RIBBED PLASTIC ANCHORS

PART NUMBER	SIZE	SCREW SIZE	ANCHOR TYPE	COLOR	BAG QTY.	PACKAGED	PRICE PER BAG
BASA316R	3/16" X 7/8"	6 - 8	<i>SUPER RIBBED</i>	YELLOW	100	BOX	\$2.41
BASA014R	1/4" X 1-1/4"	8 - 12	<i>SUPER RIBBED</i>	YELLOW	100	BOX	\$3.10
BASA516R	5/16" X 1-1/2"	12 - 16	<i>SUPER RIBBED</i>	YELLOW	100	BOX	\$5.98

**B
O
X**

- Bright Yellow.
- Extra Wings to Grip Directly to Wall.
- Locking Lugs Against Pull & Twist.
- Special Exterior Design Prevents Fall Out in Overhead Holes.
- Deep Teeth give Maximum Anchoring in Concrete, and Bite Deeply in Drywall or Wood.
- Unique Expansion Capacity in Soft Material.

NYLON ZAP-IN ANCHORS

PART NUMBER	LENGTH	DESCRIPTION	BOX QTY.	PACKAGED	PRICE / C
EZN1212	1-3/4"	ZAP IN NYLON ANCHOR	100	BOX	\$19.90
EZN1212B	1-3/4"	ZAP IN NYLON ANCHOR	5,000	BULK	\$18.90
EZN1012	1-5/16"	ZAP IN JR. NYLON ANCHOR	100	BOX	\$14.50
EZN1012B	1-5/16"	ZAP IN JR. NYLON ANCHOR	5,000	BULK	\$13.90

ZINC ZAP-IN ANCHORS

PART NUMBER	LENGTH	DESCRIPTION	BOX QTY.	PACKAGED	PRICE / C
EZZ1212	1-3/4"	ZAP IN ZINC ANCHOR	100	BOX	\$21.98
EZZ1212B	1-3/4"	ZAP IN ZINC ANCHOR	5,000	BULK	\$20.98
EZZ1012	1-5/16"	ZAP IN JR. ZINC ANCHOR	100	BOX	\$18.20
EZZ1012B	1-5/16"	ZAP IN JR. ZINC ANCHOR	5,000	BULK	\$16.90

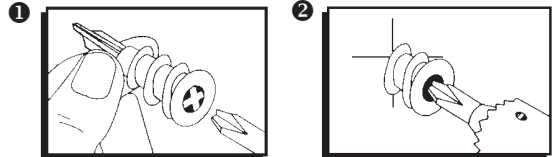

Insert either #2 or #3 Phillips Driver bit into the recess of Zap-In anchor head. Use screw driver or screw gun.

Push Zap-In anchor into surface of wallboard until the two cutting blades penetrate the surface. Using gentle forward pressure, rotate anchor until collar sets flush to surface of wall.

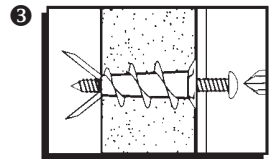

Put fixture in place, insert screw & tighten until secure.

- Use #8 Screws, minimum 3/4" long.
- Wall board should be 3/8" - 1" thick.

MADE IN USA

MAIN OFFICE
INTERNATIONAL TOOL MANUFACTURING
 71-08 51ST. AVENUE, WOODSIDE, NY 11377
 (718) 446-0711 • (800) 247-5696 • FAX (718) 899-6553



INTERNATIONAL TOOL MANUFACTURING
 675-E-PROGRESS CENTER AVE., LAWRENCEVILLE, GA 30043
 (770) 962-5454 • (800) 229-1776 • FAX (770) 962-5869

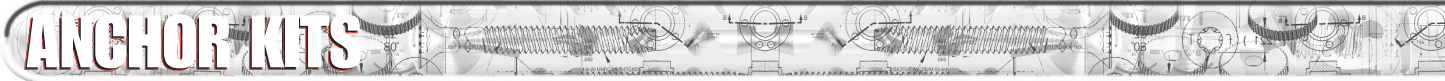

**KITS
 MADE
 IN THE
 USA**

- High Quality Impact Resistant Clear Box with Separations.
- 4" Long Slow Spiral Gold Head Black Masonry Bit Matching Anchor Sizes.
- High Quality Screws Match Anchor Sizes.
- Same High Quality American Made Anchors as on Pages 105-107.



RIBBED ANCHOR - RED



CONICAL ANCHOR - BLUE



SUPER ANCHOR - YELLOW



ZAP-IN ANCHOR



**HEX HEAD
 SCREW**



**COMBO
 HEAD
 SCREW**

PART #
807AK006
 100 pcs. - 3/16" Ribbed Anchors
 100 pcs. - #8 Combo Screws
 1 pc. - 3/16" Slow Spiral Masonry
PRICE EACH KIT \$6.95

PART #
807AX007
 100 pcs. - 1/4" Ribbed Anchors
 100 pcs. - #10 HEX Screws
 1 pc. - 1/4" Slow Spiral Masonry
PRICE EACH KIT \$8.62



PART #
807AK0016
 100 pcs. - 1/4" Ribbed Anchors
 100 pcs. - #10 Combo Screws
 1 pc. - 1/4" Slow Spiral Masonry
PRICE EACH KIT \$7.92

PART #
807AK0009
 50 pcs. - 5/16" Ribbed Anchors
 50 pcs. - #12 Combo Screws
 1 pc. - 5/16" Slow Spiral Masonry
PRICE EACH KIT \$10.51



PART #
807AK0010
 100 pcs. - 3/16" Conical Anchors
 100 pcs. - #8 Combo Screws
 1 pc. - 3/16" Slow Spiral Masonry
PRICE EACH KIT \$6.95

PART #
807AK0011
 100 pcs. - 1/4" Conical Anchors
 100 pcs. - #10 Combo Screws
 1 pc. - 1/4" Slow Spiral Masonry
PRICE EACH KIT \$7.40

PART #
807AK0012
 100 pcs. - 1/4" Conical Anchors
 100 pcs. - #10 HEX Screws
 1 pc. - 1/4" Slow Spiral Masonry
PRICE EACH KIT \$7.96

PART #
807AK0013
 50 pcs. - 5/16" Conical Anchors
 50 pcs. - #12 Combo Screws
 1 pc. - 5/16" Slow Spiral Masonry
PRICE EACH KIT \$10.51



PART #
SUPRAK006
 100 pcs. - 3/16" SUPER Anchors
 100 pcs. - #8 Combo Screws
 1 pc. - 3/16" Slow Spiral Masonry
PRICE EACH KIT \$7.73

PART #
SUPRAK007
 100 pcs. - 1/4" SUPER Anchors
 100 pcs. - #10 x 1-1/4" HEX Screws
 1 pc. - 1/4" Slow Spiral Masonry
PRICE EACH KIT \$8.20

PART #
SUPRAK008
 100 pcs. - 1/4" SUPER Anchors
 100 pcs. - #10 x 1-1/4" Combo Screws
 1 pc. - 1/4" Slow Spiral Masonry
PRICE EACH KIT \$7.82

PART #
SUPRAK009
 50 pcs. - 5/16" SUPER Anchors
 50 pcs. - #12 x 1-1/2" Combo Screws
 1 pc. - 5/16" Slow Spiral Masonry
PRICE EACH KIT \$10.52

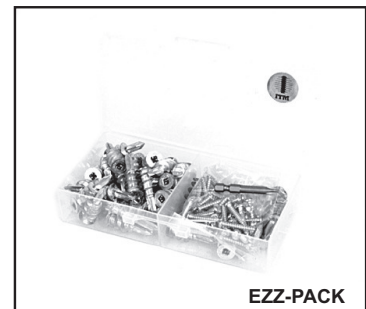

PART #
EZN-PACK
 50 pcs. - Nylon Zap-In
 50 pcs. - #8 x 1" Combo Screws
 1 pc. - #2 X 2" Phillips Bit
PRICE EACH KIT \$19.10

PART #
EZZ-PACK
 50 pcs. - Zinc Zap-In
 50 pcs. - #8 x 1" Combo Screws
 1 pc. - #2 X 2" Phillips Bit
PRICE EACH KIT \$19.40

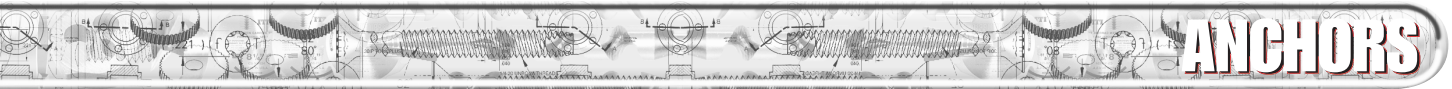

**SPLIT SHANK HAMMER DRIVE ANCHORS
 ROUND HEAD**

PART NUMBER	SIZE	DRILL SIZE	WEIGHT / C	MINIMUM EMBEDMENT	BOX QTY.	PRICE / C
RDA14125	1/4" X 1-1/4"	1/4"	2.20 lbs.	1-1/8"	100	\$28.29
RDA14150	1/4" X 1-1/2"	1/4"	2.36 lbs.	1-1/8"	100	\$28.29
RDA14200	1/4" X 2"	1/4"	2.50 lbs.	1-1/8"	100	\$32.21
RDA14225	1/4" X 2-1/2"	1/4"	3.60 lbs.	1-1/8"	100	\$35.38
RDA38225	3/8" X 2-1/2"	3/8"	10.00 lbs.	1-1/8"	100	\$47.37

Meets or exceeds GSA Specification FF-S-325, Group IV.

**SPLIT SHANK HAMMER DRIVE ANCHORS
 FLAT HEAD**

PART NUMBER	SIZE	DRILL SIZE	WEIGHT / C	MINIMUM EMBEDMENT	BOX QTY.	PRICE / C
FDA14150	1/4" X 1-1/2"	1/4"	2.36 lbs.	1-1/8"	100	\$28.29
FDA14200	1/4" X 2"	1/4"	2.50 lbs.	1-1/8"	100	\$32.21
FDA14250	1/4" X 2-1/2"	1/4"	3.60 lbs.	1-1/8"	100	\$35.38
FDA14300	1/4" X 3"	1/4"	4.50 lbs.	1-1/8"	100	\$38.51
FDA14350	1/4" X 3-1/2"	1/4"	5.40 lbs.	1-1/8"	100	\$42.43
FDA14400	1/4" X 4"	1/4"	6.30 lbs.	1-1/8"	100	\$46.38

Meets or exceeds GSA Specification FF-S-325, Group IV.

LAG SHIELD ANCHORS - SHORT

PART NUMBER	BOLT SIZE	BOLT LENGTH	DRILL SIZE	WEIGHT / C	BOX QTY.	PRICE / C
LSS1664	1/4"	1"	1/2"	2.90 lbs.	50	\$29.48
LSS2064	5/16"	1-1/4"	1/2"	2.90 lbs.	50	\$31.86
LSS2464	3/8"	1-3/4"	5/8"	6.80 lbs.	50	\$47.59
LSS3264	1/2"	2"	3/4"	9.70 lbs.	25	\$79.20

Meets or exceeds GSA Specification FF-S-325, Group II, Type 1, Class 1 & 2.

LAG SHIELD ANCHORS - LONG

PART NUMBER	BOLT SIZE	BOLT LENGTH	DRILL SIZE	WEIGHT / C	BOX QTY.	PRICE / C
LSL1664	1/4"	1-1/2"	1/2"	4.30 lbs.	50	\$32.08
LSL2064	5/16"	1-3/4"	1/2"	4.00 lbs.	50	\$37.73
LSL2464	3/8"	2-1/2"	5/8"	9.70 lbs.	50	\$61.56
LSL3264	1/2"	3"	3/4"	14.80 lbs.	25	\$90.84

Meets or exceeds GSA Specification FF-S-325, Group II, Type 1, Class 1 & 2.

NOTE: All anchor prices subject to change.



Suitable For:
 • Concrete
 • Stone
 • Solid Brick

EASY TO INSTALL

No Screws Necessary. Just Drill 1/4" Hole and Hammer In the Anchor.



Suitable For:
 • Concrete
 • Stone
 • Solid Brick



SHORT - FOR HARD MATERIALS.

- ZINC ALLOY.
- RUST PROOF.
- USE WITH LAG BOLT.
- INDUSTRIAL QUALITY.



LONG - FOR SOFT MATERIALS.

Suitable For:
 • Concrete
 • Stone
 • Solid Brick
 • Any Other Type of Masonry.

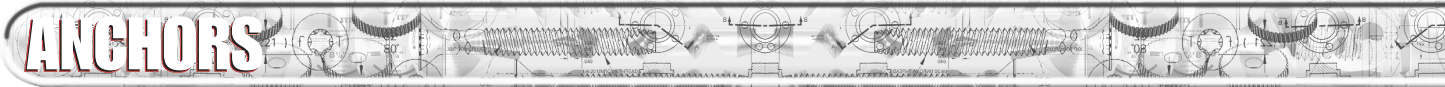

STEP BY STEP
INSTALLATION
INSTRUCTIONS

- Drill Hole at Indicated Drill Size & Bolt Length.
- Insert Expansion Shield with Threaded End Bottom First. Shield Should be Flush at Surface, or Slightly above Surface Plane.
- Insert Screw or Bolt and Tighten.
- Length of screw should equal Bolt Length plus Thickness of Fixture Used.

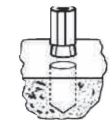
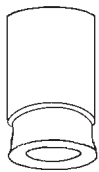

Drill Hole in floor or wall to proper size and depth. Insert anchor in hole tapered end first.

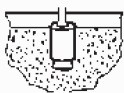

Use hammer and setting tool to drive anchor. This forces the lead sleeve into wall crevices and packs it around the nut.



Fasten work to anchor with machine screw.

SINGLE EXPANSION SHIELDS

PART NUMBER	BOLT SIZE	BOLT LENGTH	DRILL SIZE	WEIGHT / C	BOX QTY.	PRICE / C
SES1664	1/4" - 20	1-5/16"	1/2"	3.60	50	\$56.95
SES2064	5/16" - 18	1-1/2"	5/8"	8.40	50	\$83.76
SES2464	3/8" - 16	1-1/2"	3/4"	12.30	50	\$93.13
SES3264	1/2" - 13	2"	7/8"	19.10	25	\$177.12
SES4064	5/8" - 11	2-1/4"	1"	26.50	20	\$212.28
SES4864	3/4" - 10	2-7/8"	1-1/4"	43.00	10	\$428.54

Meets or exceeds GSA Specification FF-S-325, Group II, Type 2, Class 2, Style 1.

DOUBLE EXPANSION SHIELDS

PART NUMBER	BOLT SIZE	BOLT LENGTH	DRILL SIZE	WEIGHT / C	BOX QTY.	PRICE / C
DES1664	1/4" - 20	1"	1/2"	3.90	50	\$59.65
DES2064	5/16" - 18	1-1/4"	5/8"	6.90	50	\$87.70
DES2464	3/8" - 16	1-1/2"	3/4"	12.40	50	\$108.72
DES3264	1/2" - 13	2"	7/8"	19.20	25	\$177.30
DES4064	5/8" - 11	2-1/4"	1"	26.50	20	\$213.26
DES4864	3/4" - 10	2-7/8"	1-1/4"	59.50	10	\$468.25

Meets or exceeds GSA Specification FF-S-325, Group II, Type 2, Class 2, Style 2.

MACHINE SCREW ANCHORS

PART NUMBER	BOLT SIZE	BOLT LENGTH	DRILL SIZE	WEIGHT / C	BOX QTY.	PRICE / C
MSA1024	10 - 24	3/4"	3/8"	2.10	100	\$20.81
MSA1664	1/4" - 20	15/16"	1/2"	4.50	100	\$27.90
MSA2464	3/8" - 16	1-3/8"	3/4"	14.00	50	\$76.68
MSA3264	1/2" - 13	1-9/16"	7/8"	19.00	50	\$123.84

Meets or exceeds GSA Specification FF-S-325, Group II, Type 2, Class 1.

MACHINE SCREW ANCHOR SETTING TOOL

PART NUMBER	DESCRIPTION	QTY	PRICE
ST1024	SETTING TOOL FOR 10 - 24	1	\$2.16
ST1420	SETTING TOOL FOR 1/4" - 20	1	\$2.38
ST3816	SETTING TOOL FOR 3/8" - 16	1	\$3.17
ST1213	SETTING TOOL FOR 1/2" - 13	1	\$3.72

NOTE: All anchor prices subject to change.

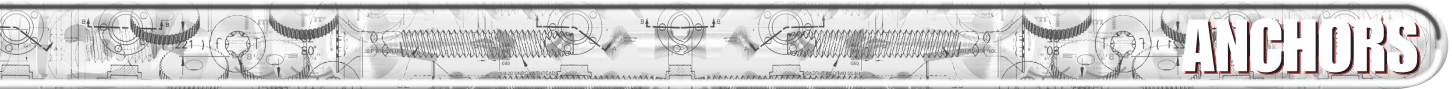

**NYLON ANCHORS WITH MOUNTED NAIL
 ROUND HEAD**

PART NUMBER	SIZE	HEAD TYPE	DRILL SIZE	BOX QTY.	PRICE / C
809NAOR61	3/16" X 1"	ROUND	3/16"	100	\$6.29
809NAOR81	1/4" X 1"	ROUND	1/4"	100	\$6.41
809NAOR85	1/4" X 1-1/2"	ROUND	1/4"	50	\$9.77
809NAOR82	1/4" X 2"	ROUND	1/4"	50	\$15.05

Meets or exceeds GSA Specification FF-S-325, Group V, Type 2, Class 4.

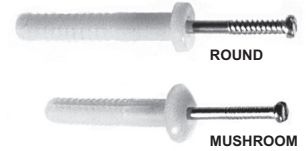

- Nylon.
- Clear Color.
- Mounted Nail.
- Screw Type Nail.

Installation for both NYLON & ZINC Anchors:

**NYLON ANCHORS WITH MOUNTED NAIL
 MUSHROOM HEAD**

PART NUMBER	SIZE	HEAD TYPE	DRILL SIZE	BOX QTY.	PRICE / C
809NAOM61	3/16" X 1"	MUSHROOM	3/16"	100	\$6.29
809NAOM65	3/16" X 1-1/2"	MUSHROOM	3/16"	100	\$9.77
809NAOM80	1/4" X 3/4"	MUSHROOM	1/4"	100	\$6.29
809NAOM81	1/4" X 1"	MUSHROOM	1/4"	100	\$6.41
809NAOM85	1/4" X 1-1/2"	MUSHROOM	1/4"	100	\$9.77
809NAOM82	1/4" X 2"	MUSHROOM	1/4"	50	\$15.05
809NAOM83	1/4" X 3"	MUSHROOM	1/4"	50	\$17.76
809NAOM84	1/4" X 4"	MUSHROOM	1/4"	50	\$22.03

Meets or exceeds GSA Specification FF-S-325, Group V, Type 2, Class 4.

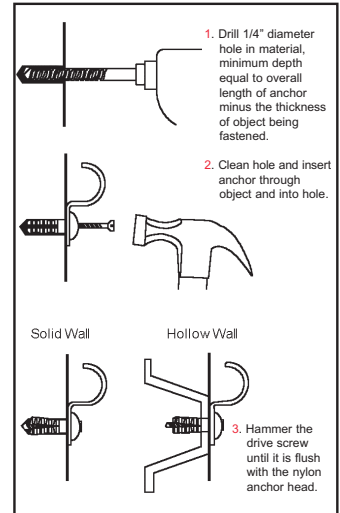

These versatile anchors can be used in hollow and solid masonry, plaster, brick, stone, as well as in sheet metal.

**ZINC HAMMER DRIVE ANCHORS
 MUSHROOM HEAD**

PART NUMBER	SIZE	HEAD TYPE	DRILL SIZE	BOX QTY.	PRICE / C
810HD14340	1/4" X 3/4"	MUSHROOM	1/4"	100	\$16.73
810HD14010	1/4" X 1"	MUSHROOM	1/4"	100	\$17.05
810HD14114	1/4" X 1-1/4"	MUSHROOM	1/4"	100	\$18.51
810HD14112	1/4" X 1-1/2"	MUSHROOM	1/4"	100	\$21.35
810HD14200	1/4" X 2"	MUSHROOM	1/4"	100	\$28.31

Meets or exceeds GSA Specification FF-S-325, Group V, Type 2, Class 3.



NOTE: All anchor prices subject to change.

MAIN OFFICE
INTERNATIONAL TOOL MANUFACTURING
71-08 51ST. AVENUE, WOODSIDE, NY 11377
(718) 446-0711 • (800) 247-5696 • FAX (718) 899-6553



INTERNATIONAL TOOL MANUFACTURING
675-E-PROGRESS CENTER AVE., LAWRENCEVILLE, GA 30043
(770) 962-5454 • (800) 229-1776 • FAX (770) 962-5869

ACCESSORIES



PART NUMBER	DESCRIPTION	PRICE EACH
GOG001	SAFETY GOGGLES INDIVIDUALLY PACKED	\$3.06



MSK55	NON-TOXIC DUST MASK SINGLE STRAP - 5 Pack	\$1.47 per pack
MAS001	NON-TOXIC DUST MASK SINGLE STRAP - 50/ BOX	\$13.25 per box
MAS002	NON-TOXIC DUST MASK DOUBLE STRAP - 50/ BOX	\$14.58 per box

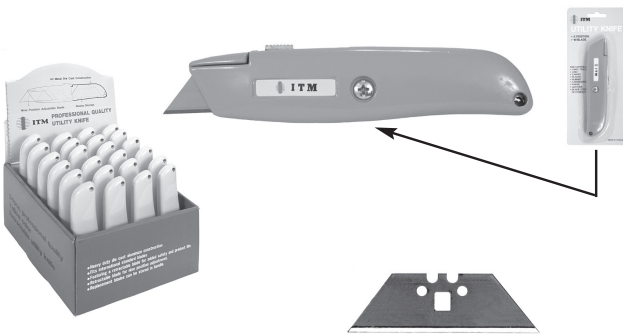

UTK001	UTILITY KNIFE - CARDED RETRACTABLE BLADE YELLOW - 9 POSITIONS	\$5.69
UTK001-B	UTILITY KNIVES - (24/BOX) RETRACTABLE BLADE YELLOW - 9 POSITIONS	\$123.75
HDB9005	5 REPLACEMENT BLADES HEAVY DUTY - 5 / Card	\$1.56
HDB9100	100 REPLACEMENT BLADES HEAVY DUTY - 20 Packs Of 5	\$20.76



FK010	FIXED BLADE TRIMMING KNIFE INDIVIDUALLY CARDED	\$4.91
-------	--	--------

MAIN OFFICE
INTERNATIONAL TOOL MANUFACTURING
 71-08 51ST. AVENUE, WOODSIDE, NY 11377
 (718) 446-0711 • (800) 247-5696 • FAX (718) 899-6553



INTERNATIONAL TOOL MANUFACTURING
 675-E-PROGRESS CENTER AVE., LAWRENCEVILLE, GA 30043
 (770) 962-5454 • (800) 229-1776 • FAX (770) 962-5869

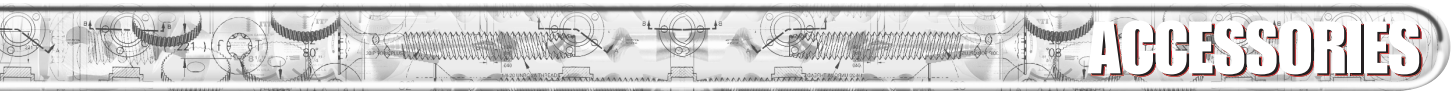

Free Counter Display With Every Order!

- RED
- YELLOW
- GREEN

3 Blade Positions.

Smooth Ergonomic Design.



HEAVY DUTY

Extra Blade Inside Compartment.

Pull Out Mechanism For Quick Blade Change.

PART NUMBER	DESCRIPTION	PRICE EACH
UTK0002	QUICK RELEASE UTILITY KNIFE (12/BOX) WITH EXTRA BLADE IN EACH KNIFE.	\$11.79

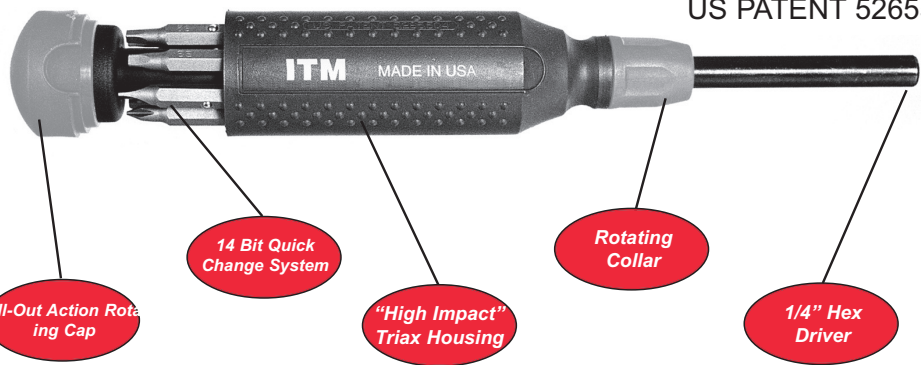

US PATENT 5265504

Full-Out Action Rotating Cap

14 Bit Quick Change System

"High Impact" Triax Housing

Rotating Collar

1/4" Hex Driver



FREE DISPLAY!!!
 WITH FIRST TIME PURCHASE OF 20 DRIVERS.
\$25 VALUE.

15in1
Screwdriver
MEGAPRO™

MADE IN USA

PART NUMBER	DESCRIPTION	PRICE EACH
MEGAPRO151	15-IN-1 MEGAPRO SCREW DRIVER #0 - #3 PHILLIPS #10 - #15 STAR #1 - #2 PHILLIPS #20 - #25 STAR #0 - #3 SQUARE #4 - #6 SLOTTED #1 - #2 SQUARE	\$36.50

SEE PAGE 101 FOR REPLACEMENT BITS.



EPS

Engineered Products & Services

Call 800-247-5696



From Concept ①

... to Production ②

... to Delivered Product ③

... in 90 Days.

www.itmeps.com

①

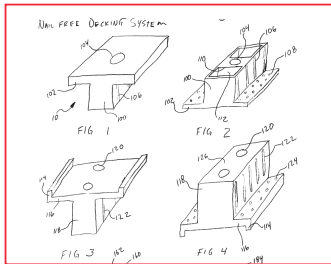

②

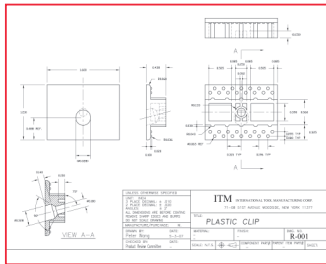

③



- Nearly 30 years of manufacturing experience.
- State-of-the-art ISO 9000 certified factories in Asia, Europe, and USA.
- Two USA distribution points.

Possibilities.

Expertise.



International Tool Manufacturing

71-08 51st Avenue
Woodside, NY 11377
Tel: 800-247-5696
Fax: 718-899-6553



675-E-Progress Ctr. Avenue
Lawrenceville, GA 30043
Tel: 800-229-1776
Fax: 770-962-5869



Engineered Products & Services

Call 800-247-5696

Need a special tool or part?

We can make it.

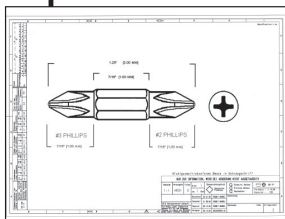
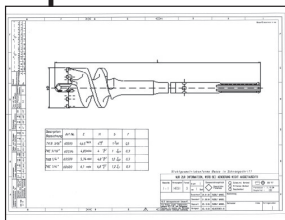
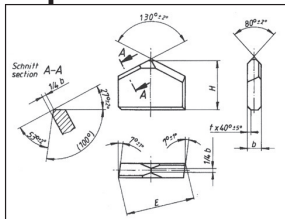
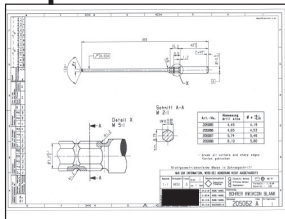
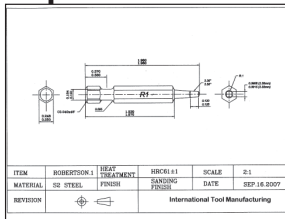
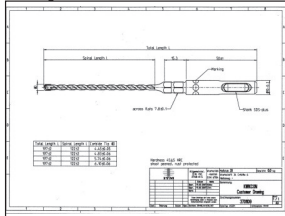

SPECIALIZATION

- Drilling Tools
- Hand Tools
- Drivers
- Fasteners
- Cutting Tools
- Components

CAPABILITIES

- Plating / Coatings
- Packaging Design & Production
- Kits / Merchandising
- Private Branding
- Barcoding
- Print Ready Digital Photo

MATERIALS

- HSS
- S2 Modified Steel
- Stainless & PH Steel
- Chrome Vanadium
- Carbon & Alloy Steel
- Carbides
- Nylons
- PP / PVC

VALUE ADDED SERVICES

- Inventory Management
- Auto-Stock Replenishment
- Reduced Procurement Costs
- Design / R&D
- Quality Control
- Educational / Training
- Compliance & Material Cert.
- Warehousing
- Drop Ship Programs

... new possibilities brought to you by



www.itmeps.com
International Tool Manufacturing

Orkan™

Precision Diamond Drill Bits

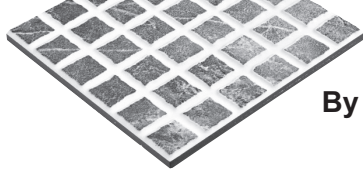

- Individually Packaged
- Barcoded
- Drilling with Water Strongly Recommended



1. Place the raised sintered edge of the bit at a 45 degree angle to the tile. Start drilling to create a half circle.

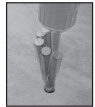

2. Continue drilling and raise the bit to 90 degrees to complete the hole in the tile. Use a swinging motion facilitate drilling.

3. Ejector slot clears the plug during repeated drilling operations.

- Glass
- Glaze
- Sanstone
- Sandware
- Terracotta
- Marble
- Tiles (up to 5th Class)
- Porcelain
- Quarry
- Terrazzo
- Agglomerate
- Cement
- Granite



Made In England.

DIAMOND GRIT

SERIES ZTD

WET DRILL

PART NUMBER	SIZE	SUGGESTED RPM's	PRICE EACH
ZTD-5	3/16"	1500-2000	\$30.00
ZTD-6	1/4"	2000-2500	\$32.22
ZTD-7	9/32"	2000-2500	\$32.22
ZTD-8	5/16"	2000-2500	\$34.44
ZTD-10	3/8"	2000-2500	\$35.56
ZTD-13	1/2"	2000-2500	\$38.89
ZTD-16	5/8"	1500-2000	\$47.78
ZTD-19	3/4"	1500-2000	\$47.78
ZTD-25	1"	1500-2000	\$66.67
ZTD-30	1-1/4"	1000-1500	\$80.00
ZTD-35	1-3/8"	1000-1500	\$82.22



3/8" HEX SHANKS

Penetrator Technology

Made In France.

DIAMOND SEGMENTED

SERIES CPD

WET / DRY DRILL

PART NUMBER	SIZE	WET RPM's	DRY RPM'S	PRICE EACH
CPD-6	1/4"	< 3000	>11,000	\$46.69
CPD-7	9/32"	< 3000	>11,000	\$46.69
CPD-8	5/16"	< 3000	>11,000	\$46.69
CPD-10	3/8"	< 3000	>11,000	\$47.67
CPD-13	1/2"	< 3000	>11,000	\$60.44
CPD-25	1"	< 3000	>11,000	\$75.17



Use with Angle Grinders or 1/2" Drills.

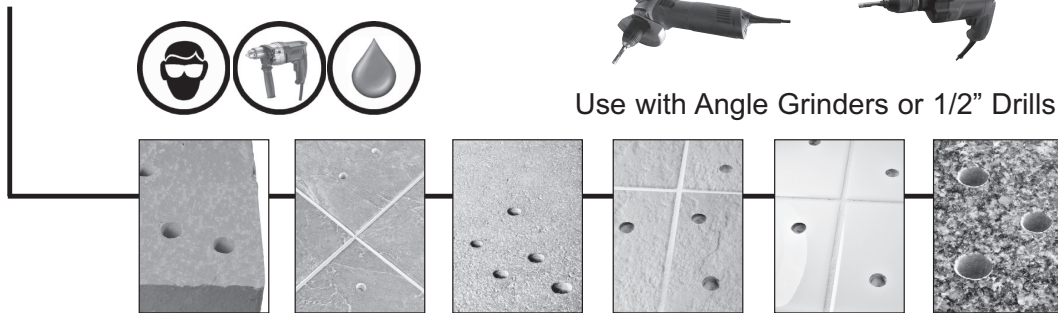

MAIN OFFICE
INTERNATIONAL TOOL MANUFACTURING
 71-08 51ST. AVENUE, WOODSIDE, NY 11377
 (718) 446-0711 • (800) 247-5696 • FAX (718) 899-6553



INTERNATIONAL TOOL MANUFACTURING
 675-E-PROGRESS CENTER AVE., LAWRENCEVILLE, GA 30043
 (770) 962-5454 • (800) 229-1776 • FAX (770) 962-5869

LAG SHIELDS

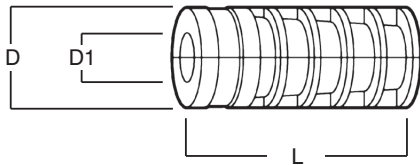

	1/4"S	5/16"S	3/8"S	1/2"S	1/4"L	5/16"L	3/8"L	1/2"L
HEAD DIAMETER (D)	1/2"	1/2"	5/8"	3/4"	1/2"	1/2"	5/8"	3/4"
INNER HOLE DIA. (D1)	1/4"	5/16"	3/8"	1/2"	1/4"	5/16"	3/8"	1/2"
OVERALL LENGTH (L)	1"	1-3/16"	1-3/4"	1-15/16"	1-1/2"	1-3/4"	2-1/2"	2-7/8"

SINGLE EXPANSION SHIELDS

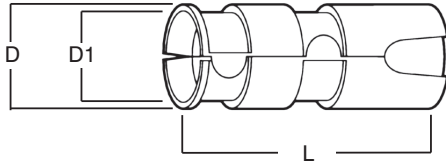

	1/4-20	5/16-18	3/8-16	1/2-13	5/8-11	3/4-10
OUTSIDE DIAMETER (D)	1/2"	5/8"	3/4"	7/8"	1"	1-1/4"
NUT THREADING SIZE (D1)	1/4-20	5/16-18	3/8-16	1/2-13	5/8-11	3/4-10
LENGTH (L)	1-5/16"	1-1/2"	1-1/2"	2-1/16"	2-5/8"	3-15/16"

DOUBLE EXPANSION SHIELDS

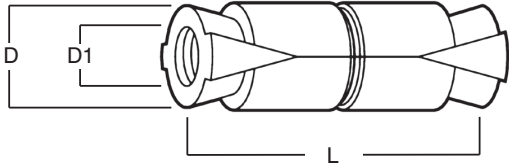

	1/4-20	5/16-18	3/8-16	1/2-13	5/8-11	3/4-10
OUTSIDE DIAMETER (D)	1/2"	5/8"	3/4"	7/8"	1"	1-1/4"
NUT THREADING SIZE (D1)	1/4-20	5/16-18	3/8-16	1/2-13	5/8-11	3/4-10
LENGTH (L)	1-5/16"	1-1/2"	2"	2-1/2"	2-5/8"	3-15/16"

⊗ For All HSS & Carbon NPT Taps.

**NPT
 TAP-DRILL CHART**



DRILL THIS SIZE HOLE			TO TAP FOR THIS BOLT OR SCREW
DECIMAL INCHES	DRILL SIZE	NEAREST FRACTION	
.3390"	Ltr. R	none	1/8-27 NPT
.4375"	7/16"	7/16"	1/4-18 NPT
.5781"	37/64"	37/64"	3/8- 8 NPT
.7031"	45/64"	45/64"	1/2-14 NPT
.9219"	59/64"	59/64"	3/4-14 NPT
1.1562"	1-5/32"	1-5/32"	1 - 11-1/2 NPT
1.5000"	1-1/2"	1-1/2"	1-1/4 - 11-1/2 NPT
1.7344"	1-47/64"	1-47/64"	1-1/2 - 11-1/2 NPT
2.2188"	2-7/32"	2-7/32"	2 - 11-1/2 NPT



Recommended Tap Drill to Use For 75% Depth of Thread.

DRILL THIS SIZE HOLE			TO TAP FOR THIS BOLT OR SCREW
DECIMAL INCHES	DRILL SIZE	NEAREST FRACTION	
.0469"	3/64"	3/64"	0-80 NF
.0595"	No. 53	none	1-64 NC
.0595"	No. 53	1/16"	1-72 NF
.0700"	No. 50	none	2-56 NC
.0700"	No. 50	none	2-64 NF
.0785"	No. 47	5/64"	3-48 NC
.0820"	No. 45	none	3-56 NF
.0860"	No. 44	none	4-36 NS
.0890"	No. 43	3/32"	4-40 NC
.0935"	No. 42	3/32"	4-48 NF
.0984"	2.5mm	none	3mm-0.60mm
.1015"	No. 38	none	1/8-40 NS
.1015"	No. 38	none	5-40 NC
.1040"	No. 37	none	5-44 NF
.1100"	No. 35	7/64"	6-32 NC
.1110"	No. 34	none	6-36 NS
.1130"	No. 33	none	6-40 NF
.1200"	No. 31	none	6-48 NS
.1338"	3.4mm	none	4mm-0.70mm
.1338"	3.4mm	none	4mm-0.75mm
.1360"	No. 29	none	8-32 NC
.1360"	No. 29	9/64"	8-36 NF
.1405"	No. 28	none	8-40 NS
.1470"	No. 26	none	3/16-24 NS
.1495"	No. 25	5/32"	10-24 NC
.1570"	No. 22	none	3/16-32 NS
.1590"	No. 21	5/32"	10-32 NF
.1653"	4.2mm	none	5mm-0.90mm
.1693"	4.3mm	none	5mm-0.80mm
.1770"	No. 16	11/64"	12-24 NC
.1820"	No. 14	3/16"	12-28 NF
.1850"	No. 13	none	12-32 NEF
.1935"	No. 10	none	14-20 NS
.2010"	No. 7	13/64"	1/4-20 NC
.2010"	No. 7	none	14-24 NS
.2047"	5.2mm	none	6mm-1.00mm
.2090"	No. 4	none	1/4-24 NS
.2130"	No. 3	7/32"	1/4-28 NF
.2188"	7/32"	7/32"	1/4-32 NEF
.2280"	No. 1	none	1/4-40 NS
.2401"	6.1mm	15/64"	7mm-1.00mm
.2570"	Ltr. F	17/64"	5/16-18 NC
.2716"	6.9mm	17/64"	8mm-1.25mm
.2720"	Ltr. I	none	5/16-24 NF
.2795"	7.1mm	none	8mm-1.00mm
.2812"	9/32"	9/32"	5/16-32 NEF
.3110"	7.9mm	none	9mm-1.25mm
.3125"	5/16"	5/16"	3/8-16 NC
.3189"	8.1mm	none	9mm-1.00mm
.3268"	8.3mm	none	9mm-0.75mm
.3320"	Ltr. Q	21/64"	3/8-24 NF
.3425"	8.7mm	none	10mm-1.50mm
.3503"	8.9mm	11/32"	10mm-1.25mm

DRILL THIS SIZE HOLE			TO TAP FOR THIS BOLT OR SCREW
DECIMAL INCHES	DRILL SIZE	NEAREST FRACTION	
.3583"	9.1mm	none	*10mm-1.00mm
.3680"	Ltr. U	23/64"	7/16"-14 NC
.3818"	9.7mm	none	11mm-1.50mm
.3906"	25/64"	25/64"	7/16-20 NF
.4133"	10.5mm	none	12mm-1.75mm
.4212"	10.7mm	27/64"	12mm-1.50mm
.4219"	27/64"	27/64"	1/2-13 NC
.4291"	10.9mm	27/64"	*12mm-1.25mm
.4531"	29/64"	29/64"	1/2-20 NF
.4531"	29/64"	29/64"	1/2-24 NS
.4803"	12.2mm	none	14mm-2.00mm
.4844"	31/64"	31/64"	9/16-12 NC
.4999"	12.7mm	none	14mm-1.50mm
.5039"	12.8mm	none	*14mm-1.25mm
.5156"	33/64"	33/64"	9/16-18 NF
.5312"	17/32"	17/32"	5/8-11 NC
.5590"	14.2mm	35/64"	16mm-2.00mm
.5781"	37/64"	37/64"	5/8-18 NF
.5787"	14.7mm	none	16mm-1.50mm
.5938"	19/32"	19/32"	11/16-11 NS
.6220"	15.8mm	39/64"	18mm-2.50mm
.6250"	5/8"	5/8"	11/16-16 NS
.6562"	21/32"	21/32"	3/4-10 NC
.6614"	16.8mm	none	*18mm-1.50mm
.6875"	11/16"	11/16"	3/4-16 NF
.7008"	17.8mm	11/16"	20mm-2.50mm
.7656"	49/64"	49/64"	7/8-9 NC
.8125"	13/16"	13/16"	7/8-14 NF
.8228"	20.9mm	none	22mm-1.50mm
.8281"	53/64"	53/64"	*7/8-18 NS
.8425"	21.4mm	53/64"	24mm-3.00mm
.8750"	7/8"	7/8"	1-8 NC
.8779"	22.3mm	none	24mm-2.00mm
.9219"	59/64"	59/64"	1-12 NF
.9375"	15/16"	15/16"	1-14 NS
.9844"	63/64"	63/64"	1-1/8 - 7 NC
1.0469"	1-3/64"	1-3/64"	1-1/8 - 12 NF
1.1094"	1-7/64"	1-7/64"	1-1/4 - 7 NC
1.1719"	1-11/64"	1-11/64"	1-1/4 - 12 NF
1.2188"	1-7/32"	1-7/32"	1-3/8 - 6 NC
1.2969"	1-19/64"	1-19/64"	1-3/8 - 12 NF
1.3468"	1-11/32"	1-11/32"	1-1/2 - 6 NC
1.4219"	1-27/64"	1-27/64"	1-1/2 - 12 NF

* Spark Plug Taps.

BI-METAL HOLE SAW CROSS REFERENCE

Size	ITM #	American Saw (Lenox)	Black & Decker	Dewalt	MagSaw	Makita	Milford Sandvik	Morse	Starrett
9/16"	275HW0011	30009-9L	21820	DW1820	624.0916	7140 01-A	44774	AV09	H0096
5/8"	275HW0012	30010-10L	21821	DW1821	624.1016	7140 02-A	44776	AV10	H0058
11/16"	275HW0013	30011-11L	21822	DW1822	624.1116	7140 03-A	44778	AV11	H1016
3/4"	275HW0014	30012-12L	21823	DW1823	624.1216	7140 04-A	44780	AV12	H0034
13/16"	275HW0015	30013-13L	21824	DW1824	624.1316	7140 05-A	44782	AV13	H1036
7/8"	275HW0016	30014-14L	21825	DW1825	624.1416	7140 06-A	44784	AV14	H0078
15/16"	275HW0017	30015-15L	21826	DW1826	624.1516	7140 07-A	44786	AV15	H1056
1"	275HW0018	30016-16L	21827	DW1827	624.1616	7140 08-A	44788	AV16	H0100
1-1/16"	275HW0185	30017-17L	21828	DW1828	624.1716	7140 09-A	44790	AV17	H0116
1-1/8"	275HW0019	30018-18L	21829	DW1829	624.1816	7140 10-A	44792	AV18	H0118
1-1/3/16"	275HW0020	30019-19L	21830	DW1830	624.1916	7140 11-A	44794	AV19	H0136
1-1/4"	275HW0021	30020-20L	21831	DW1831	624.2016	7140 12-A	44796	AV20	H0114
1-5/16"	275HW0022	30021-21L	21832	DW1832	624.2116	7140 13-A	44798	AV21	H0156
1-3/8"	275HW0023	30022-22L	21833	DW1833	624.2216	7140 14-A	44800	AV22	H0138
1-7/16"	275HW0123	30023-23L	21834	DW1834	624.2316	7140 15-A	44802	AV23	H0176
1-1/2"	275HW0024	30024-24L	21835	DW1835	624.2416	7140 16-A	44804	AV24	H0112
1-9/16"	275HW0124	30025-25L	21836	DW1836	624.2516	7140 17-A	44806	AV25	H0196
1-5/8"	275HW0025	30026-26L	21837	DW1837	624.2616	7140 18-A	44808	AV26	H0158
1-11/16"	275HW0125	30027-27L	21838	DW1838	624.2716	7140 19-A	44810	AV27	H1116
1-3/4"	275HW0026	30028-28L	21839	DW1839	624.2816	7140 20-A	44812	AV28	H0134
1-13/16"	275HW0126	30029-29L	21840	DW1840	624.2916	7140 21-A	44814	AV29	H1136
1-7/8"	275HW0027	30030-30L	21841	DW1841	624.3016	7140 22-A	44816	AV30	H0178
2"	275HW0028	30032-32L	21842	DW1842	624.3216	7140 23-A	44818	AV32	H0200
2-1/16"	275HW0128	30033-33L	21843	DW1843	624.3316	7140 24-A	44820	AV33	H0216
2-1/8"	275HW0029	30034-34L	21844	DW1844	624.3416	7140 25-A	44822	AV34	H0218
2-1/4"	275HW0030	30036-36L	21845	DW1845	624.3616	7140 26-A	44824	AV36	H0214
2-5/16"	275HW0031	30037-37L	21846	DW1846	624.3716	7140 27-A	44826	AV37	H0256
2-3/8"	275HW0032	30038-38L	21847	DW1847	624.3816	7140 28-A	44828	AV38	H0238
2-1/2"	275HW0033	30040-40L	21848	DW1848	624.4016	7140 29-A	44830	AV40	H0212
2-9/16"	275HW0034	30041-41L	21849	DW1849	624.4116	7140 30-A	44832	AV41	H0296
2-5/8"	275HW0134	30042-42L	21850	DW1850	624.4216	7140 31-A	44834	AV42	H0258
2-3/4"	275HW0135	30044-44L	21851	DW1851	624.4416	7140 32-A	44836	AV44	H0234
2-7/8"	275HW0136	30046-46L	21852	DW1852	624.4616	7140 33-A	44838	AV46	H0278
3"	275HW0035	30048-48L	21853	DW1853	624.4816	7140 34-A	44840	AV48	H0300
3-1/8"	275HW0137	30050-50L	21854	DW1854	624.5016	7140 35-A	44842	AV50	H0318
3-1/4"	275HW0138	30052-52L	21855	DW1855	624.5216	7140 36-A	44844	AV52	H0314
3-3/8"	275HW0139	30054-54L	21856	DW1856	624.5416	7140 37-A	44846	AV54	H0338
3-1/2"	275HW0036	30056-56L	21857	DW1857	624.5616	7140 38-A	44848	AV56	H0312
3-5/8"	275HW0140	30058-58L	21858	DW1858	624.5816	7140 39-A	44850	AV58	H0358
3-3/4"	275HW0141	30060-60L	21859	DW1859	624.6016	7140 40-A	44852	AV60	H0334
3-7/8"	275HW0142	30062-62L	21860	DW1860	624.6216	7140 41-A	44854	AV62	H0378
4"	275HW0037	30064-64L	21861	DW1861	624.6416	7140 42-A	44856	AV64	H0400
4-1/8"	275HW0143	30066-66L	21862	DW1862	624.6616	7140 43-A	44858	AV66	H0418-
1/4"	275HW0144	30068-68L	21863	DW1863	624.6816	7140 44-A	44860	AV68	H0414
4-3/8"	N/A	30070-70L	21864	DW1864	624.7016	7140 45-A	44861	AV70	H0138
4-1/2"	275HW0038	30070-72L	21865	DW1865	624.7216	7140 46-A	44862	AV72	H0412
4-3/4"	275HW0145	30078-78L	21866	DW1866	6247616	7140 47-A	44864	AV76	H0434
5"	275HW0039	30080-80L	21867	DW1867	624.8016	7140 48-A	44866	AV80	H0500
5-1/2"	275HW0040	30088-88L	21869	DW1868	624.8816	7140 49-A	44868	AV88	H0512
5-3/4"	275HW0146	N/A	N/A	N/A	624.9216	N/A	N/A	AV92	N/A
6"	275HW0041	30096-96L	21871	DW1871	624.9616	7140 50-A	44470	AV96	H0600

ARBOR CROSS REFERENCE (LENOX)

ITM #	American Saw (Lenox)	Description
276AR0002	30001-1L	9/16" TO 1-3/16" ARBOR 7/16
276AR0003	30002-2L	1-1/4" TO 6" ARBOR 7/16" HEX
N/A	30003-3L	
276AR0001	30004-4L	9/16" TO 1-3/16" ARBOR 1/4"
N/A	30005-5L	
276AR0035	30006-6L	1-1/4" TO 6" ARBOR 3/8" HEX

HSS STEP-DRILL CROSS REFERENCE

ITM #	Greenlee	Klein	Lenox	Mag Bit	Magna	Milwaukee	M.K. Morse	Uni-Bit	VA
274MC0001	34401	59001	VB1	851.0500A-01	44685	48-78-9100	ESD01	1	13370
274MC0002	36402	59005	VB4	851.0500B-02	44694	N/A	ESD02	2	N/A
274MC0003	N/A	59003	VB3	851.0750-03	44687	48-89-9105	ESD04	3	13372
274MC0004	34403	59014	N/A	851.0875-04	44692	48-89-9130	ESD03	4	N/A
274MC0005	N/A	N/A	N/A	851.1125-05	N/A	N/A	N/A	N/A	N/A
274MC0006	N/A	59004	N/A	851.1375-06	N/A	N/A	N/A	N/A	N/A
274MC0007	N/A	N/A	N/A	851.0750B-09	N/A	N/A	N/A	N/A	N/A
274MC0008	36413	59011	VB11	851.1125B-11	44691	48-89-9135	ESD05	N/A	N/A
274MC0009	46414	N/A	VB12	851.1375B-12	N/A	N/A	N/A	N/A	N/A
274MC0010	34411	59008	VB7	850.0875-07	44688	48-89-9115	ESD10	11	13373

SHORT SHIP AUGER CROSS REFERENCE

SIZE	ITM #	OAL	Mag-Bit Hvy Duty	OAL	Mag-Bit Std Duty	OAL	Lenox	OAL	Milwaukee	OAL	GB	OAL
1/2"	302SL3264	8"	357DLX.0816	8"	715-0816	6"	N/A		N/A		N/A	
9/16"	302SL3664	8"	357DLX.0916	8"	715-0916	6"	N/A		N/A		N/A	
5/8"	302SL4064	8"	357DLX.1016	8"	715-1016	6"	31030-07A-1016	7-1/2"	N/A		SA-10S	7-1/2"
11/16"	302SL4464	8"	357DLX.1116	8"	715-1116	6"	31030-07A-1116	7-1/2"	48-13-0683	6"	SA-11S	7-1/2"
3/4"	302SL4864	8"	357DLX.1216	8"	715-1216	6"	31030-07A-1216	7-1/2"	48-13-0753	6"	SA-12S	7-1/2"
13/16"	302SL5264	8"	357DLX.1316	8"	715-1316	6"	31030-07A-1316	7-1/2"	48-13-0813	6"	SA-13S	7-1/2"
7/8"	302SL5664	8"	357DLX.1416	8"	715-1416	6"	31030-07A-1416	7-1/2"	48-13-0873	6"	SA-14S	7-1/2"
15/16"	302SL6064	8"	357DLX.1516	8"	715-1516	6"	31030-07A-1516	7-1/2"	48-13-0933	6"	N/A	
1"	302SL6464	8"	357DLX.1616	8"	715-1616	6"	31030-07A-1616	7-1/2"	48-13-1003	6"	SA-16S	7-1/2"
1-1/16"	N/A		N/A		N/A		31030-07A-1716	7-1/2"	48-13-1063	6"	N/A	
1-1/8"	302SL7264	8"	357DLX.1816	8"	715-1816	6"	31030-07A-1816	7-1/2"	48-13-1123	6"	SA-18S	7-1/2"
1-1/4"	302SL8064	8"	357DLX.2016	8"	715-2016	6"	31030-07A-2016	7-1/2"	48-13-1253	6"	SA-20S	7-1/2"
1-3/8"	302SL8864	8"	357DLX.2216	8"	715-2216	6"	31030-07A-2216	7-1/2"	48-13-1373	6"	N/A	
1-1/2"	302SL9664	8"	357DLX.2416	8"	715-2416	6"	31030-07A-2416	7-1/2"	48-13-1503	6"	N/A	

SIZE	ITM #	OAL	IRWIN	OAL	KLEIN	OAL	Primark	OAL
1/2"	302SL3264	8"	N/A		N/A		47505	8"
9/16"	302SL3664	8"	N/A		N/A		47506	8"
5/8"	302SL4064	8"	42410	7-1/2"	N/A		47507	8"
11/16"	302SL4464	8"	42411	7-1/2"	53401	6"	47508	8"
3/4"	302SL4864	8"	42412	7-1/2"	53402/53426	6"/7-3/4"	47509	8"
13/16"	302SL5264	8"	42413	7-1/2"	53403	6"	47510	8"
7/8"	302SL5664	8"	42414	7-1/2"	53404/53428	6"/7-3/4"	47511	8"
15/16"	302SL6064	8"	N/A		53405	6"	46512	8"
1"	302SL6464	8"	42416	7-1/2"	53406/53429	6"/7-3/4"	47513	8"
1-1/16"	N/A		N/A		53407	6"	N/A	
1-1/8"	302SL7264	8"	42418	7-1/2"	53408/53530	6"/7-3/4"	47514	8"
1-1/4"	302SL8064	8"	42420	7-1/2"	53409/53431	6"/7-3/4"	47515	8"
1-3/8"	302SL8864	8"	N/A		53410	6"	47516	8"
1-1/2"	302SL9664	8"	N/A		53411	6"	47517	8"

LONG SHIP AUGER CROSS REFERENCE

SIZE	ITM #	OAL	Mag-Bit Hvy Duty	OAL	Mag-Bit Std Duty	OAL	Lenox	OAL	Greenlee	OAL	Milwaukee	OAL	GB	OAL
1/4"	N/A		303DLX.0416	18"	N/A		N/A		N/A		N/A		N/A	
5/16"	N/A		303DLX.0516	18"	N/A		N/A		N/A		N/A		N/A	
3/8"	303SL2464	18"	303DLX.0616	18"	735-0616	17"	N/A		N/A		N/A		N/A	
7/16"	303SL2864	18"	303DLX.0716	18"	735-0716	17"	N/A		N/A		N/A		N/A	
1/2"	303SL3264	18"	303DLX.0816	18"	735-0816	17"	N/A		66PT-1/2	18"	N/A		SA-08	17"
9/16"	303SL3664	18"	303DLX.0916	18"	735-0916	17"	31009-008-0916	18"	N/A		48-13-5560	18"	N/A	
5/8"	303SL4064	18"	303DLX.1016	18"	735-1016	17"	31010-008-1016	18"	66PT-5/8	18"	48-13-5520	18"	SA-10	17"
11/16"	303SL4464	18"	303DLX.1116	18"	735-1116	17"	31011-008-1116	18"	66PT-11/16	18"	48-13-5680	18"	SA-11	17"
3/4"	303SL4864	18"	303DLX.1216	18"	735-1216	17"	31012-008-1216	18"	66PT-3/4	18"	48-13-5750	18"	SA-12	17"
13/16"	303SL5264	18"	303DLX.1316	18"	735-1316	17"	31013-008-1316	18"	66PT-1316	18"	48-13-5810	18"	SA-13	17"
7/8"	303SL5664	18"	303DLX.1416	18"	735-1416	17"	31014-008-1416	18"	66PT-7/8	18"	48-13-5870	18"	SA-14	17"
15/16"	303SL6064	18"	303DLX.1516	18"	735-1516	17"	31015-008-1516	18"	66PT-15/16	18"	48-13-5930	18"	SA-15	17"
1"	303SL6464	18"	303DLX.1616	18"	735-1616	17"	31016-008-1616	18"	66PT-1	18"	48-13-6000	18"	SA-16	17"
1-1/16"	N/A		N/A		735-1716	17"	31017-008-1716	18"	N/A		48-13-6010	18"	N/A	
1-1/8"	303SL7264	18"	303DLX.1816	18"	735-1816	17"	31018-008-1816	18"	66PT-1-1/8	18"	48-13-6120	18"	SA-18	17"
1-1/4"	303SL8064	18"	303DLX.2016	18"	735-2016	17"	31020-008-2016	18"	66PT-1-1/4	18"	48-13-6250	18"	SA-20	17"
1-3/8"	303SL8864	18"	303DLX.2216	18"	735-2216	17"	31022-008-2216	18"	N/A		48-13-6370	18"	N/A	
1-1/2"	303SL9664	18"	303DLX.2416	18"	735-2416	17"	31024-008-2416	18"	N/A		48-13-6500	18"	N/A	

SIZE	ITM #	OAL	IRWIN	OAL	KLEIN	OAL	Primark	OAL
1/4"	N/A	18"	N/A		N/A		N/A	
5/16"	N/A	18"	N/A		N/A		N/A	
3/8"	303SL2464	18"	47406	17"	N/A		47519	18"
7/16"	303SL2864	18"	47407	17"	N/A		47520	18"
1/2"	303SL3264	18"	47408	17"	N/A		47521	18"
9/16"	303SL3664	18"	47409	17"	53434	18"	47522	18"
5/8"	303SL4064	18"	47410	17"	53435	18"	47523	18"
11/16"	303SL4464	18"	47411	17"	53436	18"	47524	18"
3/4"	303SL4864	18"	47412	17"	53437	18"	47525	18"
13/16"	303SL5264	18"	47413	17"	53438	18"	47526	18"
7/8"	303SL5664	18"	47414	17"	53439	18"	47527	18"
15/16"	303SL6064	18"	47415	17"	53440	18"	47528	18"
1"	303SL6464	18"	47416	17"	53441	18"	47529	18"
1-1/16"	N/A		47417	17"	53442	18"	47530	18"
1-1/8"	303SL7264	18"	47418	17"	53443	18"	47531	18"
1-3/16"	N/A		N/A		N/A		47532	18"
1-1/4"	303SL8064	18"	47420	17"	53444	18"	47533	18"
1-5/16"	N/A		N/A		N/A		47534	18"
1-3/8"	303SL8864	18"	7422	17"	53445	18"	47535	18"
1-1/2"	303SL9664	18"	47424	17"	53446	18"	47536	18"